

TECHNICAL MANUAL

UNIT MAINTENANCE MANUAL

FOR
CARRIER, PERSONNEL, FULL TRACKED, ARMORED M113A3
2350-01-219-7577 (EIC AEY)

CARRIER, COMMAND POST, LIGHT TRACKED M577A3
2350-01-369-6085 (EIC AE7)

CARRIER, SMOKE GENERATOR, FULL TRACKED M1059A3
2350-01-369-6083 (EIC AFA)

CARRIER, MORTAR, 120-MM M121, SELF-PROPELLED M1064A3
2350-01-369-6082 (EIC AE8)

CARRIER, STANDARDIZED INTEGRATED COMMAND POST SYSTEM
(SICPS) M1068A3
2350-01-369-6086 (EIC AFC)

CARRIER, MECHANIZED SMOKE OBSCURANT M58
2350-01-418-6654 (EIC 5CG)

SUPERSEDURE NOTICE — This manual supersedes TM 9-2350-277-20 dated 24 July 1994, including all changes.

DISTRIBUTION STATEMENT A — Approved for public release; distribution is unlimited.

HEADQUARTERS, DEPARTMENT OF THE ARMY

January 2001

**TECHNICAL MANUAL
UNIT MAINTENANCE MANUAL
FOR**

**CARRIER, PERSONNEL, FULL TRACKED, ARMORED M113A3
2350-01-219-7577 (EIC AEY)**

**CARRIER, COMMAND POST, LIGHT TRACKED M577A3
2350-01-369-6085 (EIC AE7)**

**CARRIER, SMOKE GENERATOR, FULL TRACKED M1059A3
2350-01-369-6083 (EIC AFA)**

**CARRIER, MORTAR, 120-MM M121, SELF-PROPELLED M1064A3
2350-01-369-6082 (EIC AE8)**

**CARRIER, STANDARDIZED INTEGRATED COMMAND POST SYSTEM (SICPS) M1068A3
2350-01-369-6086 (EIC AFC)**

**CARRIER, MECHANIZED SMOKE OBSCURANT M58
2350-01-418-6654 (EIC 5CG)**

DISTRIBUTION STATEMENT A – Approved for public release; distribution is unlimited.

TM 9-2350-277-20-2, 2 January 2001 is updated as follows:

1. File this change sheet in front of the publication for reference purposes.
2. New or updated text is indicated by a vertical bar in the outer margin of the page.
3. Revised illustrations are indicated by a miniature pointing hand adjacent to the updated area.
4. Remove old pages/Work Packages and insert new pages/Work Packages as indicated below.

Remove Pages/Work Packages

Title
A/B
i-xxx
Chapter 3 WP Index
WP 0154 00
WP 0155 00
Chapter 4 WP Index
WP 0156 00
WP 0159 00
WP 0160 00
Chapter 5 WP Index
WP 0179 00
WP 0192 00
WP 0195 00
WP 0202 00
WP 0203 00
Chapter 7 WP Index
WP 0231 00
WP 0231 01
WP 0249 00
WP 0249 01
WP 0250 00
None
WP 0251 00
WP 0251 01
Index
Cover

Insert Pages/Work Packages

Title
A/B
i-v/vi blank
Chapter 3 WP Index
WP 0154 00
WP 0155 00
Chapter 4 WP Index
WP 0156 00
WP 0159 00
None
Chapter 5 WP Index
WP 0179 00
WP 0192 00
WP 0195 00
WP 0202 00
WP 0203 00
Chapter 7 WP Index
WP 0231 00
WP 0231 01
WP 0249 00
WP 0249 01
WP 0250 00
WP 0250 01
WP 0251 00
WP 0251 01
Index
Cover

By Order of the Secretary of the Army:

PETER J. SCHOOMAKER
General, United States Army
Chief of Staff

Official:

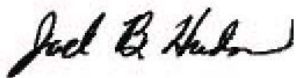

JOEL B. HUDSON
Administrative Assistant to the
Secretary of the Army
0327304

DISTRIBUTION:

To be distributed in accordance with the initial distribution number (IDN) 371205 requirements for TM 9-2350-277-20-2.

**TECHNICAL MANUAL
UNIT MAINTENANCE MANUAL
FOR**

**CARRIER, PERSONNEL, FULL TRACKED, ARMORED M113A3
2350-01-219-7577 (EIC AEY)**

**CARRIER, COMMAND POST, LIGHT TRACKED M577A3
2350-01-369-6085 (EIC AE7)**

**CARRIER, ANTI-TANK (TOW), FULL TRACKED, ARMORED M901A3
2350-01-369-7253 (EIC AFD)**

**CARRIER, FIRE SUPPORT PERSONNEL, FULL TRACKED, ARMORED M981A3
2350-01-369-6079 (EIC AFB)**

**CARRIER, SMOKE GENERATOR, FULL TRACKED M1059A3
2350-01-369-6083 (EIC AFA)**

**CARRIER, MORTAR, 120-MM M121, SELF-PROPELLED M1064A3
2350-01-369-6082 (EIC AE8)**

**CARRIER, STANDARDIZED INTEGRATED COMMAND POST SYSTEM (SICPS) M1068A3
2350-01-369-6086 (EIC AFC)**

**CARRIER, MECHANIZED SMOKE OBSCURANT M58
2350-01-418-6654 (EIC 5CG)**

DISTRIBUTION STATEMENT A – Approved for public release; distribution is unlimited.

TM 9-2350-277-20-2, 2 January 2001 is updated as follows:

1. File this change sheet in front of the publication for reference purposes.
2. New or updated text is indicated by a vertical bar in the outer margin of the page.
3. Revised illustrations are indicated by a miniature pointing hand adjacent to the updated area.
4. Remove old pages/Work Packages and insert new pages/Work Packages as indicated below.

Remove Pages/Work Packages

A/B
i-xxix/xxx blank
WP 0155 00
WP 0160 00
WP 0168 00
WP 0176 00
WP 0182 00
WP 0184 00
WP 0185 00
WP 0194 00
WP 0197 00
WP 0220 00
WP 0227 00
WP 0239 00
WP 0240 00
Index

Insert Pages/Work Packages

A/B blank
i-xxx
WP 0155 00
WP 0160 00
WP 0168 00
WP 0176 00
WP 0182 00
WP 0184 00
WP 0185 00
WP 0194 00
WP 0197 00
WP 0220 00
WP 0227 00
WP 0239 00
WP 0240 00
Index

Official:



JOEL B. HUDSON

*Administrative Assistant to the
Secretary of the Army*

0133206

PETER J. SCHOOMAKER
*General, United States Army
Chief of Staff*

DISTRIBUTION:

To be distributed in accordance with the initial distribution number (IDN) 371205 requirements for TM 9-2350-277-20-2.

INSERT LATEST UPDATED PAGES/WORK PACKAGES. DESTROY SUPERSEDED DATA.

LIST OF EFFECTIVE PAGES/WORK PACKAGES

Note: Updates to all portions of this TM are indicated by a vertical bar in the outer margin of the page.

Dates of issue for original and updated pages/work packages are:

- Original 0 (2 January 2001)
- Change 1 (5 September 2003)
- Change 2 (2 October 2003)

TOTAL NUMBER OF PAGES FOR FRONT AND REAR MATTER IS 130 AND TOTAL NUMBER OF WORK PACKAGES IS 98 CONSISTING OF THE FOLLOWING:

Page/WP No.	*Change No.	Page/WP No.	*Change No.	Page/WP No.	*Change No.
Title	2	WP 0231 01 (Added)	2		
A – B blank	2	WP 0232 00-0238 00	0		
i-vi blank	2	WP 0239 00	1		
vii-xxx (Deleted)	2	WP 0240 00	1		
Chapter 3 WP Index	2	WP 0241 00-0248 00	0		
WP 0154 00-0155 00	2	WP 0249 00	2		
Chapter 4 WP Index	2	WP 0249 01 (Added)	2		
WP 0156 00	2	WP 0250 00	2		
WP 0157 00-0158 00	0	WP 0250 01 (Added)	2		
WP 0159 00	2	WP 0251 00	2		
WP 0160 00 (Deleted)	2	WP 0251 01 (Added)	2		
WP 0161 00-0165 00	0	Index 1 – Index 103	2		
Chapter 5 WP Index	2	DA2028/Back	0		
WP 0166 00-0167 00	0	Authentication Page	0		
WP 0168 00	1	Metric Chart	0		
WP 0169 00-0175 00	0	Back Cover	0		
WP 0176 00	1				
WP 0177 00-0178 00	0				
WP 0179 00	2				
WP 0180 00-0181 00	0				
WP 0182 00	1				
WP 0183 00	0				
WP 0184 00	1				
WP 0185 00	1				
WP 0186 00-0191 00	0				
WP 0192 00	2				
WP 0193 00	0				
WP 0194 00	1				
WP 0195 00	2				
WP 0196 00	0				
WP 0197 00	1				
WP 0198 00-0201 00	0				
WP 0202 00-0203 00	2				
WP 0204 00-0219 00	0				
WP 0220 00	1				
Chapter 6 WP Index	2				
WP 0221 00-0226 00	0				
Chapter 7 WP Index	2				
WP 0227 00	1				
WP 0228 00-0230 00	0				
WP 0231 00	2				

*Zero in this column indicates an original page

Change 2

HEADQUARTERS
DEPARTMENT OF THE ARMY
WASHINGTON, D.C., 02 January 2001

TECHNICAL MANUAL

UNIT MAINTENANCE MANUAL

CARRIER, PERSONNEL, FULL TRACKED, ARMORED M113A3
NSN 2350-01-219-7577
(EIC AEY)

CARRIER, COMMAND POST, LIGHT TRACKED M577A3
NSN 2350-01-369-6085
(EIC AE7)

CARRIER, SMOKE GENERATOR, FULL TRACKED M1059A3
NSN 2350-01-369-6083
(EIC AFA)

CARRIER, MORTAR, 120-MM M121, SELF-PROPELLED M1064A3
NSN 2350-01-369-6082
(EIC AE8)

CARRIER, STANDARDIZED INTEGRATED COMMAND POST SYSTEM (SICPS) M1068A3
NSN 2350-01-369-6086
(EIC AFC)

CARRIER, MECHANIZED SMOKE OBSCURANT M58
NSN 2350-01-418-6654
(EIC 5CG)

REPORTING ERRORS AND RECOMMENDING IMPROVEMENTS

You can help improve this publication. If you find any mistakes or if you know of a way to improve the procedures, please let us know. Submit your DA Form 2028-2 (Recommended Changes to Equipment Technical Publications), through the Internet, on the Army Electronic Product Support (AEPS) website. The internet address is <http://aeprs.ria.army.mil>. If you need a password, scroll down and click on "ACCESS REQUEST FORM". The DA 2028 is located in the ONLINE FORMS PROCESSING section of the AEPS. Fill out the form and click on SUBMIT. Using this form on the AEPS will enable us to respond quicker to your comments and better manage the DA Form 2028 program. You may also mail, fax, or E-mail your letter, DA Form 2028 or DA Form 2028-2 direct to: Technical Publication Information Office, TACOM-RI, 1 Rock Island Arsenal, Rock Island, IL 61299-7630. The email address is TACOM-TECH-PUBS@ria.army.mil. The fax number is DSN 793-0726 or Commercial (309)782-0726.

SUPERSEDURE NOTICE — This manual supersedes TM 9-2350-277-20 dated 24 July 1994, including all changes.

DISTRIBUTION STATEMENT A — Approved for public release; distribution is unlimited.

TABLE OF CONTENTS

WP Sequence No.

Volume 2

CHAPTER 3— UNIT MAINTENANCE INSTRUCTIONS FOR CARRIER

SERVICE UPON RECEIPT	0154 00
PREVENTIVE MAINTENANCE CHECKS AND SERVICES (PMCS), INCLUDING LUBRICATION INSTRUCTIONS.....	0155 00

CHAPTER 4— UNIT MAINTENANCE INSTRUCTIONS FOR ENGINE

REMOVE/INSTALL POWER PLANT ASSEMBLY	0156 00
BLOCK POWER PLANT.....	0157 00
REPLACE ENGINE MOUNTS	0158 00
REPLACE LEFT AND RIGHT AIR BOX DRAIN CHECK VALVE AND TUBES.....	0159 00
DELETED.....	0160 00
REPLACE ENGINE LIFTING BRACKET	0161 00
REPLACE ENGINE OIL FILLER CAP	0162 00
REPLACE ENGINE OIL SAMPLING VALVE AND HOSE.....	0163 00
REPLACE OIL GAUGE ROD AND TUBE	0164 00
REPLACE OIL FILTER ELEMENT	0165 00

CHAPTER 5 —UNIT MAINTENANCE INSTRUCTIONS FOR FUEL SYSTEM

REPLACE ENGINE FUEL PUMP.....	0166 00
SERVICE AIR CLEANER FILTER ELEMENT	0167 00
REPLACE AIR CLEANER AND ELBOW	0168 00
REPAIR AIR CLEANER ASSEMBLY	0169 00
REPAIR AIR CLEANER RETAINER.....	0170 00
REPLACE AIR CLEANER RESTRICTION INDICATOR	0171 00
REPLACE AIR CLEANER RESTRICTION INDICATOR HOSE.....	0172 00
REMOVE/INSTALL AIR INTAKE ELBOW	0173 00
REPLACE GRILL AIR INTAKE ELBOW AND HOSE.....	0174 00
REPLACE EXHAUST EVACUATOR VALVE AND CONNECTOR.....	0175 00
CLEAN FUEL CAP VENT AND FILTER SCREEN.....	0176 00
DRAIN TANKS (ALL EXCEPT M577A3 AND M1068A3).....	0177 00
DRAIN FUEL TANKS (M577A3 AND M1068A3 ONLY).....	0178 00

TABLE OF CONTENTS (cont)

	<u>WP Sequence No.</u>
REPLACE EXTERNAL FUEL TANKS (ALL EXCEPT M577A3 AND M1068A3).....	0179 00
REPLACE FUEL TANKS (M577A3 AND M1068A3 ONLY).....	0180 00
TEMPORARY FUEL TANK REPAIR (M577A3 AND M1068A3 ONLY).....	0181 00
REPLACE FUEL TANK FILLER COVER AND LOCK (ALL EXCEPT M577A3 AND M1068A3)	0182 00
REPLACE FUEL TANK FILLER COVER AND LOCK (M577A3 AND M1068A3 ONLY).....	0183 00
REPLACE FILLER CAP AND STRAINER PARTS (ALL EXCEPT M577A3 AND M1068A3)	0184 00
REPLACE FILLER CAP AND STRAINER PARTS (M577A3 AND M1068A3 ONLY).....	0185 00
REPLACE FUEL FILLER AND STRAINER PARTS (M577A3 AND M1068A3 ONLY)	0186 00
REPLACE FUEL TANK ACCESS COVERS AND DRAIN PLUGS (ALL EXCEPT M577A3 AND M0187 00	
REPLACE FUEL TANK ACCESS COVERS (M577A3 AND M1068A3 ONLY).....	0188 00
REPLACE FUEL TANK FILLER FLANGE (M577A3 AND M1068A3 ONLY).....	0189 00
REPLACE FUEL QUANTITY TRANSMITTER (ALL EXCEPT M577A3 AND M1068A3)	0190 00
REPLACE FUEL QUANTITY TRANSMITTER (M577A3 AND M1068A3 ONLY)	0191 00
REPLACE FUEL SUPPLY HOSES, TUBES, AND FITTINGS (M113A3, M1059A3, AND M58 ONLY)	0192 00
REPLACE FUEL SUPPLY HOSES, TUBES AND FITTINGS (M577A3 AND M1068A3 ONLY)	0193 00
REPLACE FUEL SUPPLY HOSES, TUBES, AND FITTINGS (M1064A3 ONLY)	0194 00
REPLACE FUEL RETURN HOSES, TUBES, AND FITTINGS (M113A3, M1059A3, AND M58 ONLY)	0195 00
REPLACE FUEL RETURN HOSES, TUBES, AND FITTINGS (M577A3 AND M1068A3 ONLY)	0196 00
REPLACE FUEL RETURN HOSES, TUBES, AND FITTINGS (M1064A3 ONLY)	0197 00
REPLACE FUEL VENT HOSES, TUBES, AND FITTINGS (M577A3 AND M1068A3 ONLY).....	0198 00
REPLACE FUEL VALVE MOUNTING BLOCKS (ALL EXCEPT M577A3 AND M1068A3)	0199 00
REPLACE ENGINE FUEL SUPPLY HOSE.....	0200 00
REPLACE ENGINE FUEL RETURN HOSE.....	0201 00
REPLACE PRIMARY AND SECONDARY FUEL FILTER ELEMENTS.....	0202 00
REPLACE PRIMARY AND SECONDARY FUEL FILTERS AND BRACKET	0203 00
REPLACE AIR BOX HEATER IGNITION WIRE.....	0204 00
REPLACE AIR BOX HEATER WIRING HARNESS.....	0205 00
REPLACE AIR BOX HEATER LOWER FUEL LINE.....	0206 00

TABLE OF CONTENTS (cont)

WP Sequence No.

REPLACE AIR HEATER IGNITER.....	0207 00
REPLACE AIR BOX IGNITION COIL.....	0208 00
REPLACE GLOW PLUG HARNESS AND GLOW PLUGS	0209 00
REPLACE GLOW PLUG CONTROLLER	0210 00
REPLACE GLOW PLUG POWER HARNESS.....	0211 00
REPLACE GLOW PLUG CONTROLLER MOUNTING BRACKET	0212 00
ADJUST THROTTLE VALVE (TV) MODULATOR.....	0213 00
ADJUST ACCELERATOR LINKAGE	0214 00
REPLACE LOWER ACCELERATOR PEDAL	0215 00
REPLACE UPPER ACCELERATOR PEDAL ASSEMBLY.....	0216 00
REPLACE FUEL CONTROL SHAFT AND LINKAGE	0217 00
REPLACE THROTTLE VALVE (TV) MODULATOR AND LEVER	0218 00
REPLACE HAND THROTTLE CONTROL CABLE ASSEMBLY	0219 00
REPLACE FUEL CUTOFF CONTROL CABLE ASSEMBLY	0220 00

CHAPTER 6— UNIT MAINTENANCE INSTRUCTIONS FOR EXHAUST SYSTEM

REPLACE ENGINE EXHAUST ELBOWS AND DOUBLE FLEX JOINT.....	0221 00
REPAIR DOUBLE FLEX EXHAUST JOINT.....	0222 00
REPLACE MUFFLER EXTENSION AND CAP	0223 00
REPLACE EXHAUST MUFFLER AND BRACKET	0224 00
REPLACE ENGINE LEFT/RIGHT EXHAUST ELBOWS.....	0225 00
REPLACE LEFT/RIGHT TURBO EXHAUST PIPE HEAT SHIELD	0226 00

CHAPTER 7— UNIT MAINTENANCE INSTRUCTIONS FOR COOLING SYSTEM

DRAIN AND FILL COOLING SYSTEM.....	0227 00
CLEAN RADIATOR.....	0228 00
REPLACE RADIATOR AND PARTS.....	0229 00
REPLACE AUXILIARY TANK.....	0230 00
REPLACE THERMOSTATIC FAN SPEED SWITCH (OLD CONFIGURATION)	0231 00
REPLACE VARIABLE SPEED FAN DRIVE AND OVERRIDE SWITCH (NEW CONFIGURATION)	0231 01
REPLACE UPPER COOLANT HOSE AND TUBE	0232 00
REPLACE RADIATOR OUTLET TUBE AND HOSES	0233 00
REPLACE BALANCE HOSE.....	0234 00
REPLACE DRAIN COCK AND HOSE	0235 00
REPLACE COOLANT AIR SEPARATOR.....	0236 00
REPLACE THERMOSTAT/COVER.....	0237 00

TABLE OF CONTENTS (cont)

	<u>WP Sequence No.</u>
REPLACE THERMOSTAT TUBE/HOSES	0238 00
ADJUST COOLANT PUMP BELTS	0239 00
REPLACE COOLANT PUMP IDLER PULLEY/BELTS	0240 00
REPLACE ENGINE COOLANT PUMP	0241 00
ADJUST VENTILATING FAN DRIVE BELT	0242 00
REPLACE VENTILATING FAN DRIVE BELT	0243 00
REPLACE VENTILATING FAN DRIVE PULLEY	0244 00
REPLACE FLAT PULLEYS AND BEARINGS	0245 00
REPLACE IDLER ARM AND SPRING TENSIONER	0246 00
REPLACE VENTILATING FAN ASSEMBLY	0247 00
REPLACE FAN DRIVE SHAFT AND BEARING HOUSING	0248 00
REPLACE FAN AND GENERATOR VARIABLE SPEED FAN DRIVE (OLD CONFIGURATION)	0249 00
REPLACE VARIABLE SPEED FAN DRIVE ASSEMBLY (NEW CONFIGURATION).....	0249 01
REPLACE HOSE FROM THERMOSTAT TO VARIABLE SPEED FAN DRIVE (OLD CONFIGURATION)	0250 00
REPLACE VARIABLE SPEED DRIVE CONTROLLER (NEW CONFIGURATION).....	0250 01
REPLACE TRANSMISSION OIL SUPPLY AND RETURN HOSES (OLD CONFIGURATION) ..	0251 00
REPLACE HOSE FROM VARIABLE SPEED FAN DRIVE OVERRIDE SWITCH TO VSFD DRIVE (NEW CONFIGURATION).....	0251 01

CHAPTER 3
UNIT MAINTENANCE INSTRUCTIONS
FOR CARRIER

WORK PACKAGE INDEX

<u>Title</u>	<u>Sequence No.</u>
SERVICE UPON RECEIPT.....	0154 00
PREVENTIVE MAINTENANCE CHECKS AND SERVICES (PMCS), INCLUDING LUBRICATION INSTRUCTIONS.....	0155 00

SERVICE UPON RECEIPT

0154 00

THIS WORK PACKAGE COVERS:

This section contains information on how to check the M58, M113A3, M577A3, M1059A3, M1064A3, and M1068A3 carriers when received.

INITIAL SETUP:Maintenance LevelUnit

PRELIMINARY CHECKS AND ADJUSTMENTS**CHECKING UNPACKED EQUIPMENT**

1. Do the following steps to check carriers and parts upon receipt:
 - a. Inspect the equipment for possible damage incurred during shipment. If the equipment has been damaged, report the damage on DD Form 6, Packaging Improvement Report.
 - b. Check equipment against the packing slip and the BII in TM 9-2350-277-10 (All Carriers), to see if shipment is complete. Report all differences using the procedure given in DA Pamphlet 738-750.
 - c. Check to see whether the equipment has been modified. See DA Form 2408-9, Transfer, Gain, and Loss Report.

END OF TASK

**PREVENTIVE MAINTENANCE CHECKS AND SERVICES (PMCS),
INCLUDING LUBRICATION INSTRUCTIONS**

0155 00

THIS WORK PACKAGE COVERS:

Semi-Annual (Table 18, page 0155 00-33).
Annual (Table 19, page 0155 00-174).

INITIAL SETUP:

<u>Maintenance Level</u>	<u>References</u>
<u>Unit</u>	See your -10
<u>Tools and Special Tools</u>	FM 9-207
Adapter (WP 0926 00, Item 4)	TM 9-214
Socket Set (WP 0926 00, Item 71)	TB 43-0211
Socket Set (WP 0926 00, Item 72)	TM 43-0319
Torque Wrench (WP 0926 00, Item 79)	TM-3-6680-316-10
Torque Wrench (WP 0926 00, Item 80)	TM 3-6665-224-12
Torque Wrench (WP 0926 00, Item 81)	TM 9-6100-200-14
Torque Wrench (WP 0926 00, Item 82)	TM 9-2350-277-24P
Torque Wrench (WP 0926 00, Item 85)	TM 9-2450-205-24&P
<u>Materials/Parts</u>	TM 3-4240-276-30
Automotive grease (WP 0928 00, Item 12)	TM 3-4240-276-30P
Cleaning compound (WP 0928 00, Item 19)	TM 10-5410-229-13&P
General purpose detergent (WP 0928 00, Item 35)	
Sealing tape (WP 0928 00, Item 39)	
<u>Personnel Required</u>	<u>Equipment Condition</u>
Unit Mechanic	Engine stopped (see your -10)

SCOPE

This section details preventive maintenance checks and services (PMCS) and lubrication procedures required for the M113A3 FOV Carriers at the unit maintenance level. For crew level PMCS, see your -10.

MAINTENANCE FORMS AND RECORDS

The forms and records you fill out have many uses. They are a permanent record of the service, repairs, and changes made to your vehicle. They also tell you whether faults have been repaired. For information on forms and records, see DA Pamphlet 738-750.

WARNINGS AND CAUTIONS

Always observe the WARNINGS and CAUTIONS appearing in the PMCS tables BEFORE, DURING, and AFTER you operate the equipment. The WARNINGS and CAUTIONS appear before certain procedures. You must observe these WARNINGS and CAUTIONS to prevent serious injury to yourself and others or prevent your equipment from being damaged.

PMCS PROCEDURES

- (1) Obey all WARNINGS and CAUTIONS when you do PMCS.
- (2) Name, caution, and instruction plates should be easy to read. If they are dirty or corroded, clean them, and coat them with lacquer. See TM 43-0319 for instructions.
- (3) If something doesn't work, troubleshoot it using the troubleshooting procedures (WP 0005 00).
- (4) Do the semiannual PMCS every 1500 miles (2400 km) of operation or no later than 6 months after the last semiannual PMCS.

**PREVENTIVE MAINTENANCE CHECKS AND SERVICES (PMCS), INCLUDING
LUBRICATION INSTRUCTIONS — Continued**

0155 00

- (5) Always do your PMCS in the same order so it gets to be a habit. With practice, you'll spot anything that is wrong.
- (6) Keep your vehicle clean. Dirt, grease, oil, and debris only get in the way, and may cover up a serious problem. Clean your vehicle as you work and as needed.
- (7) Use cleaning compound (WP 0928 00, Item 19) on metal surfaces. Use general purpose detergent (WP 0928 00, Item 35) and water when you clean rubber or plastic parts.
- (8) You need to know how fluid leaks affect your vehicle. Definitions of the types and classes of leaks are given in General Maintenance Instructions below. You need to know them to determine the condition of your vehicle. Learn them. REMEMBER: WHEN IN DOUBT, NOTIFY YOUR SUPERVISOR!

GENERAL MAINTENANCE INSTRUCTIONS**SCOPE**

This section contains safety warnings, guidelines, and general maintenance instructions. They should be followed when doing maintenance procedures authorized for unit maintenance level.

1. PREPARATION FOR MAINTENANCE

- a. *PERSONNEL SAFETY.* Practice all shop safety procedures and read all warnings in this manual.
- b. *PROPER EQUIPMENT.* Get tools and equipment before starting a maintenance task. See RPSTL (TM 9-2350-277-24P), and the maintenance task for tools, equipment, parts, and materials.
- c. *WHAT TO DISCARD.* Parts to discard, such as lockwashers, locknuts, and gaskets, are listed in the maintenance tasks. If the step does not say to discard a part, the part should be saved. It may be used later or may be repaired.
- d. *HANDLING TECHNIQUES.*
 - 1) Avoid damage to parts during removal, cleaning, inspection, repair, and installation procedures. Nicks, scratches, and dents caused by careless handling could result in equipment failure.
 - 2) Dirt can damage parts and cause malfunctions. Make sure all air and fluid openings, lines, and hoses are capped or plugged during maintenance procedures.
- e. *IDENTIFICATION.*
 - 1) During removal, tag parts to ensure proper installation.
 - 2) During removal, tag leads on electrical parts to ensure proper installation. Tag each lead as it is removed.

**PREVENTIVE MAINTENANCE CHECKS AND SERVICES (PMCS), INCLUDING
LUBRICATION INSTRUCTIONS — Continued**

0155 00

- f. *TORQUING.* Where needed, torque values are listed in the maintenance task. When torquing, use one of the star pattern sequences below unless otherwise stated in the maintenance task.

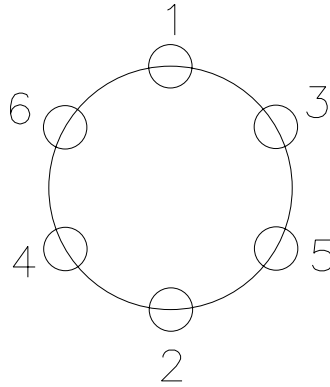

6-HOLE PATTERN

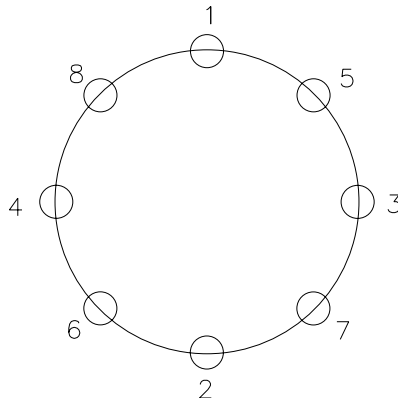

8-HOLE PATTERN

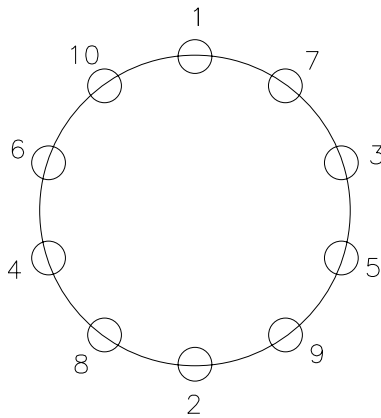

10-HOLE PATTERN

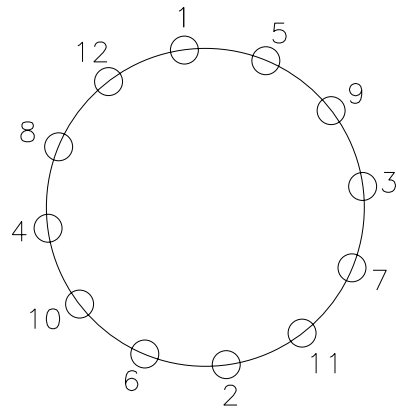

12-HOLE PATTERN

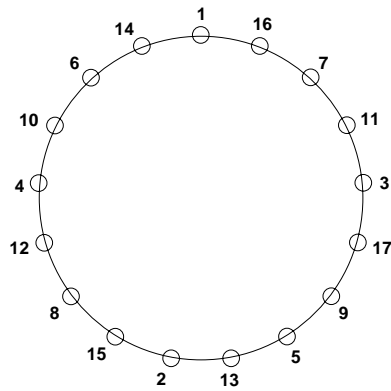

17-HOLE PATTERN

g. *USE OF TORQUE WRENCH ADAPTERS AND THE CONVERSION FORMULA.*

- 1) The torque values given in the text of this manual are the actual values that must be applied to the nut or screw for proper maintenance.
- 2) Some tasks require the use of a torque wrench adapter when the nut or screw cannot be reached with a regular socket on the end of the torque wrench. When an adapter is used on a torque wrench, definite rules must be followed or the nut or screw will be over- or under-torqued. The center line of the adapter should be used in one of two positions:
 - a) One position is to have the adapter center line at right angles to the center line of the torque wrench. In this position, the indicator reading does not have to be calculated and it may be read direct.

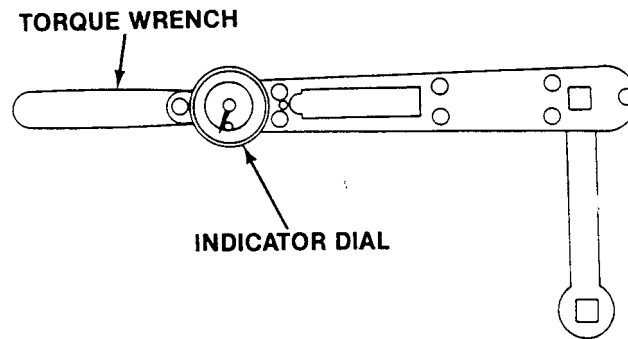

- b) The other position is to have the center line of the adapter in line with the center line of the torque wrench. In this case, the adapter adds to the overall length of the torque wrench and makes the dial or scale reading less than the actual torque applied to the nut or screw. To prevent overtightening and damage to equipment, you must calculate a corrected dial or scale reading.

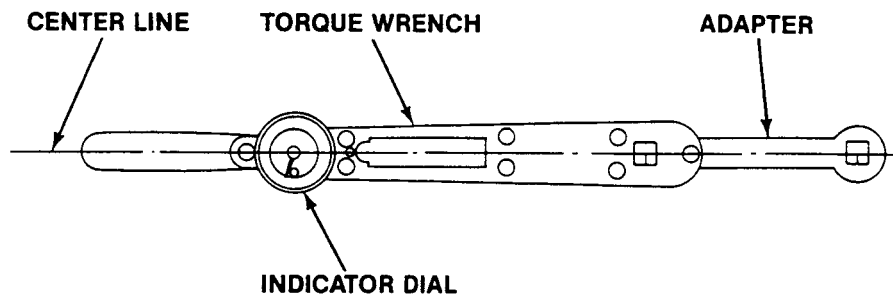

- 3) To determine the corrected scale or dial reading, use the following formula and refer to the example.

NOTE

The length of the torque wrench is measured from the center of the handle to the center of the drive. The length of the adapter is measured from the center of the drive to the center of the wrench.

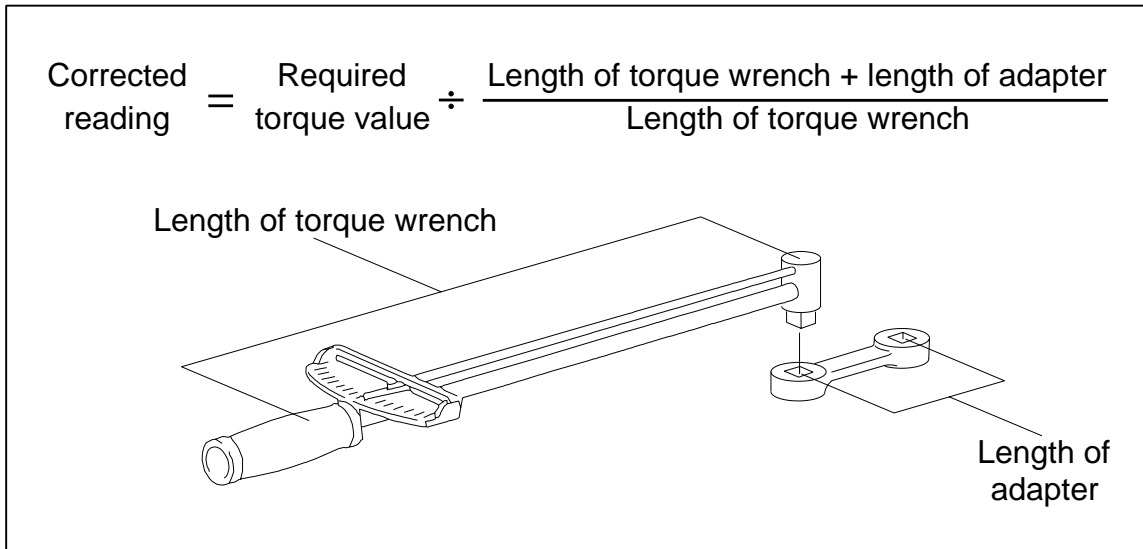

The following example is taken from the PMCS, Item 10 (page 0155 00-57). The torque wrench measured 12 inches and the adapter measured 3 inches. The required torque is 130–140 lb-ft and the corrected reading is 104–112 lb-ft.

**PREVENTIVE MAINTENANCE CHECKS AND SERVICES (PMCS), INCLUDING
LUBRICATION INSTRUCTIONS — Continued**

0155 00

EXAMPLE

Replace missing track tension adjuster screws. Tighten loose screws to 130-140 lb-ft (176-190 N·m) torque. Use adapter (WP 0926 00, Item 4) and torque wrench (WP 0926 00, Item 85). Adapter measures 3 inches from drive center to 12-point wrench center. 1/2-inch drive torque wrench measures 12 inches from handle center to drive center.
To determine the corrected reading for this task, use the formula as follows:

Corrected reading	=	Required torque value	÷	$\frac{\text{Length of torque wrench + length of adapter}}{\text{Length of torque wrench}}$
Corrected reading	=	130 lb-ft	÷	$\frac{12 \text{ inches} + 3 \text{ inches}}{12 \text{ inches}}$
Corrected reading	=	130 lb-ft	÷	$\frac{15 \text{ inches}}{12 \text{ inches}}$
Corrected reading	=	130 lb-ft	÷	1.25
Corrected reading	=	104 lb-ft		

Repeat last step for other torque value.

Corrected reading	=	140 lb-ft	÷	1.25	=	112 lb-ft
-------------------	---	-----------	---	------	---	-----------

**PREVENTIVE MAINTENANCE CHECKS AND SERVICES (PMCS), INCLUDING
LUBRICATION INSTRUCTIONS — Continued**

0155 00

2. CLEANING

- a. *GENERAL.* Cleaning is very important. Clean all parts well and keep clean during maintenance. Dirt or foreign matter can cause malfunctions and equipment failure. General cleaning procedures are detailed in steps b through m. Special cleaning procedures are covered in the task relating to the specific part. Clean after repair and before assembly.
- b. *CLEAN EVERY PART.* Clean every part well after removal and before installation. Clean parts such as housings, covers, and dipsticks before removal. Avoid getting dirt and foreign matter in a system. Inspect and cap all air and fluid openings, lines, and hoses.
- c. *HANDLE WITH CARE.* Use care when handling parts during cleaning and maintenance. Nicks, scratches, dents, or burrs can prevent proper assembly or cause malfunctions after assembly. Keep hands free of grease. Grease collects dirt. Cover or wrap parts to protect from dirt.
- d. *AVOID ABRASIVES.* Except where specially called for in a task, don't use abrasives, files, wire brushes, or sharp tools. On some surfaces, finish is important to the operation of close-fitting parts.
- e. *REMOVAL AGENTS.* Remove gum or old grease deposits by soaking parts in cleaning compound (WP 0928 00, Item 19). Scrub with a brush. Use crocus cloth (WP 0928 00, Item 1) to remove minor surface defects.

WARNING

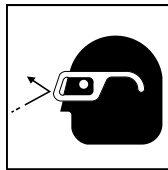

Air pressure in excess of 30 psi (207 kpa) can injure personnel. Do not direct pressurized air at yourself or others. Always wear goggles.

CAUTION

Lye or caustic mixtures will damage metal surfaces. Do not use lye or caustic mixtures to clean metal surfaces.

- f. *STEAM CLEANING.* If steam cleaning is used, dry clean parts at once with compressed air. Apply a thin film of clean oil to surfaces that are not painted to prevent rusting. Never use lye or caustic mixtures that will corrode or etch metal surfaces.
- g. *LUBRICATION OF NEW BEARINGS.* See TM 9-214 for cleaning and lubrication procedures. Bearings that have been in service should also be lubricated.

h. *CASTINGS.*

WARNING

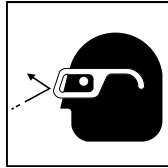

Air pressure in excess of 30 psi (207 kpa) can injure personnel. Do not direct pressurized air at yourself or others. Always wear goggles.

- 1) Clean inner and outer surfaces of casting with cleaning compound (WP 0928 00, Item 19). Dry casting with compressed air.
 - 2) Remove sludge and gum deposits with a brush.
 - 3) Blow out all tapped holes with compressed air.
- i. *BALL BEARINGS.* Bearings require special cleaning techniques. See TM 9-214 for cleaning and maintenance procedures for ball bearings.
- j. *OIL PASSAGES.*
- 1) Make sure oil passages are not clogged.
 - 2) Clean oil passages and break up any sludge or gum deposits.

WARNING

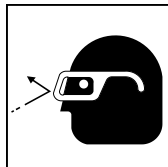

Air pressure in excess of 30 psi (207 kpa) can injure personnel. Do not direct pressurized air at yourself or others. Always wear goggles.

- 3) Flush oil passages with cleaning compound (WP 0928 00, Item 19). Dry parts with compressed air.
- k. *OIL SEALS, ELECTRIC CABLES, AND FLEXIBLE HOSES.*

CAUTION

Cleaning compound causes leather, rubber, and synthetic materials to become brittle. Do not use cleaning compound to clean seals, cables, and flexible hoses.

- 1) Clean seals, cables, and flexible hoses with general purpose detergent (WP 0928 00, Item 35) and water. Dry with wiping rag (WP 0928 00, Item 65).

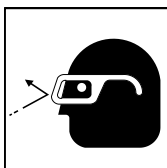
WARNING

Air pressurized in excess of 30 psi (207 kpa) can injure personnel. Do not direct pressurized air at yourself or others. Always wear goggles.

- i. *INSERTS*. Blow out insert holes with compressed air.
- m. *GASKETS*. If a gasket is being removed, scrape old gasket material and sealant off mating surface. Clean mating surface with cleaning compound (WP 0928 00, Item 19). Dry with wiping rag (WP 0928 00, Item 65).

3. INSPECTION

All removed parts must be inspected with care. Replace parts if damage or wear exceeds allowable limits.

- a. *GENERAL*. Procedures for inspection will be the same for most parts. General inspection procedures are given in steps b through p below. Special inspection procedures are covered in the task as needed.
- b. *CASTINGS*.
 - 1) Inspect all castings and forgings for breaks, cracks, and wear or scoring that would impair function.
 - 2) Inspect machined surfaces for nicks, burrs, and raised metal. Mark damaged areas for repair.
 - 3) Use straightedge to check all mounting flanges on housings and supports for bends. Inspect mating flanges for stains which would indicate oil leakage.
 - 4) Inspect all threaded parts for damaged or stripped threads.
- c. *NEEDLE ROLLER BEARINGS*. Inspect bearings for free and smooth rotation, and broken or missing rollers. Also look for tightness of fit in bearing bores. Inspect bearing races for wear and color changes due to heat. See TM 9-214 for inspection procedures.
- d. *STUDS*. Inspect all studs for stripped or damaged threads, bent or loose condition, and signs of stretching.
- e. *GEARS*. Inspect gears for burrs, wear, cracked or broken teeth, and pitting at tooth contact areas.
- f. *BUSHINGS AND BUSHING-TYPE BEARINGS*.
 - 1) Check all bushings and bushing-type bearings for secure fit in casting. Check for color changes which could mean overheating. Inspect for size, scoring, out-of-roundness, burrs, sharp edges, and signs of seizing.
 - 2) Check for dirt in oil holes and in bushing-type bearings. Oil holes and grooves must be clean and not damaged.
- g. *OIL SEALS*.
 - 1) Inspect feather edge of oil seals for tears, fraying, hardening, and cracking.
 - 2) Replace metal-covered oil seals when there are signs of damage or oil leakage.
- h. *CORE HOLE PLUGS*. Inspect core hole plugs for signs of leakage. Replace damaged core hole plugs.

**PREVENTIVE MAINTENANCE CHECKS AND SERVICES (PMCS), INCLUDING
LUBRICATION INSTRUCTIONS — Continued**

0155 00

- i. *INSERTS*.
 - 1) Inspect inserts for cracks and stripped or damaged threads.
 - 2) Check inserts for loose fit.
 - 3) Inspect armor mounting inserts and hull screw holes for loose or missing plugs and setscrews, as required.
 - j. *GREASE SEALS, PREFORMED PACKINGS, AND GASKETS*.
 - 1) Inspect composition seals, rings, and preformed packings for wear, brittleness, cracks, cuts, and damage.
 - 2) Inspect lip seals for cracks, wear, cuts, and brittleness. Inspect springs and seal shells for damage.
 - 3) Gaskets and seals on electrical parts may be reused. Inspect gaskets and seals for wear, nicks, cuts, and torn or missing gasket material. Replace gasket, if needed.
 - k. *SPLINED PARTS*. Inspect splined parts for burrs, wear, twisted, cracked, or broken splines.
 - l. *THREADED PARTS*. Inspect all threaded parts for burrs and stripped or damaged threads.
 - m. *RETAINING RINGS*. Inspect retaining rings for nicks, burrs, defects, loss of tension, and wear.
 - n. *SPRINGS*. Inspect springs for wear, defects, breaks, and loss of tension or compression. Inspect springs using a spring tester.
 - o. *SHAFTS AND SPINDLES*. Inspect shafts and spindles for excessive wear, binding, scores, cracks, burrs, and obstructed oil passages.
 - p. *ELECTRICAL PARTS*.
 - 1) Inspect electrical parts before you install them. Look for mildewed, corroded, or burned parts.
 - 2) Inspect electrical parts for pinched or loose wires and for cracked or broken wires, circuit cards, relays, and connectors.
 - 3) Inspect insulation and heatshrink tubing for cracks, tears, burns, or missing material.
4. **REPAIR**
- a. *GENERAL*. General repair procedures are given in steps b through m below. Special repairs are covered in the task. After repair, clean all parts well.
 - b. *CASTINGS*.
 - 1) Replace all cracked or broken castings.
 - 2) Repair minor damage to machined surfaces of castings with crocus cloth (WP 0928 00, Item 1). Replace any part with defects that cannot be corrected or which will impair function.
 - c. Repair minor surface bends by working bent surface of casting across sheet of crocus cloth (WP 0928 00, Item 1) on surface plate. Replace bent castings which would impair assembly or function.
 - d. *BALL BEARINGS*. See TM 9-214 for inspection and maintenance for ball bearings.
 - e. *NEEDLE ROLLER BEARINGS*. See TM 9-214 for inspection and maintenance of needle roller bearings.
 - f. *BUSHINGS AND BUSHING-TYPE BEARINGS*. Replace bushings and bushing-type bearings if they are loose, scored, or have color change due to heat. When you replace bushings and bushing-type bearings, check nearby parts for damage or wear.

**PREVENTIVE MAINTENANCE CHECKS AND SERVICES (PMCS), INCLUDING
LUBRICATION INSTRUCTIONS — Continued**

0155 00

- g. *OIL SEALS*. Oil seals must be replaced when thin feather edge is damaged or when seal material is brittle.
- 1) Press damaged oil seal from casting. Be careful not to damage bore.
 - 2) When oil seal bore is damaged so an oil-tight seal is impossible, replace casting or adapter. Remove slight nicks, burrs, and scratches with crocus cloth (WP 0928 00, Item 1) dipped in cleaning compound (WP 0928 00, Item 19).
- h. *GREASE SEALS, PREFORMED PACKINGS, GROMMETS, AND GASKETS*. Seals, preformed packings, grommets, and gaskets should be replaced when removed unless otherwise stated in the maintenance task. They should not be reused.
- i. *THREADED PARTS*. Repair all parts that have stripped or damaged threads by chasing threads with a used tap or die. Replace parts that cannot be repaired.
- j. *RETAINING RINGS*.
- 1) Retaining rings should be replaced when removed unless otherwise stated in the maintenance task. They should not be reused.
 - 2) Some retaining rings are beveled on one side. When installing this type of ring, the beveled side must face the part to be retained.
- k. *SPRINGS*. Discard springs that have defects. Load and height inspection data, where needed, are given in maintenance procedures.
- l. *SHAFTS AND SPINDLES*.
- 1) Replace shafts and spindles that show signs of wear, binding, scores, cracks, burrs, or clogged oil passages.

WARNING

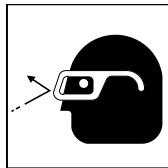

Air pressure in excess of 30 psi (207 kpa) can injure personnel. Do not direct pressurized air at yourself or others. Always wear goggles.

- 2) Remove obstructions with compressed air or by probing with soft wire.
 - 3) Remove burrs and minor surface defects with a crocus cloth (WP 0928 00, Item 1).
- m. *ELECTRICAL PARTS*.
- 1) Replace corroded or burned parts and parts which show signs of mildew.
 - 2) Tighten loose connections.
 - 3) Replace cracked or broken wires, circuit cards, relays, and connectors.
 - 4) Replace cracked, torn, or burned insulation and heatshrink tubing.
- n. *INSERTS*. Replace insert when threads are stripped or when insert is cracked or loose.
- 1) Drill and remove damaged insert from casting.
 - 2) Install new insert in casting using suitable replacement tool.
 - 3) Install plugs in armor mounting inserts, as required.

**PREVENTIVE MAINTENANCE CHECKS AND SERVICES (PMCS), INCLUDING
LUBRICATION INSTRUCTIONS — Continued**

0155 00

- 4) Install setscrews in hull armor mounting screw holes, as required.

5. FLUID LEAKS AND CHECKING FOR LEAKS

- a. *GENERAL.* Fluid leaks in hoses and fluid lines affect the carrier parts operation. The types and classes of leaks are given below.

CLASS I	Fluid Seepage is not great enough to form drops, but it is shown by wetness or color changes.
CLASS II	Fluid Leakage is great enough to form drops, but drops do not drip from the item being checked or inspected.
CLASS III	Fluid Leakage is great enough to form drops that fall from the item being checked or inspected

NOTE

You are allowed to operate equipment with minor water or oil leaks (Class I or II). You must consider how much fluid the item or system being checked or inspected can hold. When in doubt, notify your supervisor. Any fuel or Class III leaks will make the vehicle NOT READY/AVAILABLE.

- b. *CHECKING FOR LEAKS AFTER A MAINTENANCE TASK.* After doing maintenance on a part which involves hoses or fluid lines, check for leaks. If leaks occur after you have done a replace or repair task, find the source of the leak. Correct the problem. Follow these procedures.
- 1) Do visual inspections to find the source of the leak.
 - a) Check for cracks on housing or cover.
 - b) Check that screws and any connections are not loose or overtight.
 - 2) If you cannot see the source of the leak, check the items listed below.
 - a) Check that preformed gasket is not bent, or pinched.
 - b) Check machined surfaces for fit and cleanliness.
 - c) If leak persists, notify supervisor.
- c. *CHECKING FOR LEAKS USING CHALK TEST.* Following replacement, repair, or adjustment of a ramp, door, hatch cover, access panel, or rubber seal, check for leaks by performing a chalk test. Use the following procedure:
- 1) Use chalk or chalk powder to coat area around seal.
 - 2) Close ramp, door, hatch cover, or panel.
 - 3) Open ramp, door, hatch cover, or panel.
 - 4) Check for unbroken chalk line on mating surface. Where chalk does not stick to mating surface, there is a leak in the seal surface.
 - 5) If a leak is found, perform adjustment to correct the problem.

6. WARM-UP ENGINE

To warm up the engine for a maintenance or troubleshooting task, do the following:

- a. Cover air inlet grill.
- b. Start engine (see your -10).
- c. Release parking brake and apply service brake.

WARNING



When shifting gear selector into PIVOT, vehicle can move if steering yoke is moved from centered position. Soldiers can be killed or injured. Hold brake pedal on. Clear all soldiers away from vehicle when shifting into PIVOT. Do not move yoke from centered position.

- d. Move gear selector to PIVOT. Do not turn steering yoke.
- e. Raise engine speed to 1500 rpm until normal operating temperature is reached.
- f. Lower engine rpm to idle.
- g. Move gear selector to SL.
- h. Set parking brake.
- i. Stop engine (see your -10).
- j. Uncover air inlet grille.
- k. Make sure MASTER SWITCH is OFF.

**PREVENTIVE MAINTENANCE CHECKS AND SERVICES (PMCS), INCLUDING
LUBRICATION INSTRUCTIONS — Continued**

0155 00

LUBRICATION TABLES

The following tables are used during PMCS lubrication checks.

Intervals (on-condition or hard time) and the related man-hour times are based on normal operation. The man-hour time specified is the time you need to do all the services prescribed for a particular interval. Hard time intervals will be indicated by one of the following symbols as appropriate: Daily (D), Weekly (W), Monthly (M), Semi-Annually (S), and Annually (A). On-condition (OC) oil sample intervals shall be applied unless changed by the Army Oil Analysis Program (AOAP) Laboratory. Change the hard time interval if lubricants are contaminated or if you are operating equipment under adverse operating conditions, including longer-than-usual operating hours. The hard time intervals may be extended during periods of low activity if adequate preservation precautions are taken. Hard time intervals will be applied to oil changes in the event AOAP Laboratory support is not available.

On-condition (OC) AOAP Laboratory determined oil change intervals shall be applied instead of hard time intervals such as hourly, calendar, or mileage, unless otherwise notified. The services will be required when directed by an Army Analysis Program (AOAP) Laboratory which has analyzed the oil for serviceability.

Clean fittings before lubricating. Clean parts with cleaning compound (WP 0928 00, Item 19).

Unless specifically identified, all procedures apply to M58, M113A3, M577A3, M1059A3, M1064A3, and M1068A3 carriers. ■

NOTE

Park carrier on level ground to check oil levels. Check/lubricate all oil and grease fitting points after washing or fording.

ARMY OIL ANALYSIS PROGRAM (AOAP) — AOAP is an effective maintenance diagnostic tool and not a maintenance substitute. TB 43-0210 or TM 9-2300-422-23&P must not be interpreted to mean AOAP minimizes, in any way, the need to employ good maintenance practices and strong maintenance disciplines.

SAMPLING REQUIREMENTS — Samples may be taken without WARMING a component to operating temperature if the equipment has been operated within the last 30 days. If the equipment has not been operated within the last 30 days, the components must be brought to operating temperature. These requisites apply to both routine and special sampling. Oil samples must not be taken immediately after oil is added. When oil sampling valve is not available to take oil sample, use a vampire pump.

OIL CAN POINTS — Every 1500 miles, semi-annually or as required, lubricate fan tensioner, ramp hinges, ramp door hinges, power plant door hinges, driver's, commander's and cargo hatch hinges, control linkage pins and shafts and seat control. Use OE/HDO or OEA as appropriate.

**PREVENTIVE MAINTENANCE CHECKS AND SERVICES (PMCS), INCLUDING
LUBRICATION INSTRUCTIONS — Continued**

0155 00

Table 1. Engine

LUBRICANTS/ COMPONENTS Interval=OC Manhours=0.5	MAXIMUM CAPACITY	EXPECTED TEMPERATURE (For Arctic Operation, Refer To FM 9-207)		
		Above +32°F (Above 0°C)	+40°F TO -10°F (+5°C to -23°C)	0°F to -65°F (-18°C to -54°C)
OE/HDO (MIL-L-2104D) OR OEA (MIL-L-46167), LUBRICATING OIL, INTERNAL COMBUSTION ENGINE Engine	18 qts.	OE/HDO-15/40	OE/HDO- 15/40	OEA
(MIL-L-21260) PRESERVATION OIL		PE 30-1	PE 30-1	

**PREVENTIVE MAINTENANCE CHECKS AND SERVICES (PMCS), INCLUDING
LUBRICATION INSTRUCTIONS — Continued**

0155 00

Table 2. Fuel Filter

LUBRICANTS/ COMPONENTS Interval=S Manhours=0.3	MAXIMUM CAPACITY	EXPECTED TEMPERATURE (For Arctic Operation, Refer To FM 9-207)		
		Above +32°F (Above 0°C)	+40°F TO -10°F (+5°C to -23°C)	0°F to -65°F (-18°C to -54°C)
DIESEL FUEL VV-F-800	100 gal.	DF-2	DF-1	DF-A
JP8 MIL-T-83133	100 gal.	JP8	JP8	JP8

**PREVENTIVE MAINTENANCE CHECKS AND SERVICES (PMCS), INCLUDING
LUBRICATION INSTRUCTIONS — Continued**

0155 00

Table 3. Transmission

LUBRICANTS/ COMPONENTS Interval=OC Manhours=0.5 Interval=S Manhours=0.2	MAXIMUM CAPACITY	EXPECTED TEMPERATURE (For Arctic Operation, Refer To FM 9-207)		
		Above +32°F (Above 0°C)	+40°F TO -10°F (+5°C to -23°C)	0°F to -65°F (-18°C to -54°C)
OE/HDO (MIL-L-2104D) OR OEA (MIL-L-46167), LUBRICATING OIL, INTERNAL COMBUSTION ENGINE Transmission	Initial fill - 12 gal. or 57 qts. Refill after oil change — approx. 36 qts.	OE/HDO-15/40	OE/HDO- 15/40	OEA
(MIL-L-21260) PRESERVATION OIL		PE 10-1	PE 10-1	

**PREVENTIVE MAINTENANCE CHECKS AND SERVICES (PMCS), INCLUDING
LUBRICATION INSTRUCTIONS — Continued**

0155 00

Table 4. Final Drive

LUBRICANTS/ COMPONENTS Interval=S Manhours= 0.5	MAXIMUM CAPACITY	EXPECTED TEMPERATURE (For Arctic Operation, Refer To FM 9-207)		
		Above +32°F (Above 0°C)	+40°F TO -10°F (+5°C to -23°C)	0°F to -65°F (-18°C to -54°C)
OE/HDO (MIL-L-2104D) OR OEA (MIL-L-46167) LUBRICATING OIL, INTERNAL COMBUSTION ENGINE Final Drives	3 1/2 qts or 7 pints (FULL mark on gauge rod)	OE/HDO-15/40	OE/HDO-15/40	OEA

**PREVENTIVE MAINTENANCE CHECKS AND SERVICES (PMCS), INCLUDING
LUBRICATION INSTRUCTIONS — Continued**

0155 00

Table 5. Fan Gearbox

LUBRICANTS/ COMPONENTS Interval=S Manhours= 0.4	MAXIMUM CAPACITY	EXPECTED TEMPERATURE (For Arctic Operation, Refer To FM 9-207)		
		Above +32°F (Above 0°C)	+40°F TO -10°F (+5°C to -23°C)	0°F to -65°F (-18°C to -54°C)
OE/HDO (MIL-L-2104D) LUBRICATING OIL, INTERNAL COMBUSTION ENGINE Fan Gearbox	18 oz. or 3/4 pt.	OE/HDO-15/40	OE/HDO-15/40	OEA

**PREVENTIVE MAINTENANCE CHECKS AND SERVICES (PMCS), INCLUDING
LUBRICATION INSTRUCTIONS — Continued**

0155 00

Table 6. Pulley Support Arm

LUBRICANTS/ COMPONENTS Interval=S Manhours= 0.4	MAXIMUM CAPACITY	EXPECTED TEMPERATURE (For Arctic Operation, Refer To FM 9-207)		
		Above +32°F (Above 0°C)	+40°F TO -10°F (+5°C to -23°C)	0°F to -65°F (-18°C to -54°C)
GAA (MIL-G-10924) GREASE, AUTOMOTIVE AND ARTILLERY	As required	ALL TEMPERATURES		

**PREVENTIVE MAINTENANCE CHECKS AND SERVICES (PMCS), INCLUDING
LUBRICATION INSTRUCTIONS — Continued**

0155 00

Table 7. Hydraulic System

LUBRICANTS/ COMPONENTS Interval=S Manhours= 1.0	MAXIMUM CAPACITY	EXPECTED TEMPERATURE (For Arctic Operation, Refer To FM 9-207)		
		Above +32°F (Above 0°C)	+40°F TO -10°F (+5°C to -23°C)	0°F to -65°F (-18°C to -54°C)
FRH (MIL-H-46170) HYDRAULIC FLUID, RUST INHIBITED, FIRE RESISTANT, (MIL-H-46170) Ramp System	3 1/2 qts or 7 pints	ALL TEMPERATURES		

**PREVENTIVE MAINTENANCE CHECKS AND SERVICES (PMCS), INCLUDING
LUBRICATION INSTRUCTIONS — Continued**

0155 00

Table 8. Steering Control and Foot Brake Cross-Shaft Bearings

LUBRICANTS/ COMPONENTS Interval=S Manhours=0.3	MAXIMUM CAPACITY	EXPECTED TEMPERATURE (For Arctic Operation, Refer To FM 9-207)		
		Above +32°F (Above 0°C)	+40°F TO -10°F (+5°C to -23°C)	0°F to -65°F (-18°C to -54°C)
GAA (MIL-G-10924) GREASE, AUTOMOTIVE AND ARTILLERY Steering Control Bearings Foot-Brake Cross-Shaft Bearings	As Required	ALL TEMPERATURES		

**PREVENTIVE MAINTENANCE CHECKS AND SERVICES (PMCS), INCLUDING
LUBRICATION INSTRUCTIONS — Continued**

0155 00

Table 9. Towing Pintle

LUBRICANTS/ COMPONENTS Interval=S Manhours=0.1	MAXIMUM CAPACITY	EXPECTED TEMPERATURE (For Arctic Operation, Refer To FM 9-207)		
		Above +32°F (Above 0°C)	+40°F TO -10°F (+5°C to -23°C)	0°F to -65°F (-18°C to -54°C)
GAA (MIL-G-10924) GREASE AUTOMOTIVE AND ARTILLERY Towing Pintle	As Required	ALL TEMPERATURES		

**PREVENTIVE MAINTENANCE CHECKS AND SERVICES (PMCS), INCLUDING
LUBRICATION INSTRUCTIONS — Continued**

0155 00

Table 10. Road and Idler Wheel Bearings, Road and Idler Wheel Support Arm Bearings

LUBRICANTS/ COMPONENTS Interval=S Manhours=1.4	MAXIMUM CAPACITY	EXPECTED TEMPERATURE (For Arctic Operation, Refer To FM 9-207)		
		Above +32°F (Above 0°C)	+40°F TO -10°F (+5°C to -23°C)	0°F to -65°F (-18°C to -54°C)
GAA (MIL-G-10924) GREASE AUTOMOTIVE AND ARTILLERY Road and Idler Wheel Bearings	As Required	ALL TEMPERATURES		
GAA (MIL-G-10924) GREASE AUTOMOTIVE AND ARTILLERY Road and Idler Wheel Support Arm Bearings	As Required	ALL TEMPERATURES		

PREVENTIVE MAINTENANCE CHECKS AND SERVICES (PMCS), INCLUDING
LUBRICATION INSTRUCTIONS — Continued

0155 00

Table 11. Tachometer and Speedometer Shafts

LUBRICANTS/ COMPONENTS Interval=A Manhours=0.1	MAXIMUM CAPACITY	EXPECTED TEMPERATURE (For Arctic Operation, Refer To FM 9-207)		
		Above +32°F (Above 0°C)	+40°F TO -10°F (+5°C to -23°C)	0°F to -65°F (-18°C to -54°C)
GIA (MIL-G-23827) GREASE, INSTRUMENT, AIRCRAFT	As Required	ALL TEMPERATURES		
GAA (MIL-G-10924) GREASE, AUTOMOTIVE AND ARTILLERY	As Required	ALL TEMPERATURES		
OE/HDO (MIL-L-2104D) OR OEA (MIL-L-46167) LUBRICATING OIL, INTERNAL COMBUSTION ENGINE	As Required	ALL TEMPERATURES		

**PREVENTIVE MAINTENANCE CHECKS AND SERVICES (PMCS), INCLUDING
LUBRICATION INSTRUCTIONS — Continued**

0155 00

Table 12. Universal Joint

LUBRICANTS/ COMPONENTS Interval=S Manhours=0.5	MAXIMUM CAPACITY	EXPECTED TEMPERATURE (For Arctic Operation, Refer To FM 9-207)		
		Above +32°F (Above 0°C)	+40°F TO -10°F (+5°C to -23°C)	0°F to -65°F (-18°C to -54°C)
GAA (MIL-G-10924) GREASE AUTOMOTIVE AND ARTILLERY Universal Joint	As Required	ALL TEMPERATURES		

Lubrication Charts

Table 13. Lubricants For Engine Applications

LUBRICANT		EXPECTED TEMPERATURE
OE/HDO (MIL-L-2104) Lubricating Oil, ICE	OE/HDO-15/40 (O-1236)	0°F to 120°F (-18°C to 49°C)
	OE/HDO-30 (O-238)	10°F to 120°F (-12°C to 49°C)
	OE/HDO-40 (N/A)	20°F to 120°F (-7°C to 49°C)
<p>OEA (MIL-L-46167) Lubricating Oil, ICE, Arctic (If OEA lubricant is required to met the low expected-temperature range, OEA lubricant is to be used in lieu of OE/HDO lubricant for all expected temperatures where OE/HDO is specified.)</p>	OEA (O-183)	-65°F to 40°F (-54°C to 4°C)

**PREVENTIVE MAINTENANCE CHECKS AND SERVICES (PMCS), INCLUDING
LUBRICATION INSTRUCTIONS — Continued**

0155 00

Table 14. Lubricants For Transmission Applications

LUBRICANT		EXPECTED TEMPERATURE
OE/HDO (MIL-L-2104) Lubricating Oil, ICE, Tactical	OE/HDO-15/40 (O-1236)	0°F to 120°F (-18°C to 49°C)
<p>OEA (MIL-L-46167) Lubricating Oil, ICE, Arctic (If OEA lubricant is required to met the low expected-temperature range, OEA lubricant is to be used in lieu of OE/HDO lubricant for all expected temperatures where OE/HDO is specified.)</p>	OEA (O-183)	-65°F to 40°F (-54°C to 4°C)

Table 15. Fluids For Hydraulic System Applications

LUBRICANT		EXPECTED TEMPERATURE
FRH (MIL-H-46170) Hydraulic Fluid, Rust Inhibited Fire Resistant, Synthetic Hydrocarbon Base	FRH	-40°F to 120°F (-40°C to 49°C)

Table 16. Lubricants For Exposed Gear, Chain And Wire Rope Applications

LUBRICANT		EXPECTED TEMPERATURE
CW-II (MIL-L-18458) Lubricating Oil, Chain, Wire Rope, and Exposed Gear	CW-IIC (O-203)	70°F to 120°F (21°C to 49°C)
	CW-IIB (N/A)	30°F to 90°F (-1°C to 32°C)
	CW-IIA (O-199)	-30°F to 50°F (-34°C to 10°C)
GO (MIL-L-2105) Lubricating Oil, Gear Multipurpose	GO-75 (O-186)	-70°F to -10°F (-57°C to 23°C)

PREVENTIVE MAINTENANCE CHECKS AND SERVICES (PMCS), INCLUDING
LUBRICATION INSTRUCTIONS — Continued

0155 00

Table 17. Fluids For General Purpose Applications

LUBRICANT		EXPECTED TEMPERATURE
PL-S (VV-L-800) Lubricating Oil, General Purpose, Preservative, Water Displacing, Low Temperature	PL-S (O-190)	-70°F to 120°F (-57°C to 49°C)
PL-M (MIL-L-3150) Lubricating Oil, Preservative, Medium	PL-M (O-192)	30°F to 120°F (-1°C to 49°C)

EXPLANATION OF PMCS TABLE ENTRIES

(1) **Item Number Column** — Numbers in this column are for reference. When completing DA Form 2404 (Equipment Inspection and Maintenance Worksheet), include the item number for the check/service indicating a fault. Item numbers also appear in the order that you must do the checks and services for the intervals listed.

(2) **Interval Column** — This column tells you how often you must perform the checks/services. Semi-Annual checks/services must be performed every six months or after 1500 (2400 km) of operation.

(3) **Man-Hour Column** — This column gives the man-hours (to the nearest 10th of an hour) needed to complete the prescribed lubrication service. This column is used only for lubrication services.

(4) **Item To Be Checked or Serviced Column** — This column lists the item to be checked or serviced.

(5) **Crewmember/Procedure Column** — This column gives the procedure you must do to check or service the item listed in the *Item To Be Checked or Serviced* column to know if the equipment is ready or available for its intended mission or for operation. You must do the procedure at the time stated in the interval column.

(6) **Equipment Not Ready/Available If: Column** — Information in this column tells you what faults will keep your equipment from being capable of performing its primary mission. If you perform check and service procedures that show faults as listed in this column, do not operate the equipment. Follow standard operating procedures for maintaining the equipment or reporting equipment failure.

PREVENTIVE MAINTENANCE CHECKS AND SERVICES (PMCS), INCLUDING
LUBRICATION INSTRUCTIONS — Continued

0155 00

Table 18. Semi-Annual Unit Level Preventive Maintenance Checks and Services for M113A3 FOV

ITEM NO.	INTERVAL	MAN-HOUR	ITEM TO BE CHECKED OR SERVICED	CREWMEMBER PROCEDURE	EQUIPMENT NOT READY/ AVAILABLE IF:
1	Semi-Annual		Road Test	<p style="text-align: center;">CAUTION</p> <p>Do not allow engine to operate for prolonged periods if outside air temperature is less than 85°F (29°C) and gauge is above 200°F (93°C) or outside air temperature is above 85°F (29°C) and gauge is above 225°F (100°C). Serious damage to engine may result.</p> <p style="text-align: center;">NOTE</p> <p>Be sure that all operator level PMCS in your -10 have been completed prior to performing this PMCS. Any non-mission capable faults must be corrected prior to road test.</p> <p style="text-align: center;">NOTE</p> <p>Check instruments, gauges, and warning lights for normal indications as outlined in your -10.</p> <p style="text-align: center;">NOTE</p> <p>Review all operator recorded problems prior to road test.</p> <p style="text-align: center;">NOTE</p> <p>When conditions prevent a road test, perform engine idle test (Step 3a.)and governed no load test (Step 4a.).</p> <p>a. Start engine (see your -10). Perform a road test. Drive carrier at least 5 miles (8 km).</p>	Any Class III leak or damage that would prevent operation of the carrier.
a	Semi-Annual		Left and Right Steering	<p style="text-align: center;">CAUTION</p> <p>Power plant can be damaged. Do not pivot steer when carrier is moving except in a track failure emergency.</p>	



PREVENTIVE MAINTENANCE CHECKS AND SERVICES (PMCS), INCLUDING LUBRICATION INSTRUCTIONS — Continued

0155 00

ITEM NO.	INTERVAL	MAN-HOUR	ITEM TO BE CHECKED OR SERVICED	<u>CREWMEMBER</u> PROCEDURE	EQUIPMENT NOT READY/ AVAILABLE IF:
b	Semi-Annual		Steering in Forward and Reverse Range	a. Check steering wheel for left and right turns. If carrier does not turn left or right when wheel is turned, troubleshoot steering system (WP 0063 00). b. Check steering in forward range and in reverse angle. If carrier does not make a complete turn after steering wheel is turned to the left and right, troubleshoot steering system (WP 0063 00).	Binding, grabbing, unusual noise, vibration or carrier fails to turn.
c	Semi-Annual		Carrier Braking	a. Check carrier braking. If carrier does not stop when brakes are applied, troubleshoot brake adjustment (WP 0064 00).	Carrier fails to stop.
d	Semi-Annual		Carrier Shifting in All Ranges	a. Check shifting of carrier in all ranges. If carrier does not respond properly to selected driving range, troubleshoot gear selection system (WP 0065 00).	Carrier fails to shift into selected range.
e	Semi-Annual		Speed	a. When the vehicle is at normal temperature, it shall be capable of sustaining the speed of 40 mph.	
f	Semi-Annual		Drift	a. The vehicle's directional drift shall not exceed three feet in 100 feet of travel at 25 mph ± 5 mph.	
g	Semi-Annual		Acceleration	a. At normal temperature, standing still, with the engine at idle rpm and the transmission in 1-4 range, the vehicle shall accelerate on a smooth, level, hard surface from zero to 20 mph in 11 seconds or less.	
h	Semi-Annual		Turning	a. Verify that the vehicle can make a 360° turn and pivot to the right and left. Pivot with the selector in PV. The vehicle should be brought to a full stop before reversing direction. Stop engine (see your -10).	

PREVENTIVE MAINTENANCE CHECKS AND SERVICES (PMCS), INCLUDING LUBRICATION INSTRUCTIONS — Continued

0155 00

ITEM NO.	INTERVAL	MAN-HOUR	ITEM TO BE CHECKED OR SERVICED	CREWMEMBER PROCEDURE	EQUIPMENT NOT READY/AVAILABLE IF:
2	Semi-Annual		After Road Test	<p style="text-align: center;">WARNING</p> <div style="text-align: center;">  </div> <p>Failure to set the parking brake and block the road wheel can allow the carrier to move and result in injury or death. Always engage the parking brake and block the road wheels before working on the carrier.</p> <p style="text-align: center;">WARNING</p> <div style="text-align: center;">  </div> <p>Never perform stall check. Transmission can be damaged. Personnel may be injured.</p> <p>a. Immediately after road test cautiously feel all wheel and idler hubs for noticeable difference in temperature between hubs. An overheated hub indicates that bearing is out of adjustment, poorly lubricated, or unserviceable.</p> <p>b. Check temperature of shock absorbers. They should feel warm. A cold shock has failed.</p> <p>c. Visually check inside, outside, and underneath carrier for any fuel, oil, or hydraulic leaks.</p>	<p>A hub that is out of adjustment, poorly lubricated or unserviceable.</p> <p>Any Class III leaks or cold shocks.</p>

**PREVENTIVE MAINTENANCE CHECKS AND SERVICES (PMCS), INCLUDING
LUBRICATION INSTRUCTIONS — Continued**

0155 00

ITEM NO.	INTERVAL	MAN-HOUR	ITEM TO BE CHECKED OR SERVICED	<u>CREWMEMBER</u> PROCEDURE	EQUIPMENT NOT READY/ AVAILABLE IF:
3	Semi-Annual		Idle Test	<p style="text-align: center;"><u>CAUTION</u></p> <p>Avoid lengthy engine idling. This causes coolant temperature to drop below operating temperature and can shorten engine life.</p> <p>a. Run engine at 800 rpm for 3-5 minutes with range selector in 2-3 range and brakes locked until operating temperature is reached.</p> <p>b. If outside temperature is less than 85°F (29°C), normal operating temperature should be 160°F to 200°F (71° to 93° C). If outside air temperature is greater than 85°F (29°C), normal operating temperature should be 160° to 225°F (71° to 107°C)</p> <p>c. With range selector in SL, engine should idle smoothly at 650 to 700 rpm.</p> <p>d. High or low engine idle speed is usually caused by accelerator linkage being out of adjustment. Adjust linkage if necessary (WP 0214 00).</p> <p>e. Rough idling is usually caused by faulty injector timing and rack setting, faulty injectors or air in the injection system. Notify direct support maintenance.</p>	<p>Engine runs hot or rough.</p> <p>Tachometer above 700 or below 650 rpm.</p>
4	Semi-Annual		Governed No Load Test	<p>a. Run engine at 800 rpm for 3-5 minutes with range selector in 1 range and brakes locked until normal engine operating temperature is reached.</p> <p>b. If outside temperature is less than 85°F (29°C), normal operating temperature should be 160°F to 200°F (71° to 93° C). If outside air temperature is greater than 85°F (29°C), normal operating temperature should be 160° to 225°F (71° to 107°C)</p> <p>c. With range selector in SL, slowly open throttle control until accelerator is fully depressed.</p>	<p>Engine runs hot or rough.</p>

PREVENTIVE MAINTENANCE CHECKS AND SERVICES (PMCS), INCLUDING LUBRICATION INSTRUCTIONS — Continued

0155 00

ITEM NO.	INTERVAL	MAN-HOUR	ITEM TO BE CHECKED OR SERVICED	<u>CREWMEMBER</u> PROCEDURE	EQUIPMENT NOT READY/ AVAILABLE IF:
5 6	Semi-Annual	1.2	Engine and Transmission Oil	<p style="text-align: center;">CAUTION</p> <p>When you suspect a faulty governor, do not exceed 3,000 rpm engine speed for more than 2 or 3 seconds.</p> <p>d. Engine speed may exceed 3,000 rpm momentarily, but should stabilize at 2,925 to 2,975 rpm.</p> <p>DELETED</p> <p>a. With engine at idle, sample engine and transmission oil.</p> <p style="text-align: center;">NOTE</p> <p>Do not sample new or overhauled engine until second oil change. Use hard time requirement on new/overhauled engine.</p> <p style="text-align: center;">NOTE</p> <p>DO NOT ADD OIL immediately prior to taking oil samples. When operation checks and services indicate the need to replenish oil levels WAIT until after taking samples or before prolonged operation of components will adversely effect oil analysis results.</p> <ol style="list-style-type: none"> 1) Obtain two sample bottles from the unit AOAP monitor. 2) Start engine (see your -10). If required, operate carrier to bring engine and transmission up to normal operating temperatures. Refer to Sampling Requirements page 0155 00-15. 3) Stop carrier and set the brakes (see your -10). 4) Place range selector in SL position (steering lock) and keep engine running. 5) Remove driver's power plant access panel and open power plant access door (see your -10). 	<p>If governor cuts in and out, or surges at this speed, adjustments are needed.</p> <p>AOAP recommends oil change.</p>

**PREVENTIVE MAINTENANCE CHECKS AND SERVICES (PMCS), INCLUDING
LUBRICATION INSTRUCTIONS — Continued**

0155 00

ITEM NO.	INTERVAL	MAN-HOUR	ITEM TO BE CHECKED OR SERVICED	<u>CREWMEMBER</u> PROCEDURE	EQUIPMENT NOT READY/ AVAILABLE IF:
				6) With engine running remove dust caps from engine and transmission oil sampling valves. 7) Open sample valve on engine oil filter and drain a small amount of oil into a container to clear valve of grit and contamination. (Properly dispose of container and oil upon completion of sample taking.) Fill sampling bottle to the neck shoulder and seal it. Attach DA Form 2026 to sample bottle.	

**PREVENTIVE MAINTENANCE CHECKS AND SERVICES (PMCS), INCLUDING
LUBRICATION INSTRUCTIONS — Continued**

0155 00

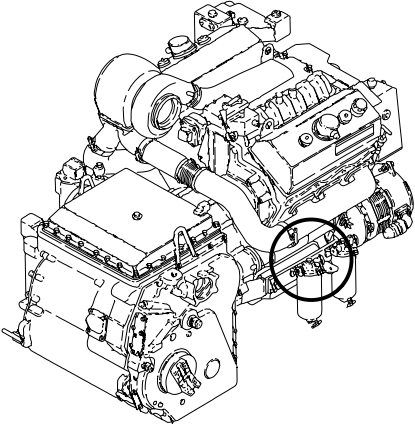
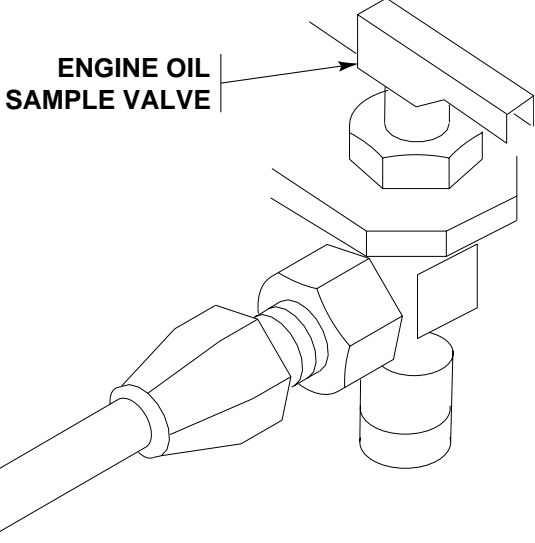
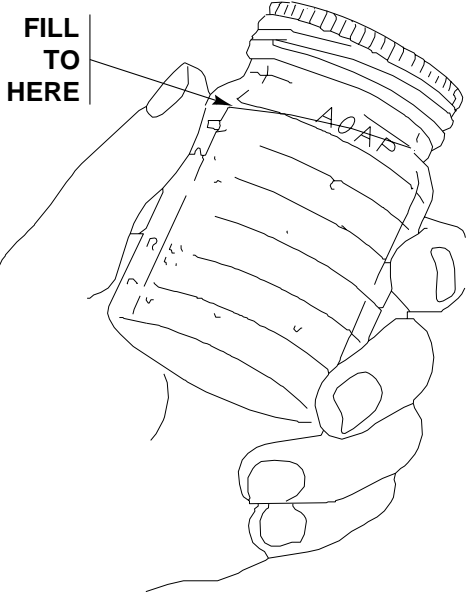
ITEM NO.	INTERVAL	MAN-HOUR	ITEM TO BE CHECKED OR SERVICED	CREWMEMBER PROCEDURE	EQUIPMENT NOT READY/AVAILABLE IF:
				 <p>ENGINE OIL SAMPLE VALVE</p>	
				 <p>FILL TO HERE</p>	

**PREVENTIVE MAINTENANCE CHECKS AND SERVICES (PMCS), INCLUDING
LUBRICATION INSTRUCTIONS — Continued**

0155 00

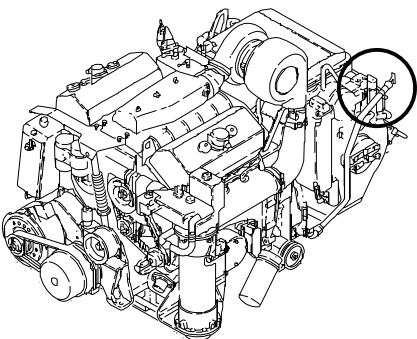
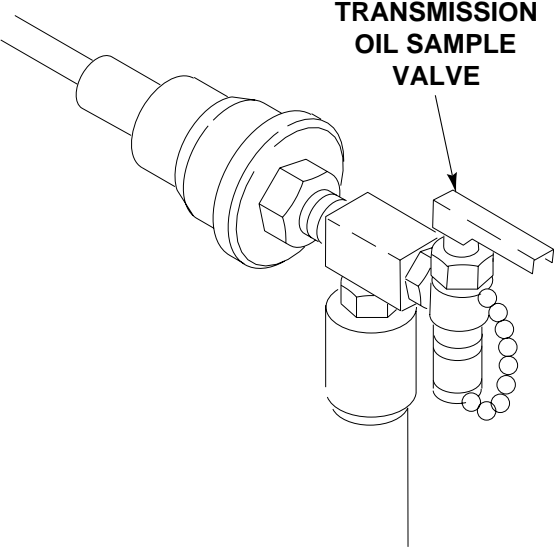
ITEM NO.	INTERVAL	MAN-HOUR	ITEM TO BE CHECKED OR SERVICED	<u>CREWMEMBER</u> PROCEDURE	EQUIPMENT NOT READY/ AVAILABLE IF:
				<p>8) Close sample valve and install dust cap.</p> <p>9) Take oil sample from transmission in the same manner as in Steps 6a6 - 6a8.</p>  <p style="text-align: center;">TRANSMISSION OIL SAMPLE VALVE</p>	
				<p>10) Stop engine (see your -10).</p> <p>11) Install driver's compartment power plant access panel and secure carrier.</p>	

**PREVENTIVE MAINTENANCE CHECKS AND SERVICES (PMCS), INCLUDING
LUBRICATION INSTRUCTIONS — Continued**

0155 00

ITEM NO.	INTERVAL	MAN-HOUR	ITEM TO BE CHECKED OR SERVICED	<u>CREWMEMBER</u> PROCEDURE	EQUIPMENT NOT READY/ AVAILABLE IF:
				<p>12) Deliver sample bottles to the unit AOAP monitor.</p> <p style="text-align: center;">NOTE</p> <p>For location of nearest AOAP Laboratory and complete information about AOAP, refer to TB 43-0210.</p> <p style="text-align: center;">NOTE</p> <p>If AOAP laboratory is not available, drain engine oil and change filter element/gasket every 150 hours/1500 miles or semi-annually. Transmission oil should be drained and filter element/gaskets changed every 150 hours/1500 miles or semi-annually. See AOAP TB 43-0211</p> <p style="text-align: center;">NOTE</p> <p>Engine and transmission filters need to be replaced every 150 hours/1500 miles or semi-annually, even when following AOAP procedures.</p> <p>b. ON CONDITION — Drain engine oil.</p>	

**PREVENTIVE MAINTENANCE CHECKS AND SERVICES (PMCS), INCLUDING
LUBRICATION INSTRUCTIONS — Continued**

0155 00

ITEM NO.	INTERVAL	MAN-HOUR	ITEM TO BE CHECKED OR SERVICED	<u>CREWMEMBER</u> PROCEDURE	EQUIPMENT NOT READY/ AVAILABLE IF:
				<p style="text-align: center;">WARNING</p> <div style="text-align: center;">  </div> <p>Hot parts can burn you. Use care when you work near hot power unit.</p> <p style="text-align: center;">NOTE</p> <p>Drain oil only when hot after operation. Allow oil to drain thoroughly.</p> <ol style="list-style-type: none"> 1) Remove access cover from bottom of hull (WP 0450 00). 2) Place a suitable container under engine oil pan. 	

**PREVENTIVE MAINTENANCE CHECKS AND SERVICES (PMCS), INCLUDING
LUBRICATION INSTRUCTIONS — Continued**

0155 00

ITEM NO.	INTERVAL	MAN-HOUR	ITEM TO BE CHECKED OR SERVICED	<u>CREWMEMBER</u> PROCEDURE	EQUIPMENT NOT READY/ AVAILABLE IF:
				<ol style="list-style-type: none"> 3) Remove plug from engine oil pan and drain oil into container. 4) Inspect plug and oil for metallic particles. If metal chips are found, notify direct support maintenance. 5) Clean and install drain plug in engine oil pan. 	

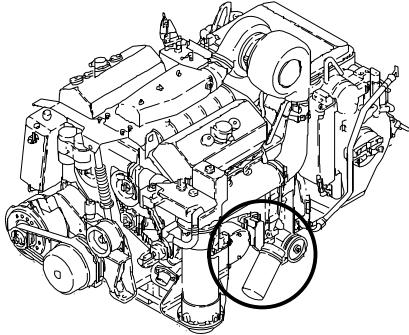
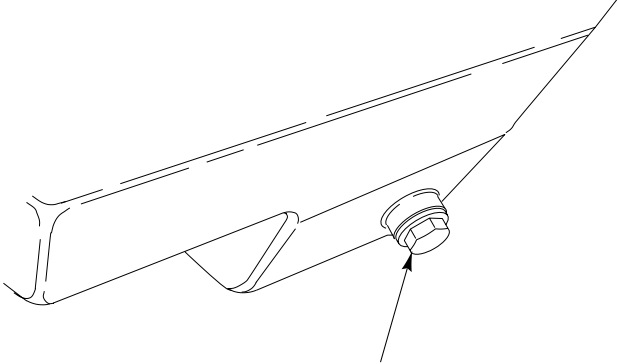
ENGINE OIL DRAIN

PREVENTIVE MAINTENANCE CHECKS AND SERVICES (PMCS), INCLUDING LUBRICATION INSTRUCTIONS — Continued

0155 00

ITEM NO.	INTERVAL	MAN-HOUR	ITEM TO BE CHECKED OR SERVICED	CREWMEMBER PROCEDURE	EQUIPMENT NOT READY/AVAILABLE IF:
				<p>6) Install new oil filter element (WP 0165 00). Filter element will be replaced each time an engine oil change is required.</p>	
 <p>The image contains two technical drawings. The upper drawing is a perspective view of an engine block with various components labeled. A circle highlights the location of the oil filter on the side of the engine. The lower drawing is a detailed view of the oil filter assembly, showing a cylindrical filter element with a top cap. An arrow points from the text 'ENGINE OIL FILTER' to the filter element.</p>					

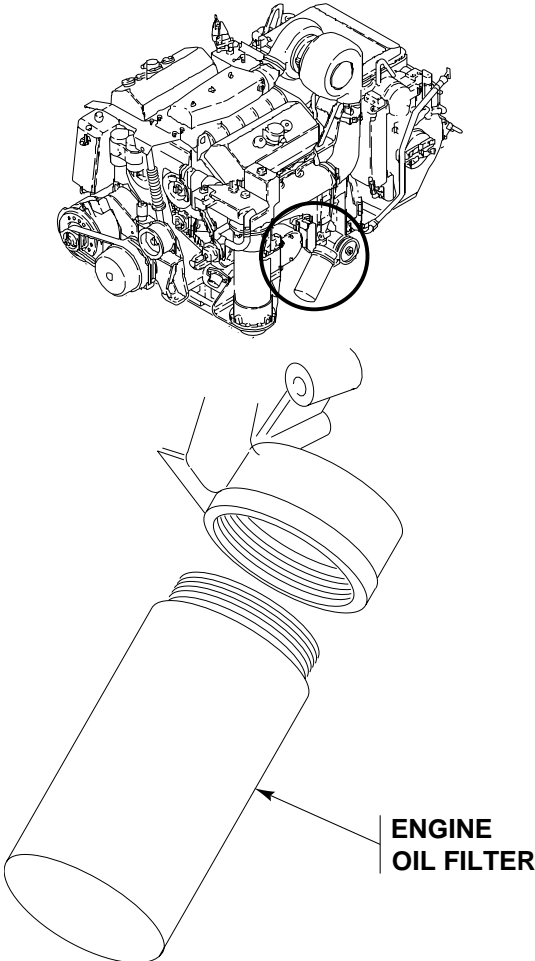
PREVENTIVE MAINTENANCE CHECKS AND SERVICES (PMCS), INCLUDING LUBRICATION INSTRUCTIONS — Continued

0155 00

ITEM NO.	INTERVAL	MAN-HOUR	ITEM TO BE CHECKED OR SERVICED	CREWMEMBER PROCEDURE	EQUIPMENT NOT READY/ AVAILABLE IF:
				7) Fill engine with approximately 22 quarts of OE/HDO or OEA to bring level between F and L marks on gauge rod. See Engine Lubrication Table (Table 1, page 0155 00-16).	

The diagram shows a detailed view of an engine assembly. Two callout lines point to specific components: one points to the top of the oil fill cap labeled 'ENGINE OIL FILL', and the other points to the oil level gauge rod labeled 'ENGINE OIL LEVEL (CHECK LEVEL)'. The gauge rod has 'F' and 'L' marks indicating the correct oil level range.

PREVENTIVE MAINTENANCE CHECKS AND SERVICES (PMCS), INCLUDING LUBRICATION INSTRUCTIONS — Continued

0155 00

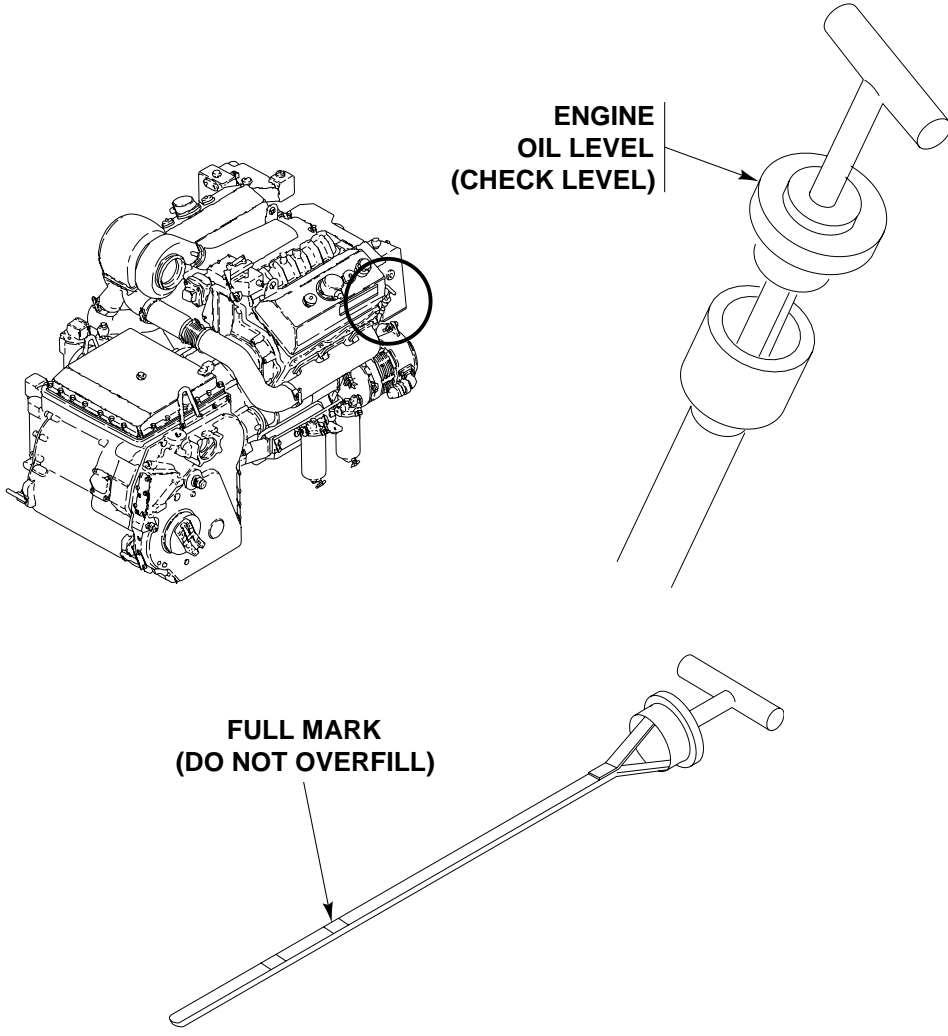
ITEM NO.	INTERVAL	MAN-HOUR	ITEM TO BE CHECKED OR SERVICED	<u>CREWMEMBER</u> PROCEDURE	EQUIPMENT NOT READY/ AVAILABLE IF:
				<p>c. If engine has been filled with preservation oil (MIL-L-21260, Grade PE 30-1), leave this oil in engine until first scheduled oil change. Maintain operating oil level by adding applicable grade oil (OE/HDO or OEA). When first scheduled oil change is made, refill engine oil with applicable grade of oil. See Engine Lubrication Table (Table 1, page 0155 00-16).</p> <p>Replace filter element each time an engine oil change is required (WP 0165 00).</p>	

**PREVENTIVE MAINTENANCE CHECKS AND SERVICES (PMCS), INCLUDING
LUBRICATION INSTRUCTIONS — Continued**

0155 00

ITEM NO.	INTERVAL	MAN-HOUR	ITEM TO BE CHECKED OR SERVICED	<u>CREWMEMBER</u> PROCEDURE	EQUIPMENT NOT READY/ AVAILABLE IF:
				<p>d. ON CONDITION — Drain transmission oil.</p> <p style="text-align: center;">WARNING</p> <div style="text-align: center;">  </div> <p>Hot parts can burn you. Use care when you work near hot power unit.</p> <p style="text-align: center;">NOTE</p> <p>Drain oil (36 quarts) only when hot after operation. Allow oil to drain for 1 hour if time permits.</p> <ol style="list-style-type: none"> 1) Remove access cover from bottom of hull (WP 0450 00). 2) Place a suitable container under transmission drain tube. 3) Remove plug from drain tube and drain oil into container. 4) Inspect plug and oil for metallic particles. If metal chips are found, notify direct support maintenance. 	

PREVENTIVE MAINTENANCE CHECKS AND SERVICES (PMCS), INCLUDING LUBRICATION INSTRUCTIONS — Continued

0155 00

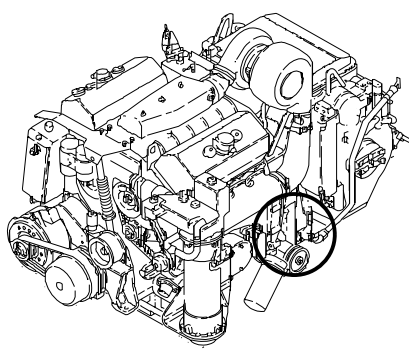
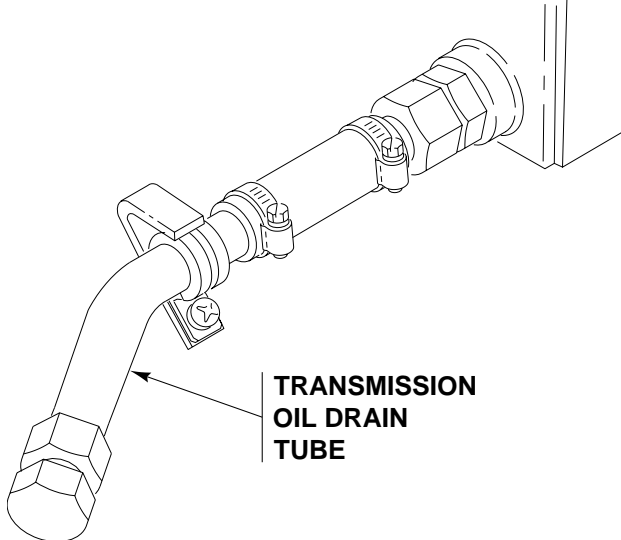
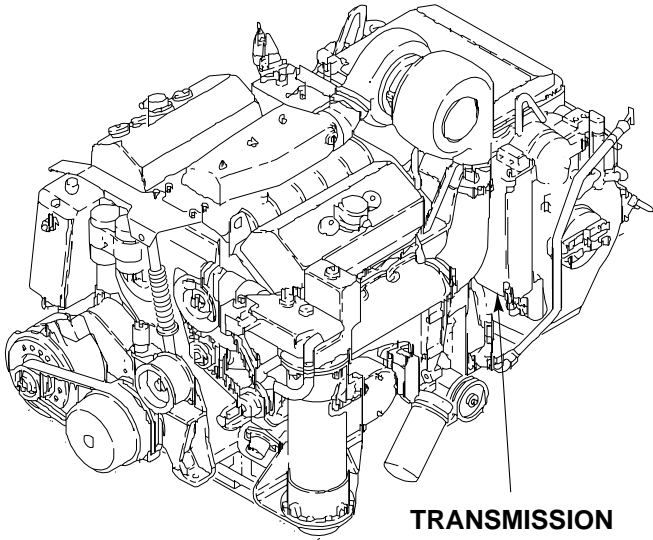
ITEM NO.	INTERVAL	MAN-HOUR	ITEM TO BE CHECKED OR SERVICED	CREWMEMBER PROCEDURE	EQUIPMENT NOT READY/AVAILABLE IF:
				5) Clean and install drain plug in oil drain tube.	
				 <p>TRANSMISSION OIL DRAIN TUBE</p>	
				6) Install new transmission oil filter element and gasket.	
			 <p>TRANSMISSION OIL FILTER</p>		

PREVENTIVE MAINTENANCE CHECKS AND SERVICES (PMCS), INCLUDING LUBRICATION INSTRUCTIONS — Continued

0155 00

ITEM NO.	INTERVAL	MAN-HOUR	ITEM TO BE CHECKED OR SERVICED	CREWMEMBER PROCEDURE	EQUIPMENT NOT READY/ AVAILABLE IF:
				<p>7) Fill transmission with approximately 36 quarts (refill capacity) or 57 quarts (initial fill) of OE/HDO or OEA, to bring level between FULL and ADD marks on gauge rod. See Transmission Lubrication Table (Table 3, page 0155 00-18).</p>	

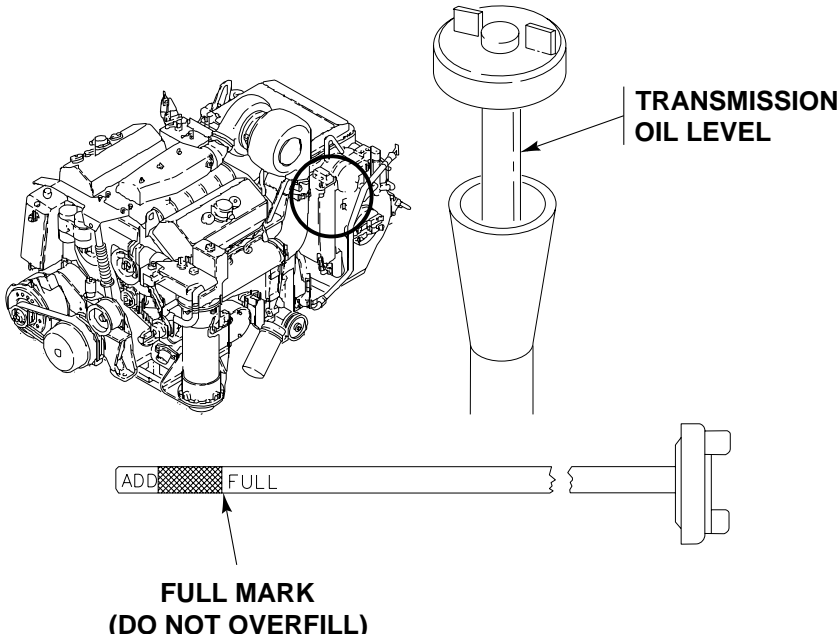

The diagram illustrates the transmission oil level checking process. On the left, a line drawing of an engine shows the transmission location circled. To the right, a vertical gauge rod is shown with a cap and a label 'TRANSMISSION OIL LEVEL' pointing to the rod. Below this, a detailed view of the gauge rod shows a hatched section labeled 'ADD' and a solid section labeled 'FULL'. An arrow points to the 'FULL' section with the text 'FULL MARK (DO NOT OVERFILL)'.

**PREVENTIVE MAINTENANCE CHECKS AND SERVICES (PMCS), INCLUDING
LUBRICATION INSTRUCTIONS — Continued**

0155 00

ITEM NO.	INTERVAL	MAN-HOUR	ITEM TO BE CHECKED OR SERVICED	<u>CREWMEMBER</u> PROCEDURE	EQUIPMENT NOT READY/ AVAILABLE IF:
				<p>e. If transmission has been filled with preservation oil (MIL-L-21260, Grade PE 10-1), leave this oil in transmission until first scheduled oil change. Maintain operating oil level by adding applicable grade oil (OE/HDO or OEA). When first scheduled oil change is made, refill transmission with applicable oil (OE/HDO or OEA). Replace filter element (WP 0398 00) each time a transmission oil change is required. Use the following procedure when changing oil grade or when oil is contaminated.</p> <p style="text-align: center;">NOTE</p> <p>Transmission oil must be flushed when changing oil grade or when oil is contaminated.</p> <p>1) Operate carrier until coolant reaches normal operating temperature.</p> <p style="text-align: center;">NOTE</p> <p>Do not change transmission oil filter at this time.</p> <p>2) Drain transmission oil. 3) Fill transmission with new grade oil. 4) Operate transmission in 1-3 range with engine idling for 5-6 minutes. 5) Drain oil and change transmission oil filter. 6) Fill transmission with new grade oil. 7) Check oil level.</p>	

**PREVENTIVE MAINTENANCE CHECKS AND SERVICES (PMCS), INCLUDING
LUBRICATION INSTRUCTIONS — Continued**

0155 00

ITEM NO.	INTERVAL	MAN-HOUR	ITEM TO BE CHECKED OR SERVICED	<u>CREWMEMBER</u> PROCEDURE	EQUIPMENT NOT READY/ AVAILABLE IF:
				<p style="text-align: center;">WARNING</p> <div style="text-align: center;">  </div> <p>Hot parts can burn you. Use care when working with them.</p> <p style="text-align: center;">NOTE</p> <p>Drain oil only when hot after operation. Allow oil to drain for one hour if time permits.</p> <p style="text-align: center;">NOTE</p> <p>If AOAP laboratory is not available, drain engine oil and change filter element/gaskets every 150 hours/1500 miles or annually. Transmission oil should be drained and filter element/gaskets changed every 150 hours/1500 miles or annually. Transmission oil should be drained and filter element/gaskets changed every 150 hours/1500 miles or semi-annually.</p> <p>f. HARDTIME — Hardtime interval can be shortened if equipment operates under adverse conditions (For Arctic Operations, refer to FM 9-207. For Desert Operations, refer to FM 90-30). See Lubrication Charts.</p>	

**PREVENTIVE MAINTENANCE CHECKS AND SERVICES (PMCS), INCLUDING
LUBRICATION INSTRUCTIONS — Continued**

0155 00

ITEM NO.	INTERVAL	MAN-HOUR	ITEM TO BE CHECKED OR SERVICED	<u>CREWMEMBER</u> PROCEDURE	EQUIPMENT NOT READY/ AVAILABLE IF:
				<p style="text-align: center;"><u>CAUTION</u></p> <p>Engine and transmission can be damaged if filled above the full (F) mark on gauge rods.</p> <p style="text-align: center;"><u>NOTE</u></p> <p>Do not mix OE/HDO-15 W40 with single grade lubricants.</p> <p>g. Perform engine operational check.</p> <ol style="list-style-type: none"> 1) Start engine (see your -10) and check oil leaks at filter and drain plug. Stop engine (see your -10). 2) Inspect access cover on hull bottom and replace if damaged. 3) Install access cover on hull bottom (WP 0450 00). <p>h. Perform transmission operational check.</p> <ol style="list-style-type: none"> 1) Start engine (see your -10) and check oil leaks at transmission filter cover and drain plug. Recheck oil level. 2) Inspect access cover on hull bottom and replace if damaged (WP 0450 00). 3) Install access cover on hull bottom (WP 0450 00). 	<p>Any Class III Leaks.</p> <p>Any Class III Leaks.</p>

PREVENTIVE MAINTENANCE CHECKS AND SERVICES (PMCS), INCLUDING LUBRICATION INSTRUCTIONS — Continued

0155 00

ITEM NO.	INTERVAL	MAN-HOUR	ITEM TO BE CHECKED OR SERVICED	CREWMEMBER PROCEDURE	EQUIPMENT NOT READY/AVAILABLE IF:
				<p style="text-align: center;">NOTE</p> <p>Visual inspection of engine should not be justification for changing oil. Detergent oils may appear dark in color due to additives.</p> <p>i. Change oil and filters when converting from OE/HDO to OEA, PE 30-1 to OE/HDO, PE 10-1 to OE/HDO. See engine temperature key chart (Table 1, page 0155 00-16) and transmission temperature key chart (Table 3, page 0155 00-18). See Lubrication Charts.</p> <p>j. Every 150 hours/1500 miles or semi-annually remove and clean transmission breather using cleaning compound (WP 0928 00, Item 19). Dry breather and install on transmission (WP 0399 00).</p>	
<div data-bbox="435 1108 1377 1535"> </div>					

PREVENTIVE MAINTENANCE CHECKS AND SERVICES (PMCS), INCLUDING LUBRICATION INSTRUCTIONS — Continued

0155 00

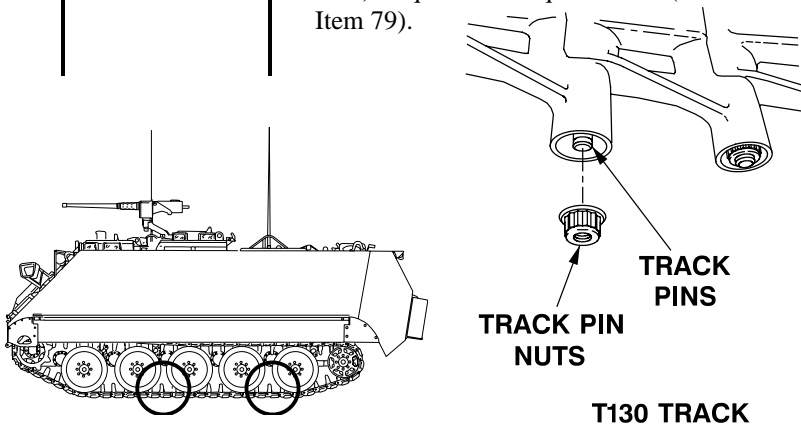
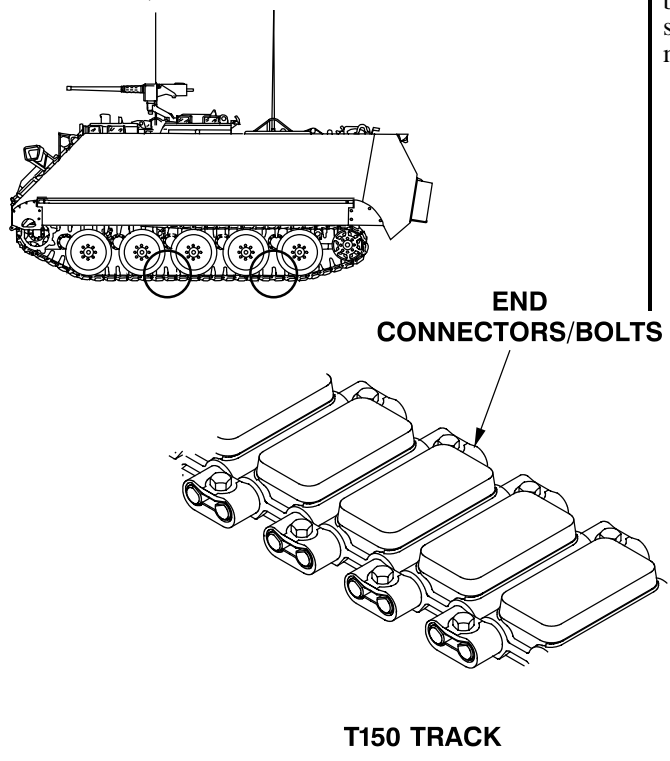
ITEM NO.	INTERVAL	MAN-HOUR	ITEM TO BE CHECKED OR SERVICED	CREWMEMBER PROCEDURE	EQUIPMENT NOT READY/ AVAILABLE IF:
7	Semi-Annual		Track Pin/Nuts (T130 Track Only)	<p>a. Check track pin nuts for looseness or cracks. Replace cracked nuts. Check track pins for stripped threads. Replace stripped track pins. Tighten loose nuts to 115-135 lb-ft (156-183 N·m) torque. Use torque wrench (WP 0926 00, Item 79).</p>  <p style="text-align: center;">T130 TRACK</p>	Any pins/nuts that are cracked, broken, bent, stripped, missing, or protruding.
7.1	Semi-Annual		Track Shoe End Connectors/Bolts (T150 Track Only)	<p>a. Check all end connectors/bolts for cracks and looseness. Check bolts for stripped threads. Tighten bolts to 400-430 lb-ft (543-588 N·m) torque. Use torque wrench (WP 0926 00, Item 79).</p>  <p style="text-align: center;">T150 TRACK</p>	Any connectors that are cracked, broken, bent, stripped, or missing.

PREVENTIVE MAINTENANCE CHECKS AND SERVICES (PMCS), INCLUDING LUBRICATION INSTRUCTIONS — Continued

0155 00

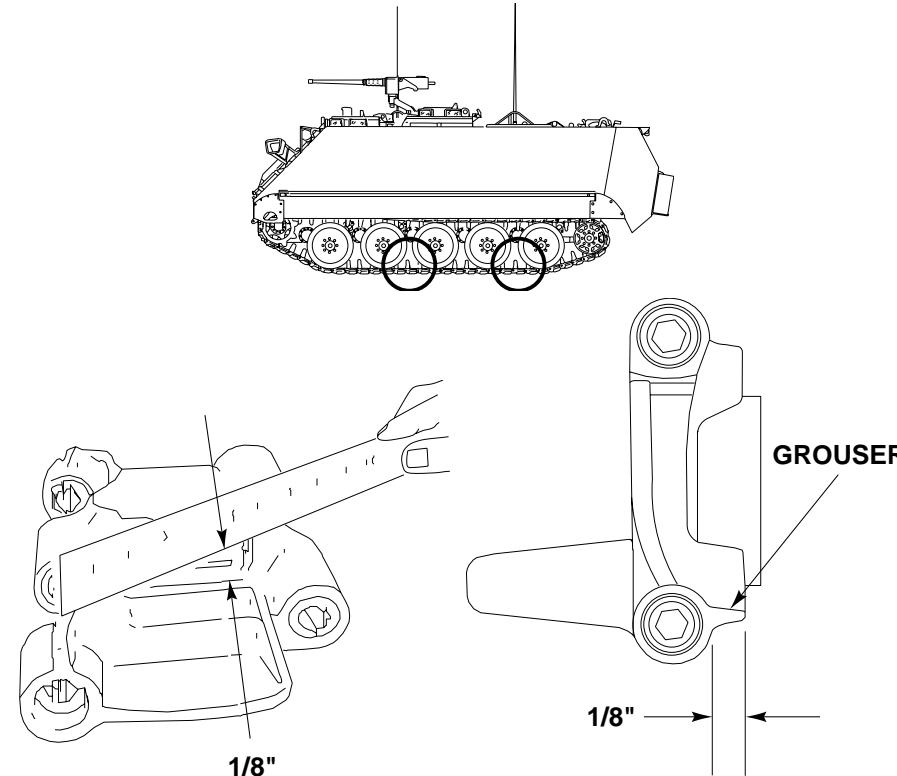
ITEM NO.	INTERVAL	MAN-HOUR	ITEM TO BE CHECKED OR SERVICED	CREWMEMBER PROCEDURE	EQUIPMENT NOT READY/ AVAILABLE IF:
8	Semi-Annual		Track Grouser (T130 Track Only)	<p>a. Check grouser for wear or cracks on both tracks. Replace track shoe if grouser measures less than 1/8" (3 mm) in height or if grouser is cracked.</p> 	Grouser is worn below 1/8" or cracked.
9	Semi-Annual		Track Shoe Pads and Mounting Studs/Nuts	<p>a. Check track shoes pads and mounting for looseness and stripped threads on both tracks. If mounting nuts are stripped, replace track shoe pad (T130 Track) (WP 0424 00) (T150 Track) (WP 0424 01). Tighten loose nuts to 135-155 lb-ft (183-210 N·m). Use torque wrench (WP 0926 00, Item 80).</p>	Studs/nuts are cracked, stripped, missing, or pad height is less than 1/16" above grouser (T130 Track). Studs/nuts are cracked, stripped, missing, or pad height is less than 1/16" above track shoe (T150 track).

PREVENTIVE MAINTENANCE CHECKS AND SERVICES (PMCS), INCLUDING
LUBRICATION INSTRUCTIONS — Continued

0155 00

ITEM NO.	INTERVAL	MAN-HOUR	ITEM TO BE CHECKED OR SERVICED	CREWMEMBER PROCEDURE	EQUIPMENT NOT READY/AVAILABLE IF:
----------	----------	----------	--------------------------------	----------------------	-----------------------------------

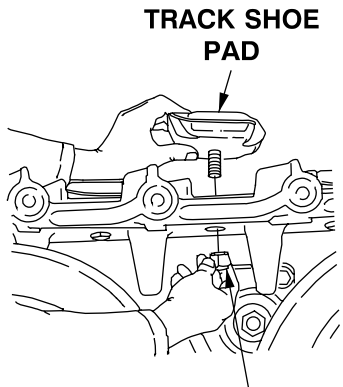

TRACK SHOE PAD

MOUNTING NUTS

T130 TRACK

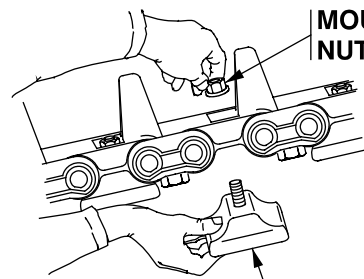

MOUNTING NUTS

TRACK SHOE PAD

T150 TRACK

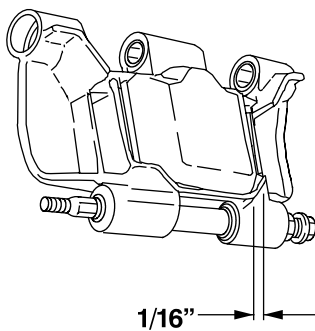

1/16"

T130 TRACK

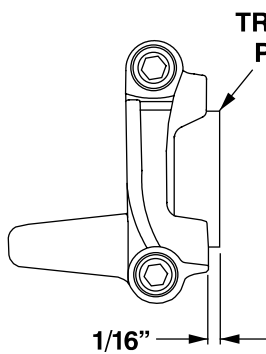

1/16"

TRACK PAD

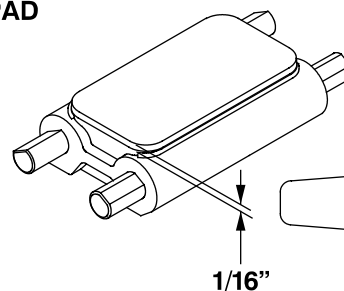

1/16"

T150 TRACK

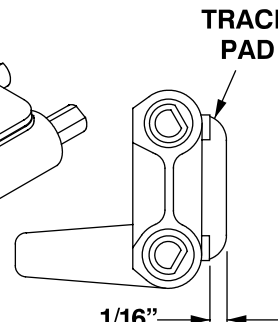

1/16"

TRACK PAD

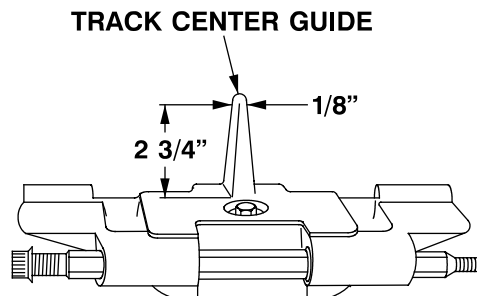

TRACK CENTER GUIDE

1/8"
2 3/4"

T130 TRACK

PREVENTIVE MAINTENANCE CHECKS AND SERVICES (PMCS), INCLUDING LUBRICATION INSTRUCTIONS — Continued

0155 00

ITEM NO.	INTERVAL	MAN-HOUR	ITEM TO BE CHECKED OR SERVICED	CREWMEMBER PROCEDURE	EQUIPMENT NOT READY/AVAILABLE IF:
10	Semi-Annual		Track Tension Adjuster Mounting Hardware	<p>a. Check track tension adjuster for broken hardware or cracks on both sides of the carrier. Replace adjuster if either end is cracked or broken. Replace broken adjuster mount (WP 0419 00).</p> <p style="text-align: center;">NOTE</p> <p>See Step 1g under General Maintenance Instructions for proper use of torque wrench adapters.</p> <p>b. Replace missing track tension adjuster screws. Tighten loose screws to 130-140 lb-ft (176-190 N·m) torque. Use adapter (WP 0926 00, Item 4) and torque wrench (WP 0926 00, Item 85).</p>	Hardware is broken, cracked, missing or stripped.

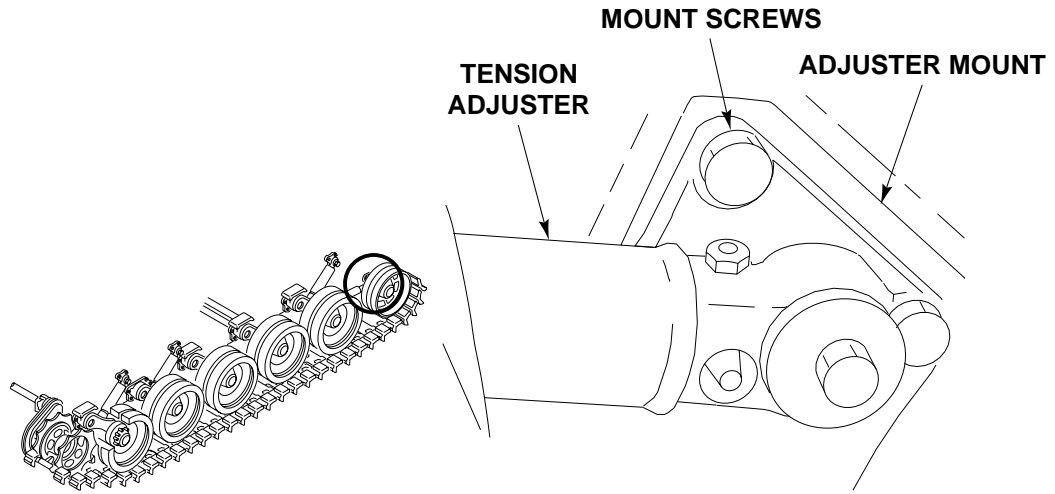

**PREVENTIVE MAINTENANCE CHECKS AND SERVICES (PMCS), INCLUDING
LUBRICATION INSTRUCTIONS — Continued**

0155 00

ITEM NO.	INTERVAL	MAN-HOUR	ITEM TO BE CHECKED OR SERVICED	<u>CREWMEMBER</u> PROCEDURE	EQUIPMENT NOT READY/ AVAILABLE IF:
11	Semi-Annual		Track Tension Adjuster Collar Leaks	a. Check for leaks around grease fittings, relief valve and collar of track tension adjuster. Replace leaking track adjuster (WP 0419 00).	Any leaks or fitting will not accept grease.

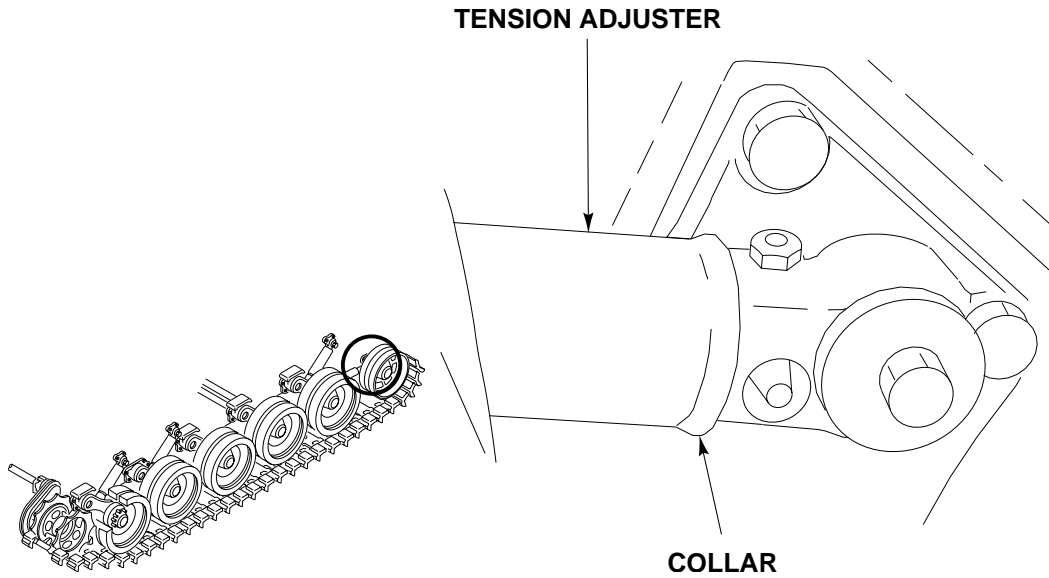

PREVENTIVE MAINTENANCE CHECKS AND SERVICES (PMCS), INCLUDING LUBRICATION INSTRUCTIONS — Continued

0155 00

ITEM NO.	INTERVAL	MAN-HOUR	ITEM TO BE CHECKED OR SERVICED	CREWMEMBER PROCEDURE	EQUIPMENT NOT READY/AVAILABLE IF:
12	Semi-Annual		Sprocket Mounting Screws	a. Check sprockets on both tracks for wear indicating that mounting bolts have come loose. Tighten loose bolts to 110-115 lb-ft (149-156 N·m) torque. Use torque wrench (WP 0926 00, Item 79). b. Check sprocket cushions for wear. Replace cushions if gouges, chips, or cuts cause thumping (T130 Track, see WP 0421 00) (T150 Track, see WP 0420 01).	Any bolts are missing, loose, or worn.

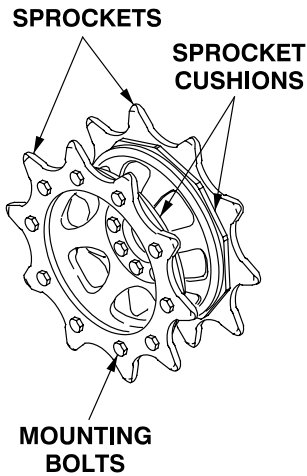

T130 TRACK

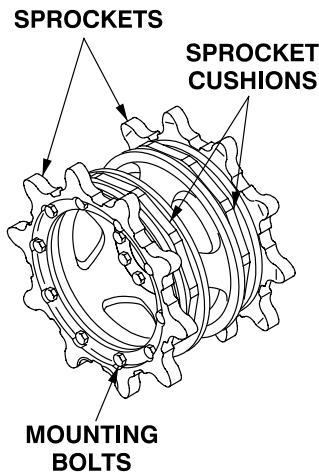

T150 TRACK

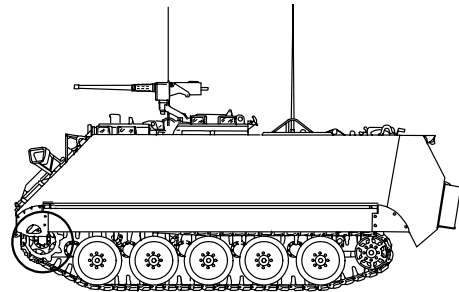

13

Semi-Annual

Sprocket Hub Bolts

a. Check sprocket hub bolts for looseness or missing bolts. Tighten loose bolts to 170-190 lb-ft (231-258 N·m) torque. Use torque wrench (WP 0926 00, Item 79). If bolts are missing, replace bolts (T130 Track, see WP 0420 00) (T150 Track, see WP 0420 01).

Any bolts are missing, loose, or worn.

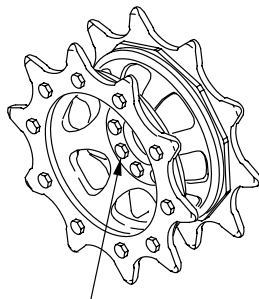

T130 TRACK

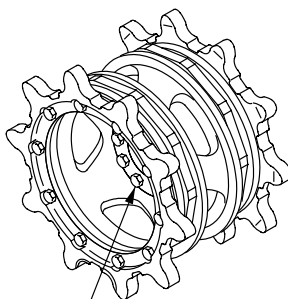

T150 TRACK

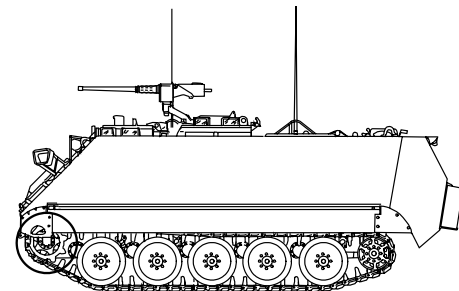

PREVENTIVE MAINTENANCE CHECKS AND SERVICES (PMCS), INCLUDING LUBRICATION INSTRUCTIONS — Continued

0155 00

ITEM NO.	INTERVAL	MAN-HOUR	ITEM TO BE CHECKED OR SERVICED	CREWMEMBER PROCEDURE	EQUIPMENT NOT READY/AVAILABLE IF:
13.1	1500		Track Assembly (T150 Track Only)	<p align="center">NOTE</p> <p>The T150 track assembly is to be reversed semi-annually. It needs to be reversed to put wear on the end connectors and track shoe bushings in both directions.</p> <p>a. The T150 track assembly needs to be reversed to put wear on the end connectors and track shoe bushings in both directions. This will extend the life of the track. If it is not reversed the track will wear unevenly and the life of the track will be reduced (WP 0419 01).</p> <p align="center">NOTE</p> <p>The end connector can only be checked with the track gauge when it is removed from the track shoe pins.</p> <p>b. Use the track gauge on the inside or facing side of the end connector toward the track shoe when it is removed. The track gauge slot is a no fit condition. If it does not fit, the end connector is still good for use. When the material on the end connector gets too thin and the track gauge fits, the end connector is bad and needs to be replaced with a new one.</p>	Any screws are missing, loose or worn.
14	Semi-Annual	0.5	Final Drive	<p>a. Tighten loose final drive-to-hull screws to 75-85 lb-ft (101-115 N·m) torque. Use torque wrench (WP 0926 00, Item 79).</p> <p align="center">NOTE</p> <p>Drain oil (3 1/2 quarts) only when hot after operation.</p>	

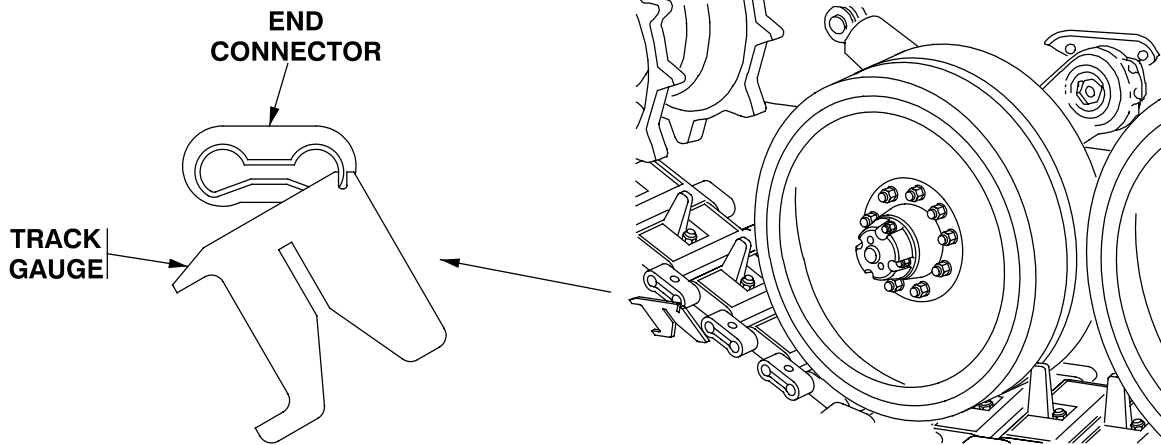

PREVENTIVE MAINTENANCE CHECKS AND SERVICES (PMCS), INCLUDING LUBRICATION INSTRUCTIONS — Continued

0155 00

ITEM NO.	INTERVAL	MAN-HOUR	ITEM TO BE CHECKED OR SERVICED	CREWMEMBER PROCEDURE	EQUIPMENT NOT READY/AVAILABLE IF:
				<p style="text-align: center;">NOTE</p> <p>Do not substitute hydraulic fluid for OE/HDO or OEA. Red dye has been added to some final drives to aid in detection of leaks.</p> <p>b. Drain final drives every 150 hours/1500 miles or semi-annually.</p> <ol style="list-style-type: none"> 1) Place a suitable container under final drive housing. 2) Remove drain plugs from final drive housing and drain oil into the container (WP 0452 00). 3) Inspect drain plugs and oil for metal particles. If metal chips are found, notify direct support maintenance. 4) Clean and install the drain plug (WP 0452 00). 5) Fill each final drive with OE/HDO or OEA, as applicable, to bring oil level to a point between the FULL and ADD marks on gauge rod. Each final drive holds approximately 3 1/2 quarts. See Final Drive Lubrication Table (Table 4, page 0155 00-19). 	<p>Oil is contaminated with metal chips or particles.</p>

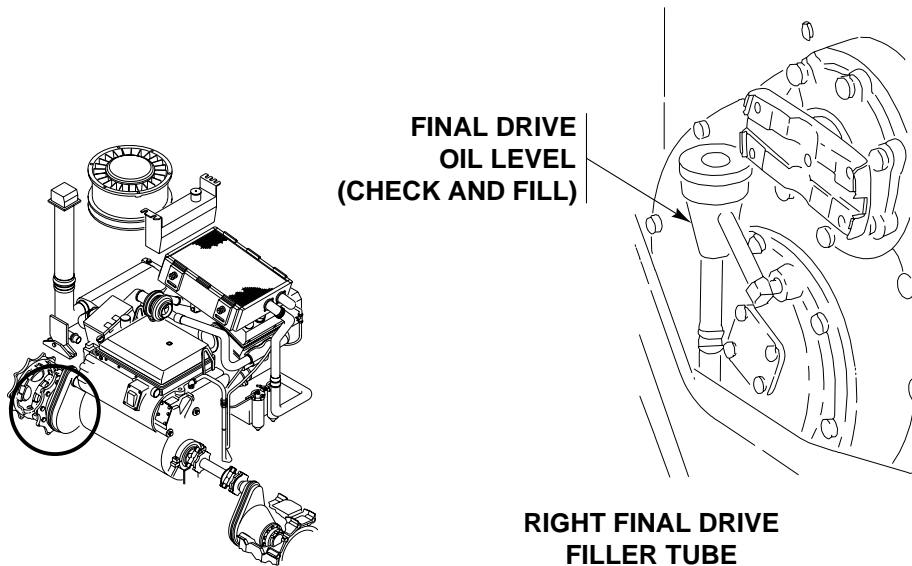

**PREVENTIVE MAINTENANCE CHECKS AND SERVICES (PMCS), INCLUDING
LUBRICATION INSTRUCTIONS — Continued**

0155 00

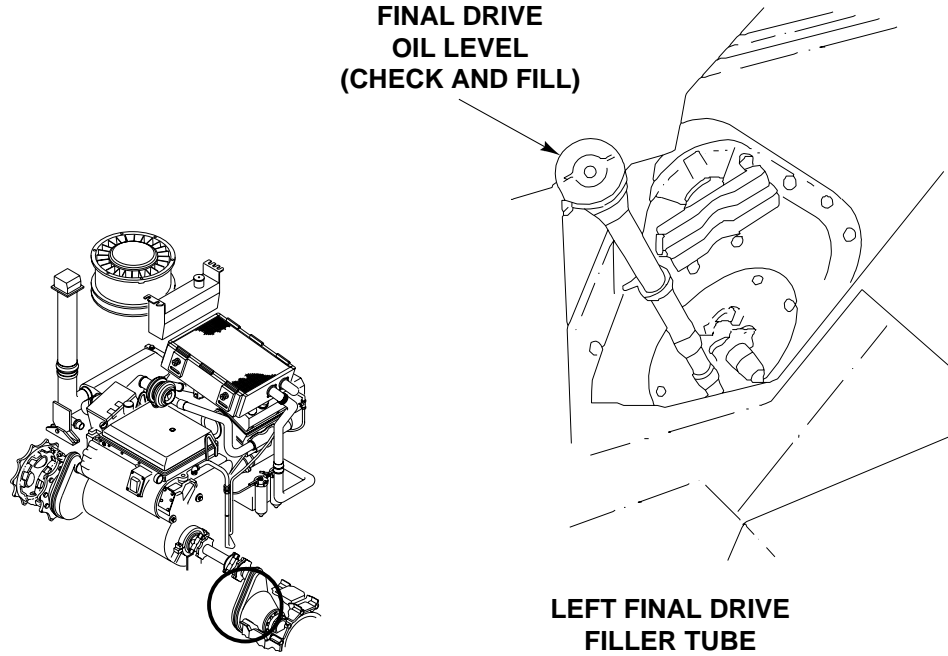
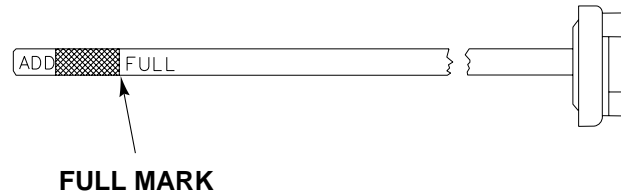
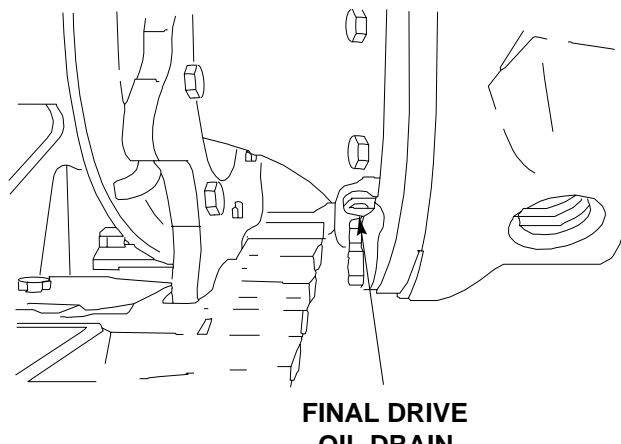
ITEM NO.	INTERVAL	MAN-HOUR	ITEM TO BE CHECKED OR SERVICED	CREWMEMBER PROCEDURE	EQUIPMENT NOT READY/AVAILABLE IF:
			<p>FINAL DRIVE OIL LEVEL (CHECK AND FILL)</p>  <p>LEFT FINAL DRIVE FILLER TUBE</p>	<p>FINAL DRIVE GAUGE ROD</p>  <p>FULL MARK</p>  <p>FINAL DRIVE OIL DRAIN</p>	

PREVENTIVE MAINTENANCE CHECKS AND SERVICES (PMCS), INCLUDING LUBRICATION INSTRUCTIONS — Continued

0155 00

ITEM NO.	INTERVAL	MAN-HOUR	ITEM TO BE CHECKED OR SERVICED	CREWMEMBER PROCEDURE	EQUIPMENT NOT READY/AVAILABLE IF:
15	Semi-Annual		Idler and Road Wheel Arms	<p>a. Replace cracked or bent idler or road wheel arms (WP 0415 00 or WP 0417 00). Replace idler or road wheel arm relief valves and grease fittings if leaking (WP 0415 00 or WP 0417 00). Replace leaking road wheel arms seals and gaskets (WP 0415 00).</p>	Any bent, broken or cracked arm or leaking seal.

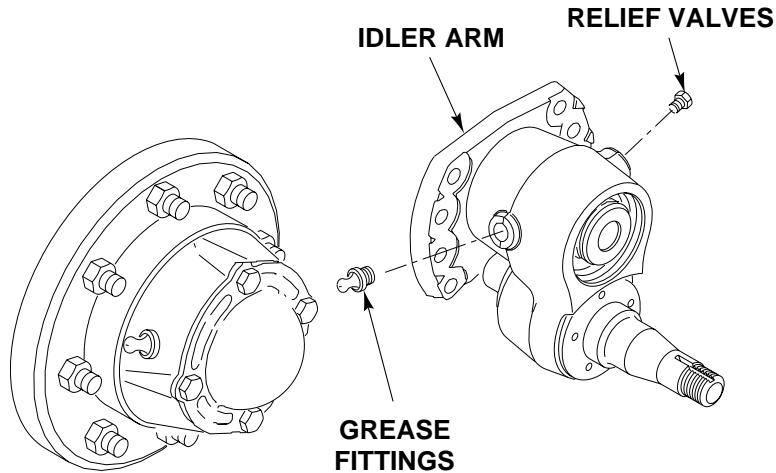
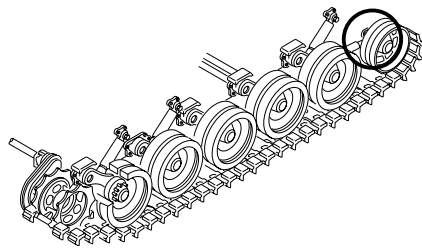

PREVENTIVE MAINTENANCE CHECKS AND SERVICES (PMCS), INCLUDING LUBRICATION INSTRUCTIONS — Continued

0155 00

ITEM NO.	INTERVAL	MAN-HOUR	ITEM TO BE CHECKED OR SERVICED	CREWMEMBER PROCEDURE	EQUIPMENT NOT READY/AVAILABLE IF:
16	Semi-Annual		Idler and Road Wheel Mounting Nuts	a. Check idler and road wheel mounting nuts for looseness. Tighten loose nuts to 150-170 lb-ft (203-230 N·m) torque. Use torque wrench (WP 0926 00, Item 79).	Any missing or stripped nuts.
17	Semi-Annual	1.4	Idler, Road Wheels, and Idler/Road Wheel Hubs	a. Replace cracked, broken or bent idler/road wheels and idler/road wheel hubs (WP 0415 00, WP 0416 00, WP 0417 00, and WP 0418 00). Refer to (WP 0416 00) for road wheel components. b. At each service, or wherever track is removed, adjust the wheel bearings if looseness or end play is observed (WP 0416 00, WP 0418 00). c. Replace leaking seals and gaskets (WP 0418 00). d. Replace grease fittings and relief valves if they are leaking (WP 0416 00, WP 0418 00).	Any broken, bent or cracked idler/road wheels or leaking hub seals. Number one or number five wheel-bearing loose. Leaky grease fittings.

PREVENTIVE MAINTENANCE CHECKS AND SERVICES (PMCS), INCLUDING LUBRICATION INSTRUCTIONS — Continued

0155 00

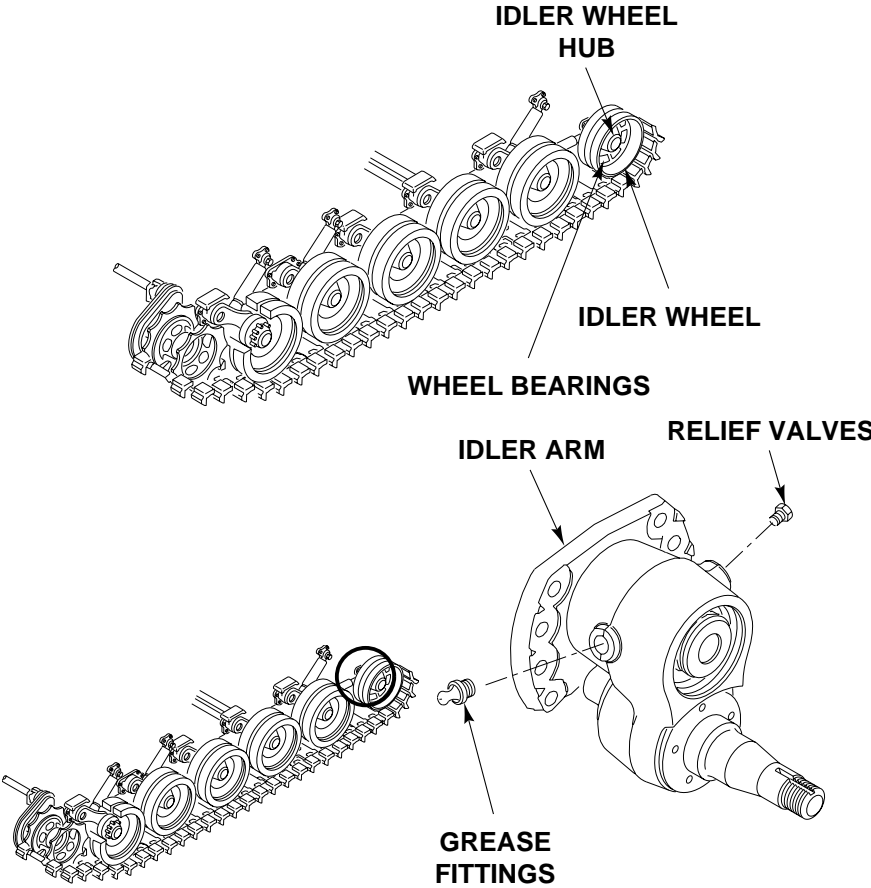
ITEM NO.	INTERVAL	MAN-HOUR	ITEM TO BE CHECKED OR SERVICED	CREWMEMBER PROCEDURE	EQUIPMENT NOT READY/ AVAILABLE IF:
				<p>e. Every 1500 miles or semi-annually, perform the following lubrication procedures. See Lubrication Table (Table 10, page 0155 00-25).</p> <p style="text-align: center;">NOTE</p> <p>When grease fitting will not accept GAA, notify your supervisor.</p> <ol style="list-style-type: none"> 1) Lubricate idler wheel support arm bearings through fittings. Use grease gun with GAA on fitting at rear of support arm until GAA appears at relief valve. 2) Lubricate road wheel and idler wheel hub bearings. Use GAA and grease gun with flexible adapter. Lubricate hub through fitting until grease appears at relief valve. 	

PREVENTIVE MAINTENANCE CHECKS AND SERVICES (PMCS), INCLUDING LUBRICATION INSTRUCTIONS — Continued

0155 00

ITEM NO.	INTERVAL	MAN-HOUR	ITEM TO BE CHECKED OR SERVICED	<u>CREWMEMBER</u> PROCEDURE	EQUIPMENT NOT READY/ AVAILABLE IF:
				<p>3) Lubricate all road wheel support arm bearings. Use GAA and grease gun with flexible adapter on fitting until GAA appears at relief valve. If support arm has plugs but no fittings, remove one plug and install fitting. Remove remaining plug and install relief valve. Perform lubrication. Remove fitting and relief valve. Clean and install two plugs.</p> <p>4) Clean fittings with cleaning compound (WP 0928 00, Item 19). Check/lubricate grease fitting points after washing or fording.</p>	

**IDLER WHEEL
SUPPORT ARM
BEARINGS**

PREVENTIVE MAINTENANCE CHECKS AND SERVICES (PMCS), INCLUDING LUBRICATION INSTRUCTIONS — Continued

0155 00

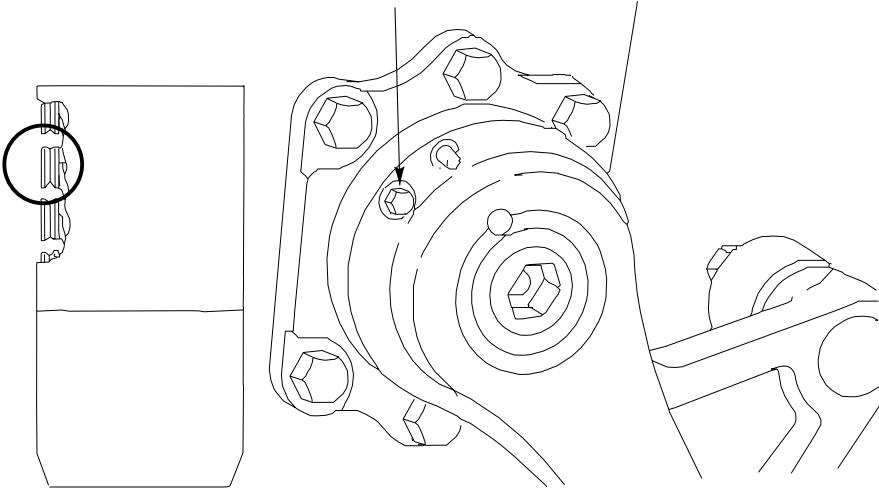
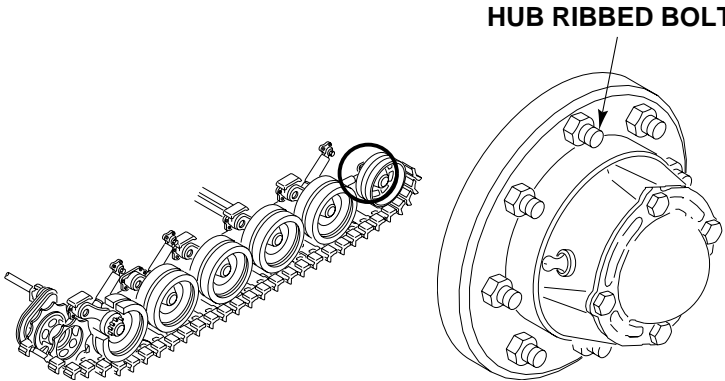
ITEM NO.	INTERVAL	MAN-HOUR	ITEM TO BE CHECKED OR SERVICED	CREWMEMBER PROCEDURE	EQUIPMENT NOT READY/AVAILABLE IF:
18	Semi-Annual		Idler and Road Wheel Hub Ribbed Bolts	<p style="text-align: center;">ROAD WHEEL SUPPORT ARM BEARINGS</p>  <p>a. Replace bent, broken or stripped idler or road wheel hub ribbed bolts (WP 0416 00, WP 0418 00). Refer to WP 0425 00 for idler components.</p> <p style="text-align: center;">HUB RIBBED BOLTS</p> 	Any broken, bent or stripped bolts.

PREVENTIVE MAINTENANCE CHECKS AND SERVICES (PMCS), INCLUDING LUBRICATION INSTRUCTIONS — Continued

0155 00

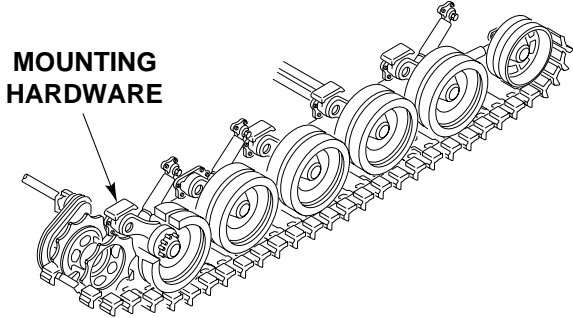
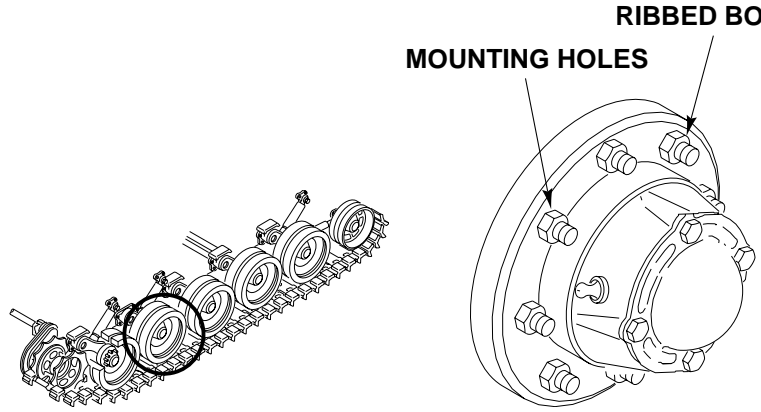
ITEM NO.	INTERVAL	MAN-HOUR	ITEM TO BE CHECKED OR SERVICED	CREWMEMBER PROCEDURE	EQUIPMENT NOT READY/AVAILABLE IF:
19	Semi-Annual		Road Wheel Arm Mounting Hardware	a. Tighten loose road wheel arm mounting hardware to 130-140 lb-ft (176-190 N·m) torque. Use torque wrench (WP 0926 00, Item 79).	Any loose mounting hardware.
 <p>MOUNTING HARDWARE</p>					
20	Semi-Annual		Road Wheel Mounting Holes	a. If road wheel mounting holes extend beyond head of mounting nut, replace road wheel (WP 0426 00).	Any elongated holes that extend beyond mounting nuts.
 <p>RIBBED BOLTS MOUNTING HOLES</p>					

**PREVENTIVE MAINTENANCE CHECKS AND SERVICES (PMCS), INCLUDING
LUBRICATION INSTRUCTIONS — Continued**

0155 00

ITEM NO.	INTERVAL	MAN-HOUR	ITEM TO BE CHECKED OR SERVICED	<u>CREWMEMBER</u> PROCEDURE	EQUIPMENT NOT READY/ AVAILABLE IF:
21	Semi-Annual		Torsion Bar Anchors/ Splines/End Plugs	a. Remove floor plates (see Table of Contents). b. Check plugs. Be sure they are fully seated. Tighten plugs to 50-75 lb-ft (68-102 N·m). Use torque wrench (WP 0926 00, Item 79).	Any broken, bent, missing, stripped torsion bars or attaching hardware.

PREVENTIVE MAINTENANCE CHECKS AND SERVICES (PMCS), INCLUDING LUBRICATION INSTRUCTIONS — Continued

0155 00

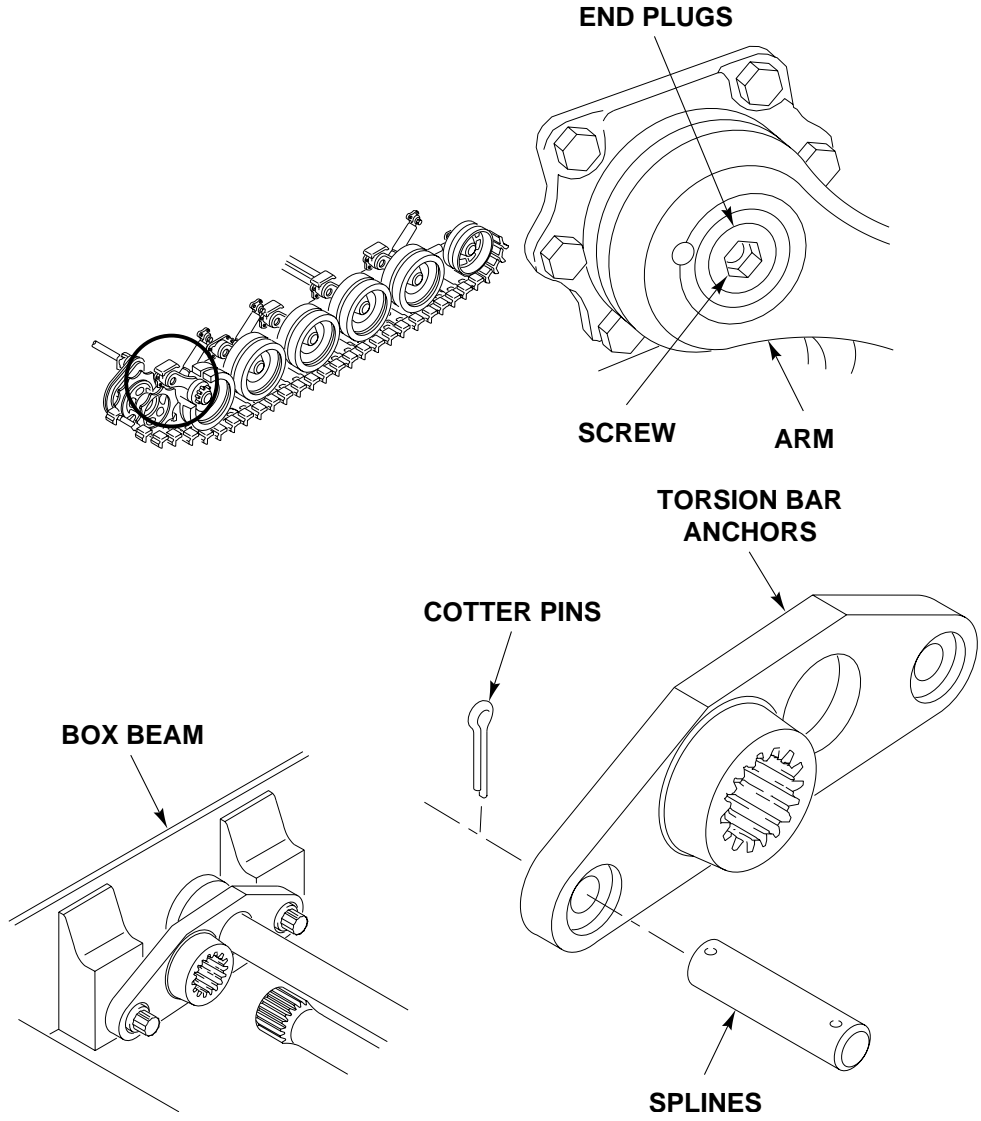
ITEM NO.	INTERVAL	MAN-HOUR	ITEM TO BE CHECKED OR SERVICED	CREWMEMBER PROCEDURE	EQUIPMENT NOT READY/AVAILABLE IF:
				<p>c. Replace missing or damaged cotter pins and pins or bolts from torsion bar anchors (WP 0414 00).</p>  <p>END PLUGS</p> <p>SCREW ARM</p> <p>TORSION BAR ANCHORS</p> <p>COTTER PINS</p> <p>BOX BEAM</p> <p>SPLINES</p>	
				<p>d. Coat ends of suspension torsion bar with GAA. See Lubrication Table (Table 10, page 0155 00-25).</p>	

PREVENTIVE MAINTENANCE CHECKS AND SERVICES (PMCS), INCLUDING LUBRICATION INSTRUCTIONS — Continued

0155 00

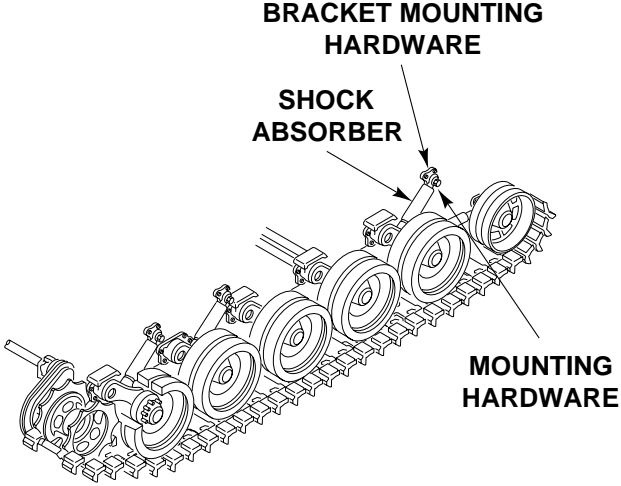
ITEM NO.	INTERVAL	MAN-HOUR	ITEM TO BE CHECKED OR SERVICED	CREWMEMBER PROCEDURE	EQUIPMENT NOT READY/ AVAILABLE IF:
22	Semi-Annual		Shock Absorber	<p>a. Check shock absorber for dents or cracks. Replace shock absorber that is bent, broken, cracked, or dented enough to hinder operation (WP 0435 00).</p> <p>b. Replace shock absorbers if they have Class III fluid leaks or loose fitting bearings (WP 0435 00).</p>	Any cracked, broken, bent, or missing shocks, dents that hinder shock operation, or Class III fluid leaks.
 <p>The diagram shows a side view of a shock absorber assembly. It consists of a central shock absorber cylinder connected to a bracket. The bracket is mounted on a track system with several rollers. Labels with arrows point to the 'BRACKET MOUNTING HARDWARE' at the top of the bracket, the 'SHOCK ABSORBER' in the center, and the 'MOUNTING HARDWARE' at the bottom where the bracket meets the track.</p>					
<p>NOTE</p> <p>Remove and discard cotter pin, re-torque if loose. Tighten to middle range of torque, check to see if nut and hole through mount are aligned, install new pin. If not aligned, tighten nut until alignment is first achieved and then install new cotter pin.</p>					
23	Semi-Annual		Shock Absorber Mounting Hardware	a. Check shock absorber mounting hardware for looseness. Tighten loose hardware to 60-80 lb-ft (81-108 N·m) torque. Use torque wrench (WP 0926 00, Item 85).	
24	Semi-Annual		Shock Absorber Bracket Mounting Hardware	a. Check shock absorber bracket mounting hardware for looseness. Tighten loose hardware to 130-140 lb-ft (176-190 N·m) torque. Use torque wrench (WP 0926 00, Item 85).	

PREVENTIVE MAINTENANCE CHECKS AND SERVICES (PMCS), INCLUDING LUBRICATION INSTRUCTIONS — Continued

0155 00

ITEM NO.	INTERVAL	MAN-HOUR	ITEM TO BE CHECKED OR SERVICED	<u>CREWMEMBER</u> PROCEDURE	EQUIPMENT NOT READY/ AVAILABLE IF:
25	Semi-Annual		Track Shroud	a. Check for torn shrouds. Replace torn shrouds. b. Tighten or replace loose or missing hardware. c. Repair bent shroud clamps.	

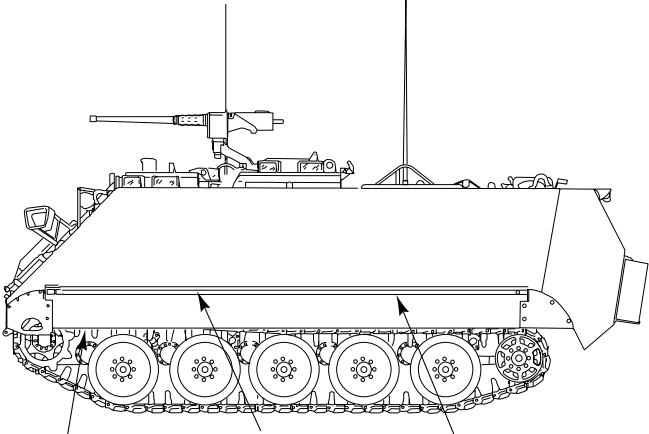

SHROUDS HARDWARE CLAMPS

PREVENTIVE MAINTENANCE CHECKS AND SERVICES (PMCS), INCLUDING LUBRICATION INSTRUCTIONS — Continued

0155 00

ITEM NO.	INTERVAL	MAN-HOUR	ITEM TO BE CHECKED OR SERVICED	<u>CREWMEMBER PROCEDURE</u>	EQUIPMENT NOT READY/AVAILABLE IF:
26	Semi-Annual		Fuel Filler Screen and Cap	<p>a. Check fuel filler screen for dirt buildup. If dirty, clean with cleaning compound (WP 0928 00, Item 19). Replace any screen that is damaged (WP 0184 00 and WP 0186 00). Attach or replace loose, broken, or missing keeper chain on filler cap.</p> <p style="text-align: center;">NOTE</p> <p>Only M1068A3 and M577A3 have a single fuel cap and filler screen.</p>	

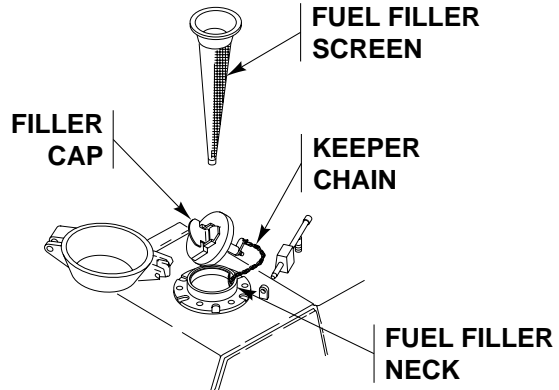
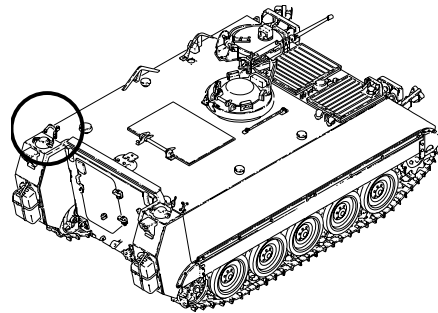

PREVENTIVE MAINTENANCE CHECKS AND SERVICES (PMCS), INCLUDING LUBRICATION INSTRUCTIONS — Continued

0155 00

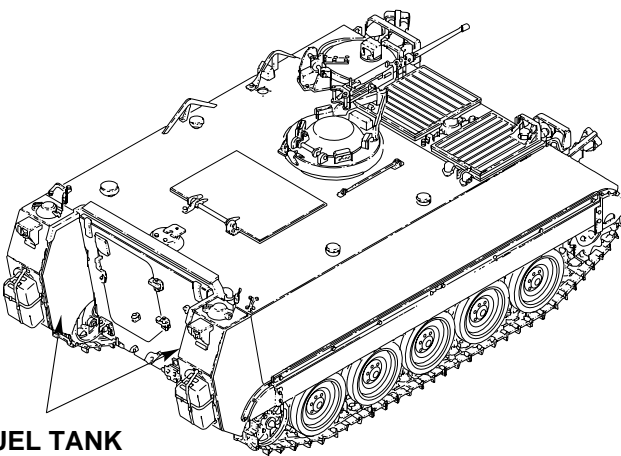
ITEM NO.	INTERVAL	MAN-HOUR	ITEM TO BE CHECKED OR SERVICED	<u>CREWMEMBER</u> PROCEDURE	EQUIPMENT NOT READY/ AVAILABLE IF:
27	Semi-Annual		Fuel Tanks	<p style="text-align: center;">WARNING</p> <div style="text-align: center;">  </div> <p>Fuel can catch fire and burn you. Disconnect battery ground lead (WP 0338 00) before you work on fuel system. Wipe up spilled fuel.</p> <p style="text-align: center;">CAUTION</p> <p>Don't expose sealed areas to steam for more than 15 minutes.</p> <p>a. Repair or replace any leaking tanks (WP 0179 00 or WP 0180 00).</p>	Contaminated fuel tank or fuel leak.
 <p>FUEL TANK</p>					

PREVENTIVE MAINTENANCE CHECKS AND SERVICES (PMCS), INCLUDING LUBRICATION INSTRUCTIONS — Continued

0155 00

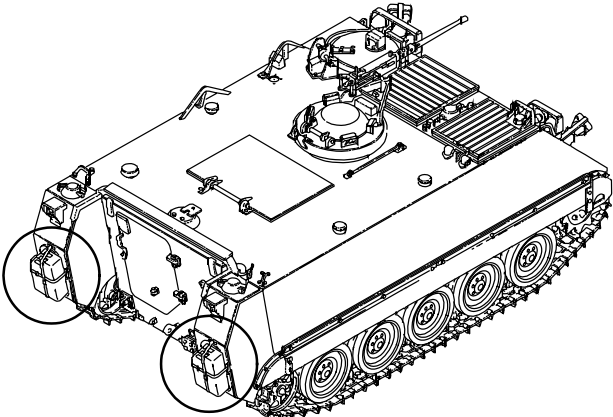
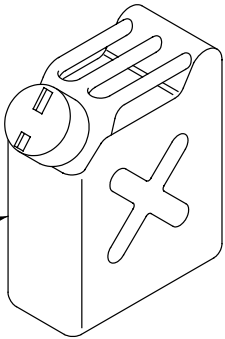
ITEM NO.	INTERVAL	MAN-HOUR	ITEM TO BE CHECKED OR SERVICED	CREWMEMBER PROCEDURE	EQUIPMENT NOT READY/AVAILABLE IF:
				<p style="text-align: center;">WARNING</p> <div style="text-align: center;">  </div> <p>Fuel can catch fire and burn you. Disconnect battery ground strap (WP 0337 00), (WP 0338 00) before you work on fuel system. Wipe up spilled fuel.</p> <p>b. M1059A3 Only Inspect tank and plug assembly for contamination. Clean as required. Check for leaks in fuel tank or fuel tank plug assembly. Repair leaky fuel tank plug (WP 0764 00) or replace leaky tank.</p>	
<div style="display: flex; justify-content: space-around; align-items: center;">  <div style="text-align: center;">  <p>FUEL CAN</p> </div> </div>					

PREVENTIVE MAINTENANCE CHECKS AND SERVICES (PMCS), INCLUDING LUBRICATION INSTRUCTIONS — Continued

0155 00

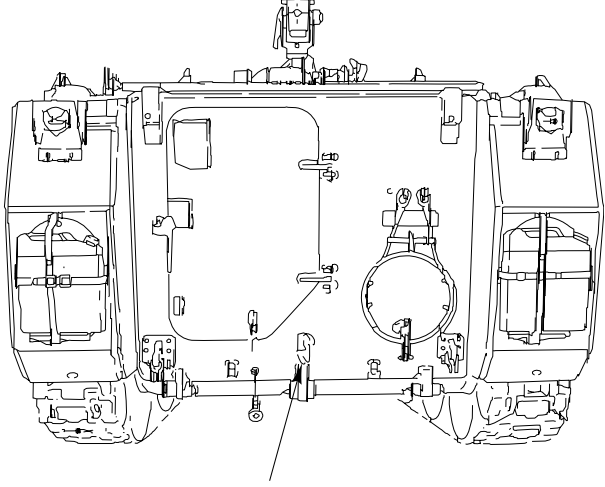
ITEM NO.	INTERVAL	MAN-HOUR	ITEM TO BE CHECKED OR SERVICED	<u>CREWMEMBER</u> PROCEDURE	EQUIPMENT NOT READY/ AVAILABLE IF:
28	Semi-Annual	0.1	Tow Hooks and Pintle	<p>a. Check pintle for proper operation (see your -10).</p> <div style="text-align: center;">  <p>PINTLE</p> </div> <p>b. Every 150 hours/1500 miles or semi-annually lubricate pintle. Late model pintles do not require lubrication.</p> <p style="text-align: center;">NOTE</p> <p>When grease fitting will not accept GAA, notify your supervisor.</p> <ol style="list-style-type: none"> 1) Lubricate pintle through two fittings with GAA. See Towing Pintle Lubrication Table (Table 9, page 0155 00-24). 2) Clean fittings with cleaning compound (WP 0928 00, Item 19) prior to lubrication. Check/lubricate grease fitting points after washing or fording. 	

PREVENTIVE MAINTENANCE CHECKS AND SERVICES (PMCS), INCLUDING LUBRICATION INSTRUCTIONS — Continued

0155 00

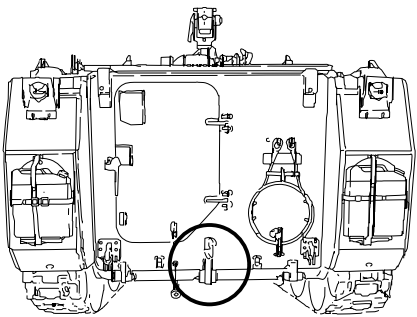
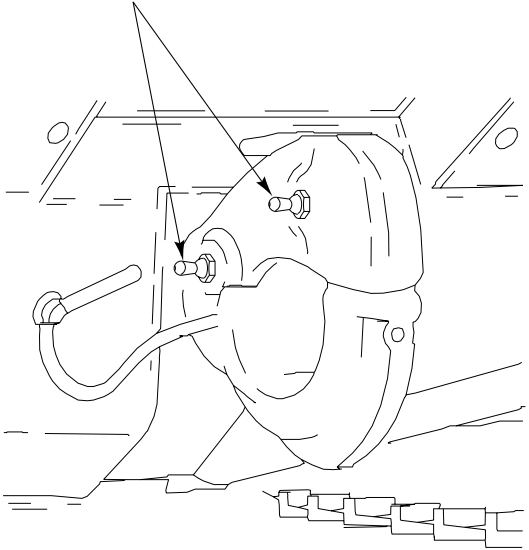
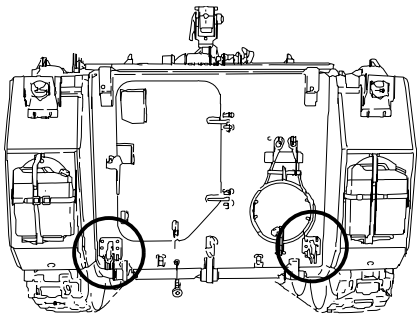
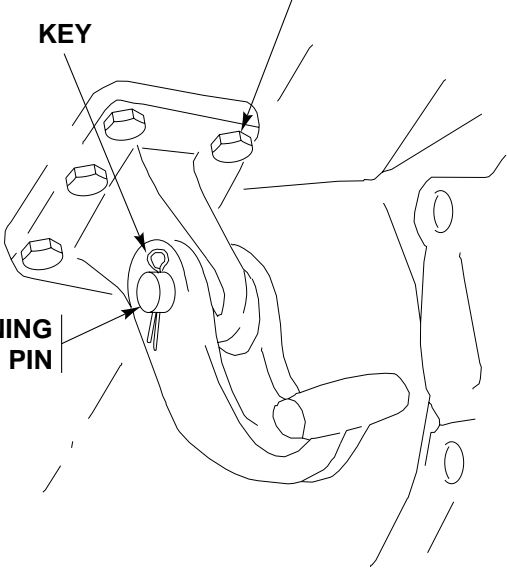
ITEM NO.	INTERVAL	MAN-HOUR	ITEM TO BE CHECKED OR SERVICED	CREWMEMBER PROCEDURE	EQUIPMENT NOT READY/AVAILABLE IF:
				<p style="text-align: center;">TOWING PINTLE (2 FITTINGS)</p>  <p>c. Check tow hook mount for looseness. Tighten loose screws to 130-140 lb-ft (176-190 N·m). Use torque wrench (WP 0926 00, Item 79).</p> <p>d. Replace missing retaining pin or key (WP 0434 00).</p>	
				<p style="text-align: center;">MOUNT SCREWS</p>  <p>KEY</p> <p>RETAINING PIN</p>	

PREVENTIVE MAINTENANCE CHECKS AND SERVICES (PMCS), INCLUDING LUBRICATION INSTRUCTIONS — Continued

0155 00

ITEM NO.	INTERVAL	MAN-HOUR	ITEM TO BE CHECKED OR SERVICED	<u>CREWMEMBER</u> PROCEDURE	EQUIPMENT NOT READY/ AVAILABLE IF:
29	Semi-Annual		Trailer Wiring Harness Receptacle Cover	a. Check cover for tight seal on wiring harness receptacle. Replace leaky cover (WP 0375 00).	

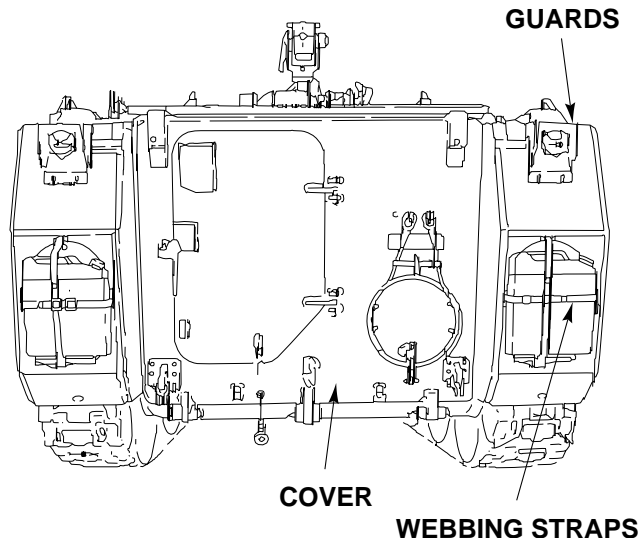

30	Semi-Annual		Rubber Guards	a. Replace cracked, cut, or hard guards (WP 0298 00).	
31	Semi-Annual		Webbing Straps and Loops	a. Replace cracked, cut or frayed webbing straps and loops, both external and internal (WP 0569 00).	

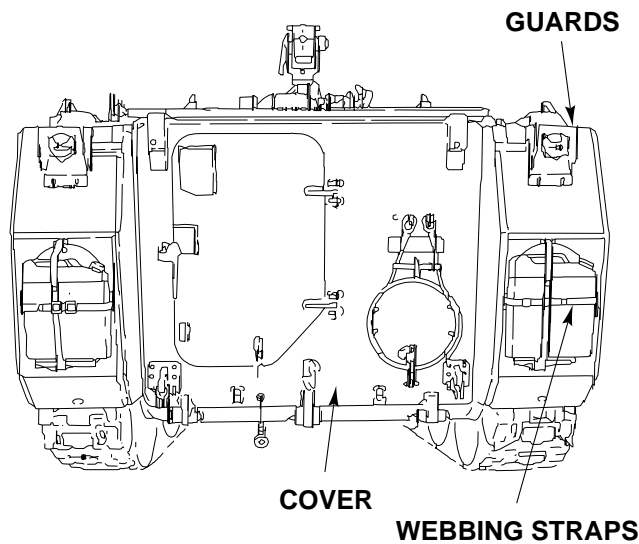

PREVENTIVE MAINTENANCE CHECKS AND SERVICES (PMCS), INCLUDING LUBRICATION INSTRUCTIONS — Continued

0155 00

ITEM NO.	INTERVAL	MAN-HOUR	ITEM TO BE CHECKED OR SERVICED	<u>CREWMEMBER</u> PROCEDURE	EQUIPMENT NOT READY/ AVAILABLE IF:
32	Semi-Annual		Tail Lights, Stop Lights, and Blackout Lights	a. Replace discolored and cracked tail light lens (WP 0300 00 or WP 0302 00). b. Have helper operate service tail light, service stop light, blackout stop light (see your -10). Repair lights that do not work (WP 0305 00) or replace lights that do not work (WP 0306 00).	

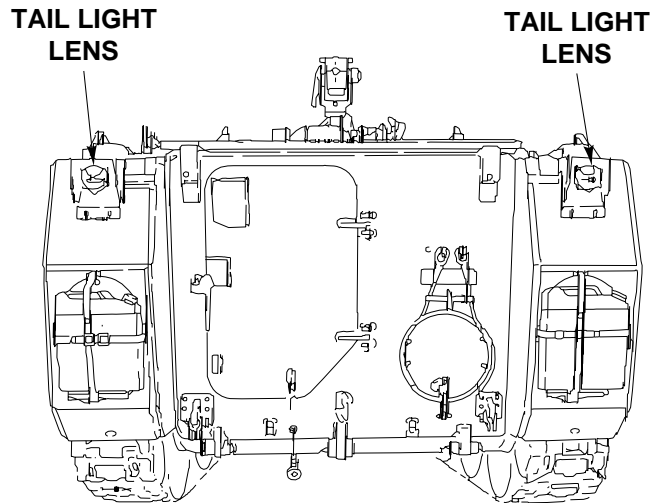

PREVENTIVE MAINTENANCE CHECKS AND SERVICES (PMCS), INCLUDING LUBRICATION INSTRUCTIONS — Continued

0155 00

ITEM NO.	INTERVAL	MAN-HOUR	ITEM TO BE CHECKED OR SERVICED	<u>CREWMEMBER</u> PROCEDURE	EQUIPMENT NOT READY/ AVAILABLE IF:
33	Semi-Annual		Ramp Door, Seal and Catch	<p align="center">NOTE</p> <p>See (Step 5c) under General Maintenance Instructions to perform chalk test.</p> <p>a. Perform chalk test. Replace leaky ramp door seal (WP 0520 00).</p> <p>b. Check door for smooth operation. If hinges bind, notify your supervisor. Repair catch if door does not lock in open position (WP 0524 00).</p> <p>c. Adjust handle if door does not seal tightly in closed position (WP 0519 00).</p>	Doors fail to lock in any position.

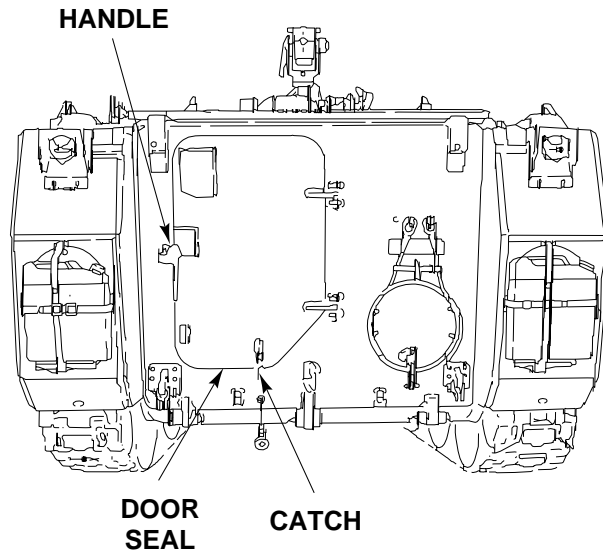

PREVENTIVE MAINTENANCE CHECKS AND SERVICES (PMCS), INCLUDING LUBRICATION INSTRUCTIONS — Continued

0155 00

ITEM NO.	INTERVAL	MAN-HOUR	ITEM TO BE CHECKED OR SERVICED	<u>CREWMEMBER</u> PROCEDURE	EQUIPMENT NOT READY/ AVAILABLE IF:
34	Semi-Annual		Ramp Latches, Seals and Wire Rope	<p style="text-align: center;">WARNING</p>  <p>Lowering ramp could injure personnel. Make sure no one is in ramp zone before you lower ramp. Unlocked ramp can fall open suddenly. Personnel can be killed or injured. Ramp system and hull can get damaged if ramp unlocks when carrier is in operation. Do not operate carrier if locks do not secure ramp properly. Keep away from ramps that have come open during carrier operation.</p> <p>a. With ramp closed, check for tight fit on rear seal. Adjust ramp lock (WP 0521 00, WP 0522 00, WP 0523 00) and linkage (WP 0527 00, WP 0528 00) if needed.</p>	Damage which allows ramp to free fall or wire rope is frayed or broken.

PREVENTIVE MAINTENANCE CHECKS AND SERVICES (PMCS), INCLUDING LUBRICATION INSTRUCTIONS — Continued

0155 00

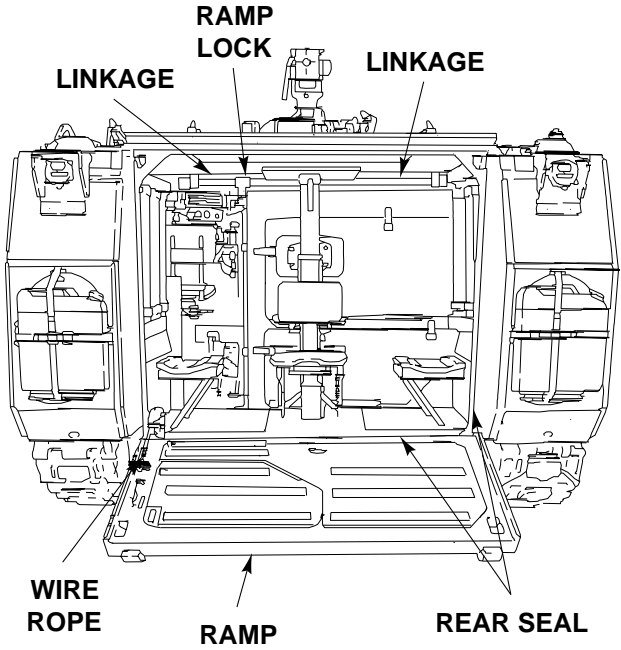
ITEM NO.	INTERVAL	MAN-HOUR	ITEM TO BE CHECKED OR SERVICED	<u>CREWMEMBER</u> PROCEDURE	EQUIPMENT NOT READY/ AVAILABLE IF:
35	Semi-Annual		Head-lights, Blackout Lights and Horn	<p style="text-align: center;">NOTE</p> <p>Horn should be sounded before raising ramp, if tactical situation permits.</p> <p>b. Replace ramp seal that is cut, cracked, or hard (WP 0514 00).</p> <p>c. Replace wire rope that is frayed or has broken strands (WP 0657 00, WP 0658 00).</p>	
				<div style="text-align: center;">  </div> <p>a. Replace cracked or discolored lens in service headlights, infrared headlights, blackout marker lights or blackout headlight (WP 0303 00, WP 0304 00, WP 0305 00, WP 0307 00).</p>	

PREVENTIVE MAINTENANCE CHECKS AND SERVICES (PMCS), INCLUDING LUBRICATION INSTRUCTIONS — Continued

0155 00

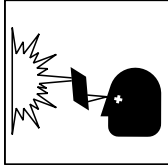
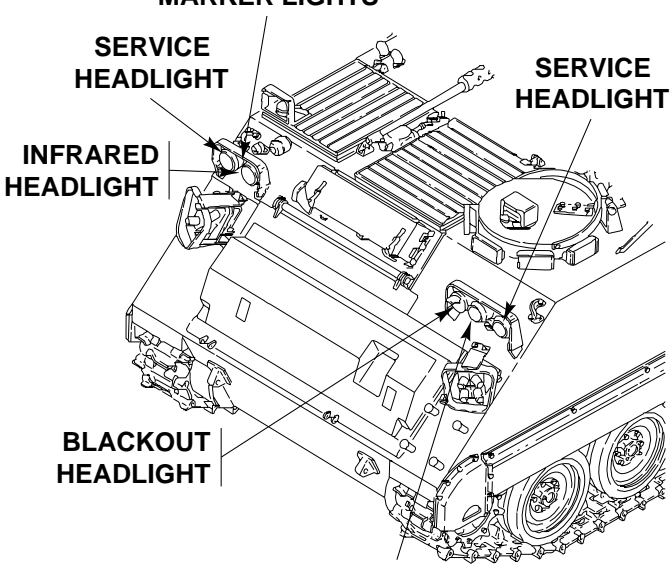
ITEM NO.	INTERVAL	MAN-HOUR	ITEM TO BE CHECKED OR SERVICED	CREWMEMBER PROCEDURE	EQUIPMENT NOT READY/ AVAILABLE IF:
				<p style="text-align: center;">WARNING</p> <div style="text-align: center;">  </div> <p>Looking directly at infrared headlights may burn your eyes. Do not look directly into infrared headlight.</p> <p>b. Have assistant operate service headlights and infrared headlights, feeling for heat. Operate blackout marker lights, blackout headlight and horn. Repair or replace lights or horn that do not work (WP 0303 00, WP 0304 00, WP 0305 00, WP 0307 00, WP 0336 00).</p>	
<div style="display: flex; justify-content: center; align-items: center;"> <div style="text-align: center; margin-right: 20px;"> <p>BLACKOUT MARKER LIGHTS</p>  </div> </div>					

**PREVENTIVE MAINTENANCE CHECKS AND SERVICES (PMCS), INCLUDING
LUBRICATION INSTRUCTIONS — Continued**

0155 00

ITEM NO.	INTERVAL	MAN-HOUR	ITEM TO BE CHECKED OR SERVICED	<u>CREWMEMBER</u> PROCEDURE	EQUIPMENT NOT READY/ AVAILABLE IF:
36	Semi-Annual		Remove Smoke Grenade Discharger (if installed) (all except M577A3, M1068A3, and M1064A3)	<ul style="list-style-type: none"> a. Remove base from front hull plate (WP 0455 00). b. Check wiring harness. Replace cracked or broken leads and connectors (WP 0455 00). c. Check guard, plate and base. Replace damaged parts. Tighten loose screws and nuts. d. Install base on front hull plate (WP 0455 00). e. Repeat Steps 36a. - 36d. for opposite side of carrier. 	

PREVENTIVE MAINTENANCE CHECKS AND SERVICES (PMCS), INCLUDING LUBRICATION INSTRUCTIONS — Continued

0155 00

ITEM NO.	INTERVAL	MAN-HOUR	ITEM TO BE CHECKED OR SERVICED	<u>CREWMEMBER</u> PROCEDURE	EQUIPMENT NOT READY/ AVAILABLE IF:
37	Semi-Annual		Trim Vane	a. Replace gouged or hard trim vane bumpers (WP 0458 00). b. Replace or repair warped or badly damaged trim vane (WP 0459 00, WP 0460 00). c. Check release mechanism and control linkage for proper operation. Replace weak springs and broken parts (WP 0462 00).	

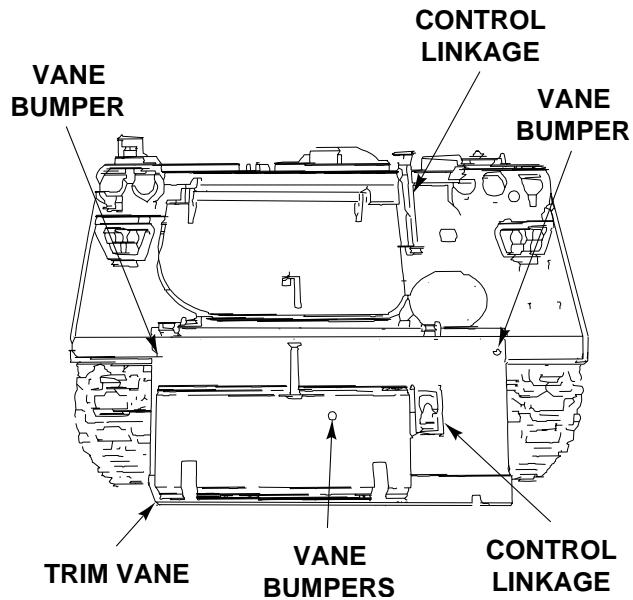

**PREVENTIVE MAINTENANCE CHECKS AND SERVICES (PMCS), INCLUDING
LUBRICATION INSTRUCTIONS — Continued**

0155 00

ITEM NO.	INTERVAL	MAN-HOUR	ITEM TO BE CHECKED OR SERVICED	<u>CREWMEMBER</u> PROCEDURE	EQUIPMENT NOT READY/ AVAILABLE IF:
38	Semi-Annual		Power Plant Grille and Power Plant Front Access Door	<p>a. Check screws on power plant grille for looseness. Tighten loose screws to 100-120 lb-ft (136–163 N·m) torque. Use torque wrench (WP 0926 00, Item 79).</p> <div style="text-align: center;"> <p>WARNING</p>  <p>Power plant door may spring open. When opening door, stay out of door path. Soldiers can be injured.</p> </div> <p>b. Check power plant front access door seal for cracks, cuts, stiffness, and looseness. If seal is loose, tighten. If seal is damaged, replace (WP 0472 00).</p>	Damage prevents door from closing, sealing and locking.

PREVENTIVE MAINTENANCE CHECKS AND SERVICES (PMCS), INCLUDING LUBRICATION INSTRUCTIONS — Continued

0155 00

ITEM NO.	INTERVAL	MAN-HOUR	ITEM TO BE CHECKED OR SERVICED	CREWMEMBER PROCEDURE	EQUIPMENT NOT READY/ AVAILABLE IF:
				<p style="text-align: center;">NOTE</p> <p>See (Step 5c) under General Maintenance Instructions to perform chalk test.</p> <p>c. Check for tight seal on door in closed position. Perform chalk test.</p>	

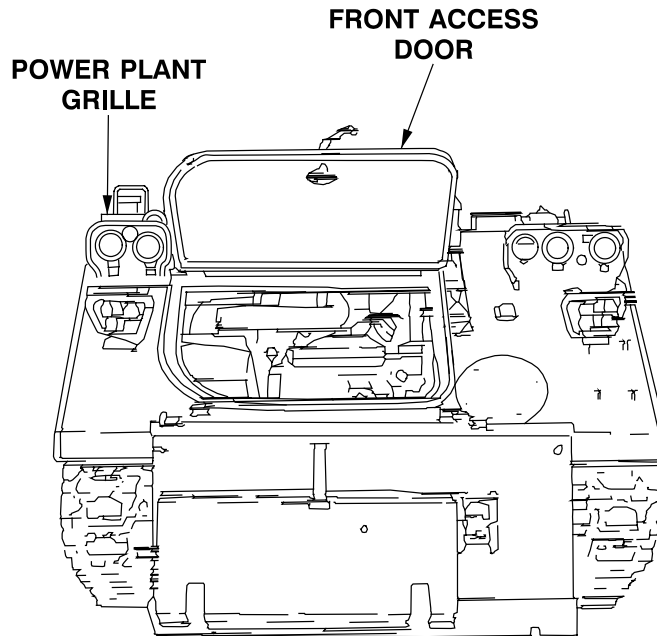

PREVENTIVE MAINTENANCE CHECKS AND SERVICES (PMCS), INCLUDING LUBRICATION INSTRUCTIONS — Continued

0155 00

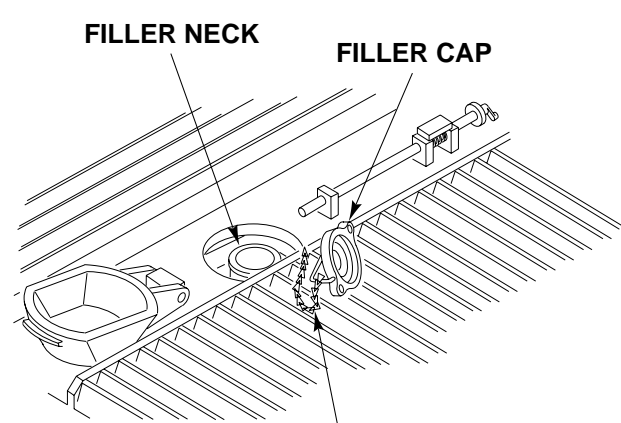
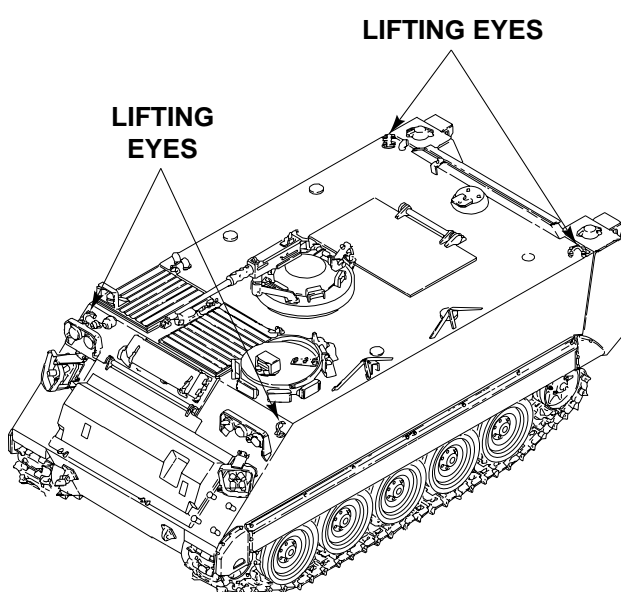
ITEM NO.	INTERVAL	MAN-HOUR	ITEM TO BE CHECKED OR SERVICED	CREWMEMBER PROCEDURE	EQUIPMENT NOT READY/AVAILABLE IF:
39	Semi-Annual		Radiator Auxiliary Tank Filler Cap	<p>a. Replace filler cap that does not seal tightly on auxiliary tank filler neck (WP 0227 00).</p> <p>b. Attach or replace loose, broken or missing keeper chain on filler cap (WP 0227 00).</p>	Any class III coolant leaks.
					
40	Semi-Annual		Lifting Eyes	<p>a. Check for loose or missing screws on lifting eyes. Replace missing screws. Tighten loose screws to 175-200 lb-ft (237-271 N·m). Use torque wrench (WP 0926 00, Item 80).</p>	
					

PREVENTIVE MAINTENANCE CHECKS AND SERVICES (PMCS), INCLUDING LUBRICATION INSTRUCTIONS — Continued

0155 00

ITEM NO.	INTERVAL	MAN-HOUR	ITEM TO BE CHECKED OR SERVICED	CREWMEMBER PROCEDURE	EQUIPMENT NOT READY/ AVAILABLE IF:
41	Semi-Annual		Hatch Covers, Latches and Seals	<p>a. Replace cracked, cut, or hard seal (WP 0478 00).</p> <p>b. Check covers for smooth operation. Repair or lubricate cover that binds. Repair catch if cover doesn't lock in open position.</p> <p>c. Replace damaged or missing catch safety pins.</p> <p>d. Replace bumpers that are cut, gouged, or hard.</p> <p>e. Adjust bumpers that do not compress when covers are locked open (see your -10).</p>	Hatch fails to lock in any position or catch safety pin is missing.
<p>A technical line drawing of a hatch assembly. It shows a circular hatch cover being lifted from its base. Labels with arrows point to various components: 'SEAL' on the top edge of the cover, 'COVER' for the top surface, 'BUMPERS' at the bottom edge of the cover, 'CATCH' and 'SAFETY PINS' at the base of the hatch mechanism.</p>					
42	Semi-Annual		Machine Gun Mount	<p>a. Check for loose or missing screws on machine gun mount. Replace missing screws.</p>	Mount is cracked or broken.
<p>A technical line drawing of a tracked vehicle chassis. A machine gun mount is mounted on the top deck. A label 'MACHINE GUN MOUNT' with an arrow points to the central mounting structure. The drawing shows the tracks, sprockets, and various mechanical details of the vehicle's hull.</p>					

PREVENTIVE MAINTENANCE CHECKS AND SERVICES (PMCS), INCLUDING LUBRICATION INSTRUCTIONS — Continued

0155 00

ITEM NO.	INTERVAL	MAN-HOUR	ITEM TO BE CHECKED OR SERVICED	<u>CREWMEMBER</u> PROCEDURE	EQUIPMENT NOT READY/ AVAILABLE IF:
43	Semi-Annual		Power Plant Bottom Access Cover, Hull Drain Plugs, and Final Drive Drain Plugs	<p>a. Check final drive drain plugs for leaks. Tighten leaking plugs (WP 0452 00).</p> <p>b. Check for loose or missing hull drain plugs. If missing, replace hull drain plug. Tighten loose plugs (WP 0451 00).</p> <p>c. Remove power plant bottom access cover and check for missing or damaged seal. Replace missing or damaged seal. Install bottom access cover. Tighten screws to 40-50 lb-ft (54-68 N·m) torque. Use torque wrench (WP 0926 00, Item 79).</p> <p>d. Check for loose or missing screws in power plant bottom access cover. Replace screws if missing. Tighten loose screws to 40-50 lb-ft (54-68 N·m) torque. Use torque wrench (WP 0926 00, Item 79).</p>	<p>Any Class III leaks or missing seals, covers or plugs.</p> <p>Missing or loose seals, plugs or covers.</p>

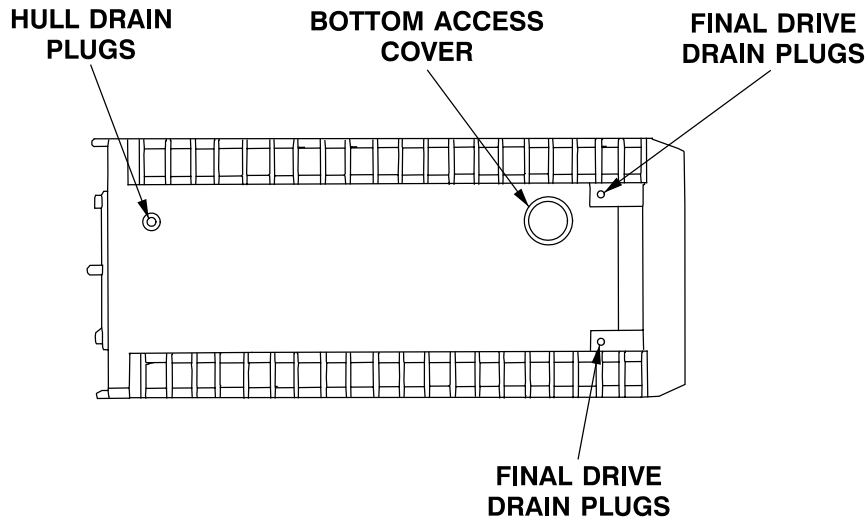

PREVENTIVE MAINTENANCE CHECKS AND SERVICES (PMCS), INCLUDING LUBRICATION INSTRUCTIONS — Continued

0155 00

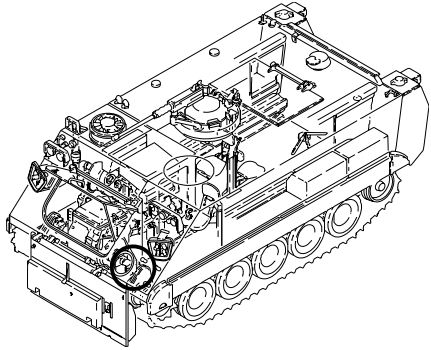
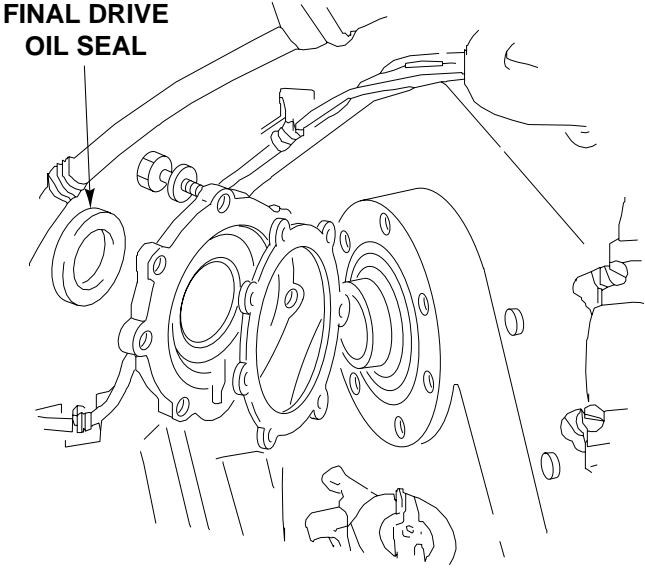
ITEM NO.	INTERVAL	MAN-HOUR	ITEM TO BE CHECKED OR SERVICED	CREWMEMBER PROCEDURE	EQUIPMENT NOT READY/ AVAILABLE IF:
44	Semi-Annual		Final Drive	<p>a. Inspect final drive input shaft oil seals for evidence of leakage. Replace final drive seals that have leaks (WP 0404 00). Tighten screws to 21-25 lb-ft (28-34 N·m) torque. Use torque wrench (WP 0926 00, Item 79).</p>	Any Class III leaks.
					
45	Semi-Annual		Power Plant Noises	<p>a. Check power plant operation. If unusual noises are heard, repair suspect component or contact higher level of maintenance for assistance and repair.</p>	
46	Semi-Annual		Exhaust System	<p style="text-align: center;">NOTE</p> <p>Carrier leaks exhaust when weather is cold. For this reason, carbon will be present around joints and exhaust pipe connecting clamps. This is normal. The exhaust system joints will seal after pipes heat up. Check for exhaust leaks only after engine reaches normal operating temperature of 180° to 205°F (71° to 93.3 °C).</p>	

PREVENTIVE MAINTENANCE CHECKS AND SERVICES (PMCS), INCLUDING LUBRICATION INSTRUCTIONS — Continued

0155 00

ITEM NO.	INTERVAL	MAN-HOUR	ITEM TO BE CHECKED OR SERVICED	<u>CREWMEMBER</u> PROCEDURE	EQUIPMENT NOT READY/ AVAILABLE IF:
				a. Check manifold, pipes, muffler, and clamps for looseness or damage. Replace damaged hardware. Tighten loose clamps.	Missing or damaged hardware allowing exhaust leaks.

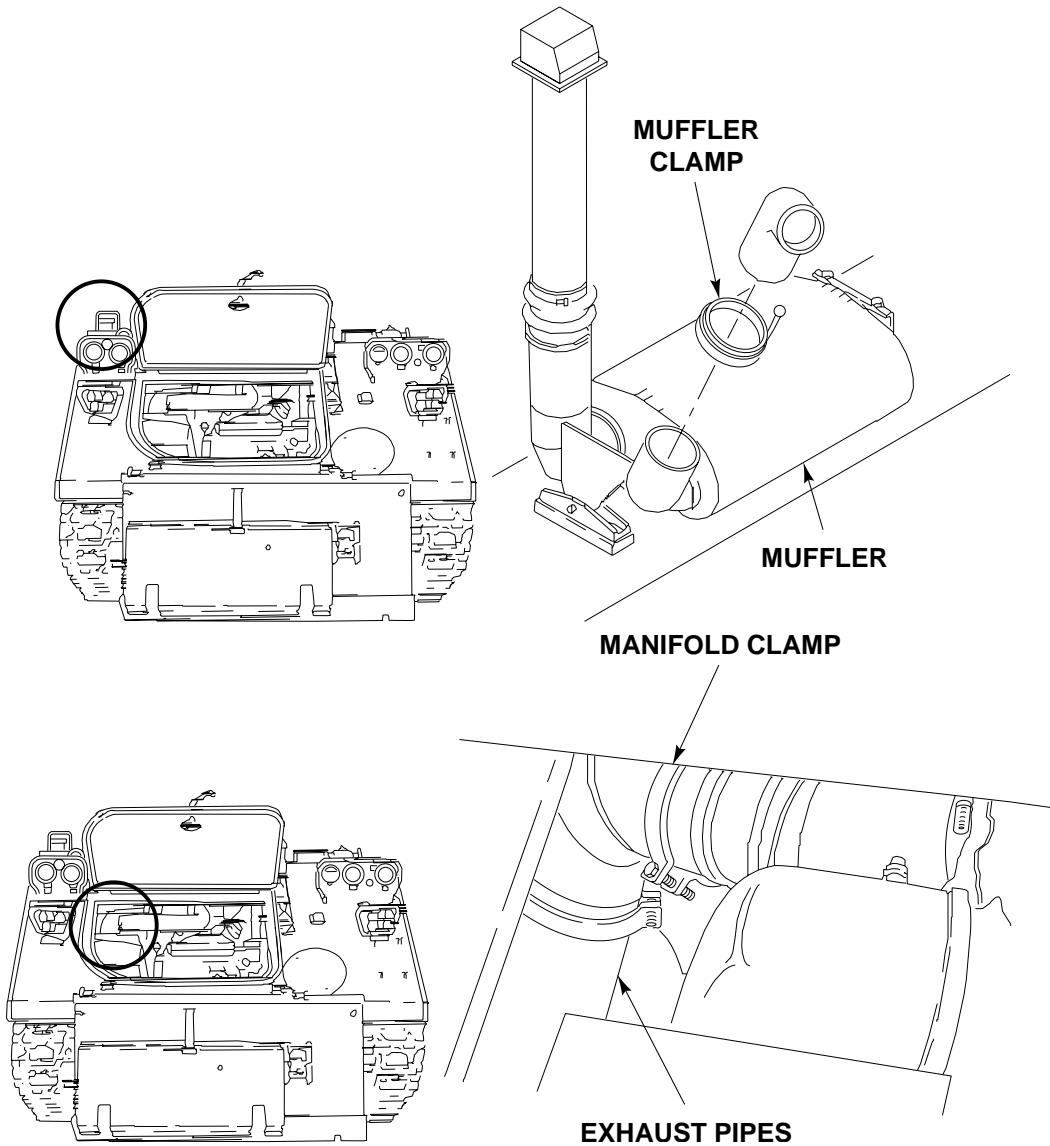

PREVENTIVE MAINTENANCE CHECKS AND SERVICES (PMCS), INCLUDING LUBRICATION INSTRUCTIONS — Continued

0155 00

ITEM NO.	INTERVAL	MAN-HOUR	ITEM TO BE CHECKED OR SERVICED	<u>CREWMEMBER</u> PROCEDURE	EQUIPMENT NOT READY/ AVAILABLE IF:
47	Semi-Annual		Air Cleaner	a. Clean or replace air cleaner element (WP 0167 00). b. Clean drain hole on bottom of air cleaner container. Replace damaged container (WP 0167 00).	Latches or element is missing, damaged or broken. Gasket is torn or separated from element.

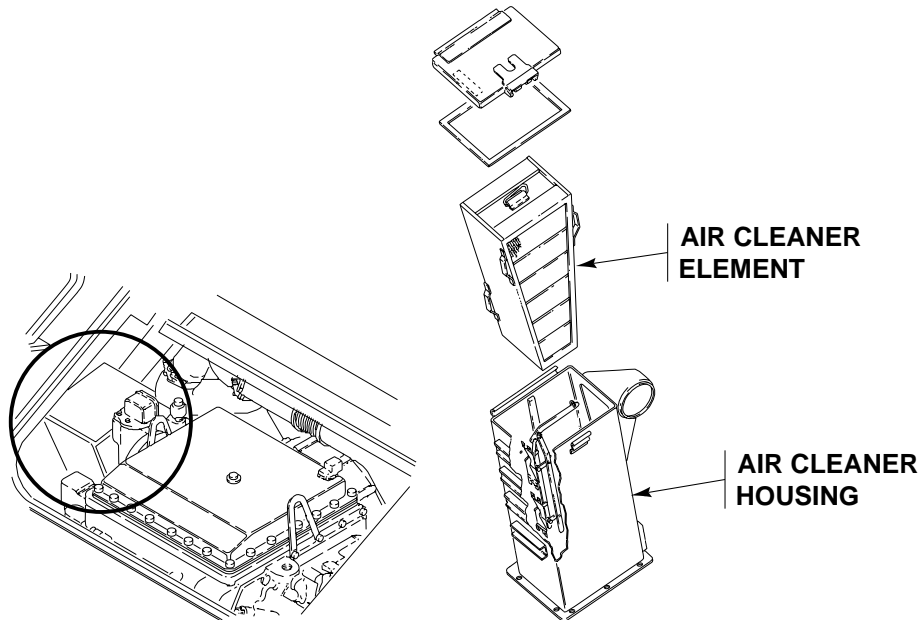

PREVENTIVE MAINTENANCE CHECKS AND SERVICES (PMCS), INCLUDING LUBRICATION INSTRUCTIONS — Continued

0155 00

ITEM NO.	INTERVAL	MAN-HOUR	ITEM TO BE CHECKED OR SERVICED	CREWMEMBER PROCEDURE	EQUIPMENT NOT READY/AVAILABLE IF:
48	Semi-Annual		Air Cleaner Hoses	a. Replace cracked, broken, or brittle hoses (WP 0172 00).	

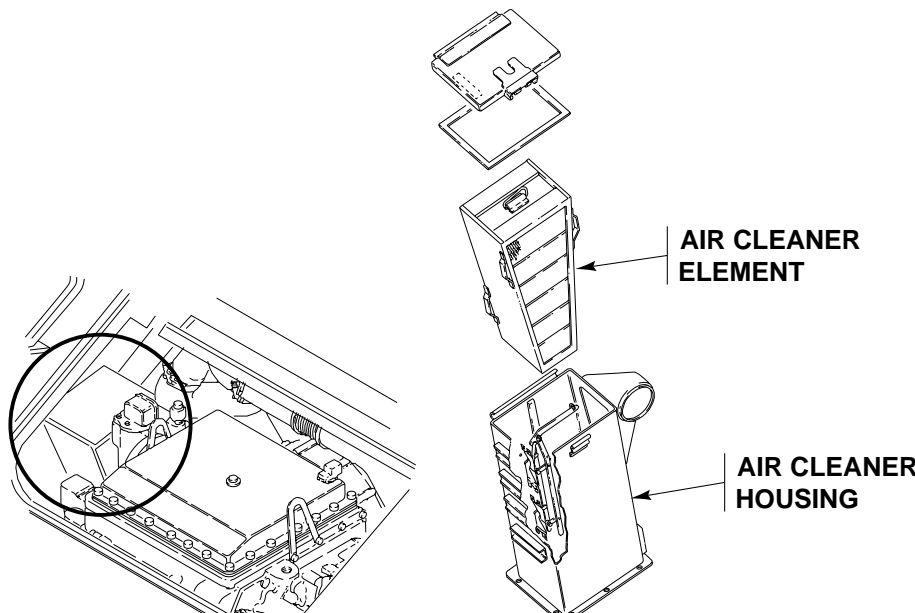

PREVENTIVE MAINTENANCE CHECKS AND SERVICES (PMCS), INCLUDING LUBRICATION INSTRUCTIONS — Continued

0155 00

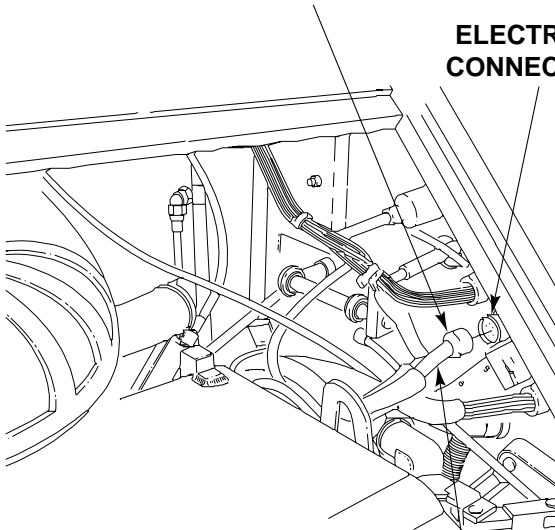
ITEM NO.	INTERVAL	MAN-HOUR	ITEM TO BE CHECKED OR SERVICED	CREWMEMBER PROCEDURE	EQUIPMENT NOT READY/ AVAILABLE IF:
49	Semi-Annual		Electrical Connectors and Leads	<p>a. Check electrical connectors for looseness or broken contact. Replace broken connectors (WP 0382 00).</p> <p>b. Check that electrical leads in power plant compartment are not frayed, cut, or broken. If leads are damaged, identify damaged lead. Go to the Table of Contents for electrical lead/harness connectors repairs and locate the specific task to repair or replace the damaged lead or wiring harness.</p>	
<p>ELECTRICAL CONNECTORS</p>  <p>ELECTRICAL LEADS</p>					
50	Semi-Annual	0.5	Drive Shafts and Universal Joints	<p style="text-align: center;">NOTE</p> <p>See Step 1g under General Maintenance Instructions for proper use of torque wrench adapter.</p> <p>a. Check for loose or missing screws and lockwashers on universal joints. Tighten loose screws to 86-92 lb-ft (117-127 N·m) torque. Use torque wrench (WP 0926 00, Item 79) and adapter (WP 0926 00, Item 4).</p>	Any hardware is loose, broken, or missing.

PREVENTIVE MAINTENANCE CHECKS AND SERVICES (PMCS), INCLUDING LUBRICATION INSTRUCTIONS — Continued

0155 00

ITEM NO.	INTERVAL	MAN-HOUR	ITEM TO BE CHECKED OR SERVICED	CREWMEMBER PROCEDURE	EQUIPMENT NOT READY/ AVAILABLE IF:
				<p>b. Every 1500 miles or semi-annually, lubricate U-joints.</p> <p style="text-align: center;">NOTE</p> <p>If the universal joint does not have grease fittings, it is a permanent lubed universal joint and does not require lubrication.</p> <p style="text-align: center;">NOTE</p> <p>When grease fitting will not accept GAA, notify your supervisor.</p> <ol style="list-style-type: none"> 1) Lubricate four universal joints through fittings with GAA. Universal joints are on ends of propeller shafts. See Universal Joint Lubrication Table (Table 12, page 0155 00-27). 2) Clean fittings with cleaning compound (WP 0928 00, Item 19) prior to lubrication. Check/lubricate grease fitting points after washing or fording. 	

**UNIVERSAL JOINT
(4 FITTINGS)**

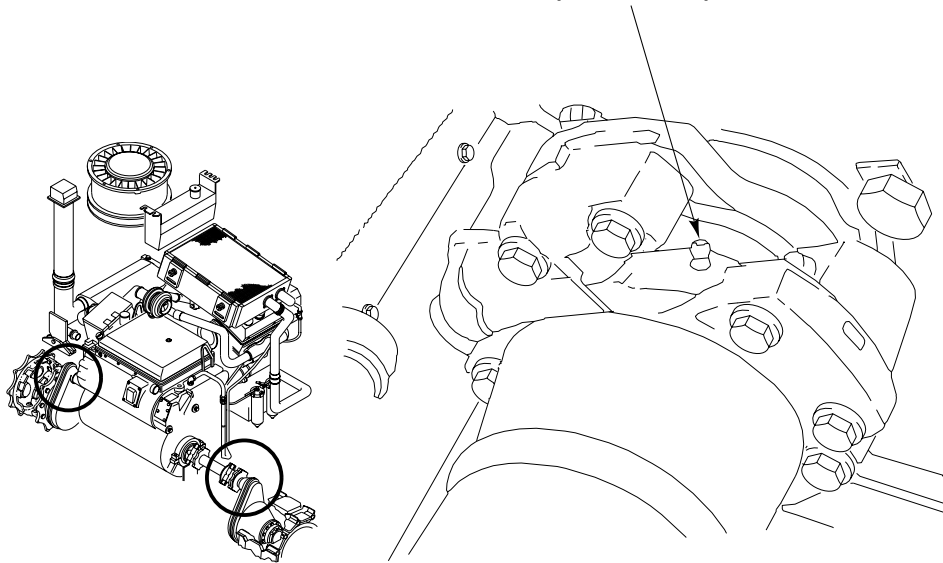

PREVENTIVE MAINTENANCE CHECKS AND SERVICES (PMCS), INCLUDING LUBRICATION INSTRUCTIONS — Continued

0155 00

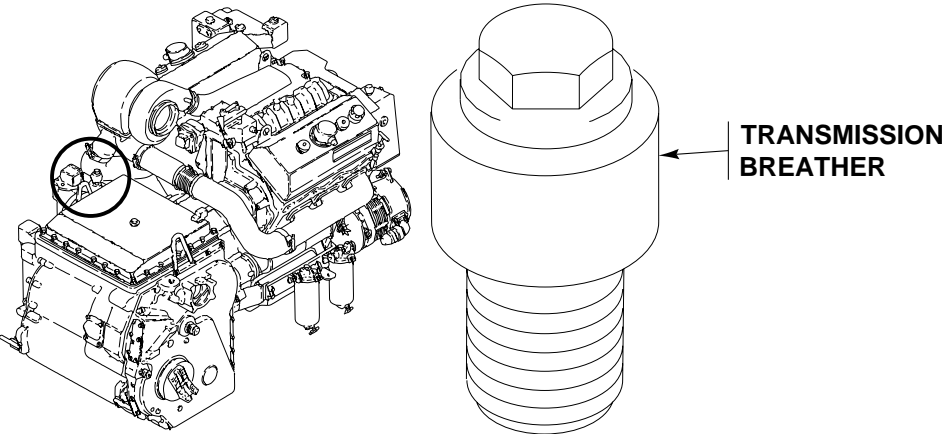
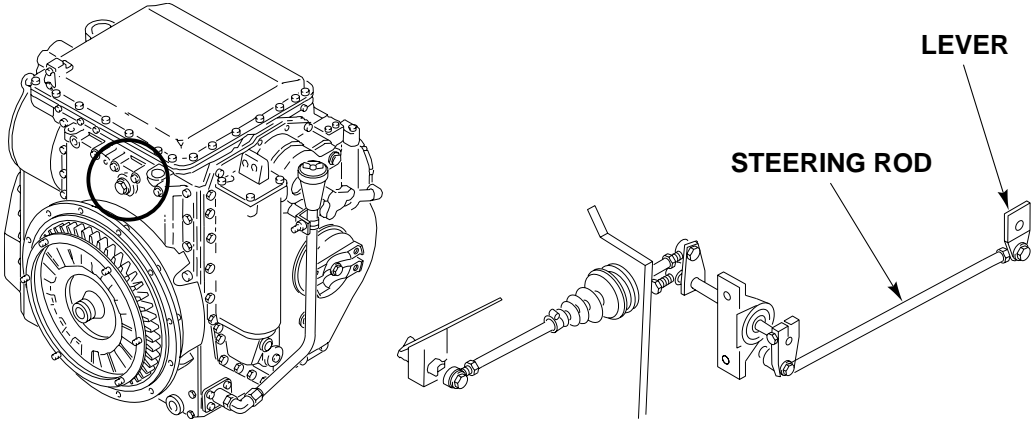
ITEM NO.	INTERVAL	MAN-HOUR	ITEM TO BE CHECKED OR SERVICED	CREWMEMBER PROCEDURE	EQUIPMENT NOT READY/ AVAILABLE IF:
51	Semi-Annual		Transmission Breather	<p>a. Remove transmission breather and check for cracks, dents or stripped threads. Replace damaged breather.</p> <p>b. Clean transmission breather with cleaning compound (WP 0928 00, Item 19). Dry breather and install on transmission.</p>	
					
52	Semi-Annual		Transmission Rod and Connecting link	<p>a. Check steering rod and connecting link at lever on top of transmission for ease of movement from low to full position. If linkage doesn't move easily, troubleshoot steering system (WP 0071 00).</p>	
					

PREVENTIVE MAINTENANCE CHECKS AND SERVICES (PMCS), INCLUDING LUBRICATION INSTRUCTIONS — Continued

0155 00

ITEM NO.	INTERVAL	MAN-HOUR	ITEM TO BE CHECKED OR SERVICED	<u>CREWMEMBER</u> PROCEDURE	EQUIPMENT NOT READY/ AVAILABLE IF:
53	Semi-Annual		Power Plant Compartments	a. Open power plant front access door (see your -10) and remove hull access cover (WP 0449 00). b. Clean power plant compartment with cleaning compound (WP 0928 00, Item 19). Remove debris and wipe up spilled oil and fuel.	
54	Semi-Annual		Power Plant Components	a. Check power plant components for looseness. Tighten any loose mounting components on the starter, generator, etc.	Any damage that would prevent operation of the vehicle.

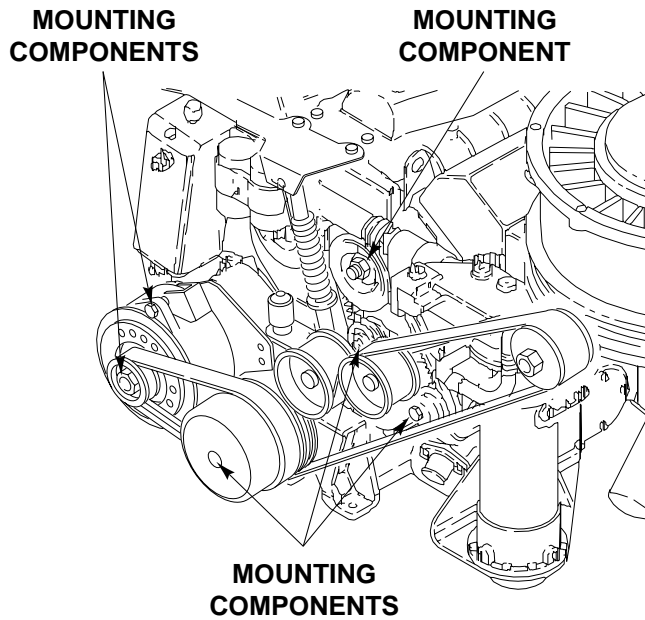

PREVENTIVE MAINTENANCE CHECKS AND SERVICES (PMCS), INCLUDING LUBRICATION INSTRUCTIONS — Continued

0155 00

ITEM NO.	INTERVAL	MAN-HOUR	ITEM TO BE CHECKED OR SERVICED	<u>CREWMEMBER</u> PROCEDURE	EQUIPMENT NOT READY/ AVAILABLE IF:
55	Semi-Annual		Power Plant Mount	a. Tighten loose mount screws (on forward engine mount) to 100-120 lb-ft (136–163 N·m) torque. Use torque wrench (WP 0926 00, Item 85) and socket set (WP 0926 00, Item 71).	Any cracked or broken nuts.

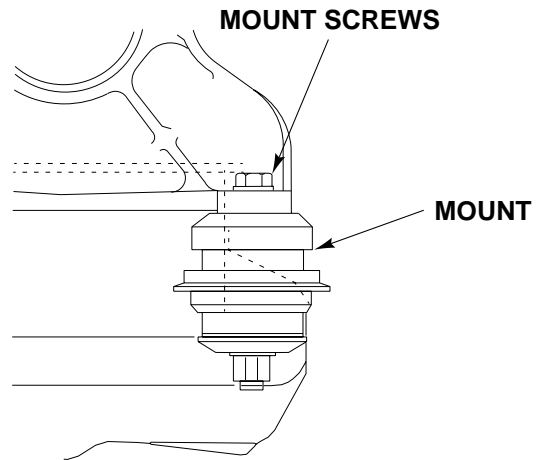
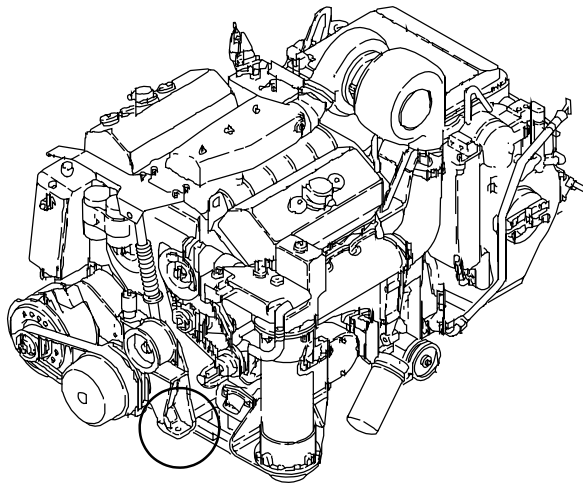

PREVENTIVE MAINTENANCE CHECKS AND SERVICES (PMCS), INCLUDING LUBRICATION INSTRUCTIONS — Continued

0155 00

ITEM NO.	INTERVAL	MAN-HOUR	ITEM TO BE CHECKED OR SERVICED	<u>CREWMEMBER</u> PROCEDURE	EQUIPMENT NOT READY/ AVAILABLE IF:
56	Semi-Annual		Drive Belts	a. Check fan belts for proper tension. Adjust if needed (WP 0242 00). b. Check generator drive belts for proper tension. Adjust if needed (WP 0252 00). c. Replace any frayed or cracked fan belts (WP 0243 00) and frayed or cracked generator drive belts (WP 0253 00).	Any belt that is missing, broken, frayed more than 2 inches, cracks 1/8 inch in depth or is 50% of belt thickness.

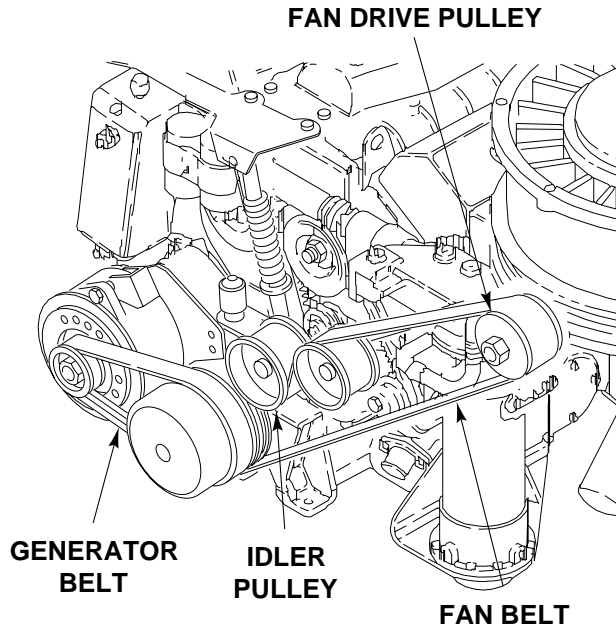

PREVENTIVE MAINTENANCE CHECKS AND SERVICES (PMCS), INCLUDING LUBRICATION INSTRUCTIONS — Continued

0155 00

ITEM NO.	INTERVAL	MAN-HOUR	ITEM TO BE CHECKED OR SERVICED	<u>CREWMEMBER PROCEDURE</u>	EQUIPMENT NOT READY/AVAILABLE IF:
57	Semi-Annual	0.4	Cooling Fan	a. Replace cracked or bent drive pulley (WP 0244 00) and idler pulley (WP 0240 00).	Any cracked, broken, loose or missing hardware.

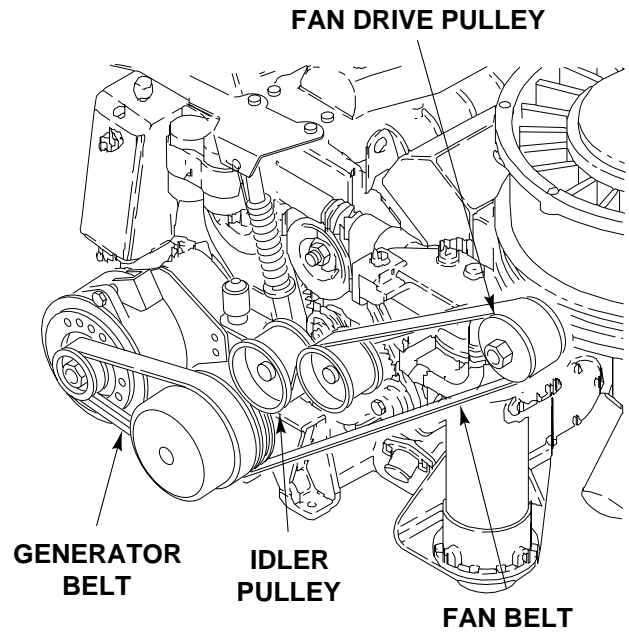

**PREVENTIVE MAINTENANCE CHECKS AND SERVICES (PMCS), INCLUDING
LUBRICATION INSTRUCTIONS — Continued**

0155 00

ITEM NO.	INTERVAL	MAN-HOUR	ITEM TO BE CHECKED OR SERVICED	<u>CREWMEMBER</u> PROCEDURE	EQUIPMENT NOT READY/ AVAILABLE IF:
				<p>b. Every 1500 miles or semi-annually, lubricate pulley support arm with GAA. Use grease gun with flexible adapter on fitting. See Pulley Support Arm Lubrication Table (Table 6, page 0155 00-21).</p>	

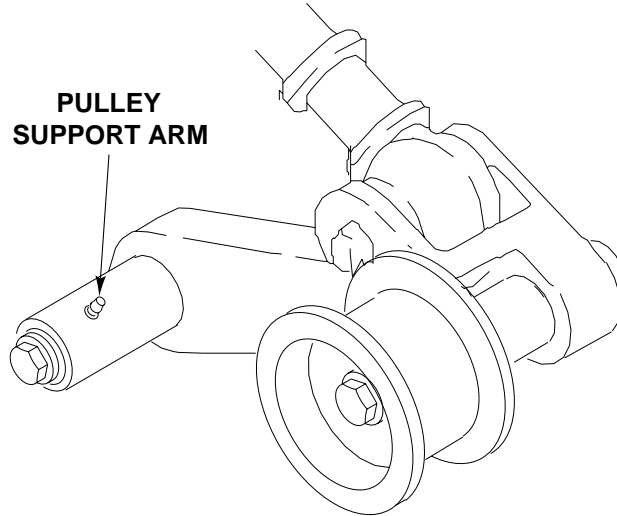
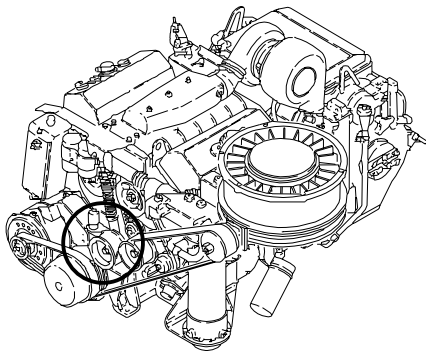

PREVENTIVE MAINTENANCE CHECKS AND SERVICES (PMCS), INCLUDING LUBRICATION INSTRUCTIONS — Continued

0155 00

ITEM NO.	INTERVAL	MAN-HOUR	ITEM TO BE CHECKED OR SERVICED	CREWMEMBER PROCEDURE	EQUIPMENT NOT READY/ AVAILABLE IF:
58	Semi-Annual		Cooling System: Hoses, Coolant, Pump, and Drive Belt	<ul style="list-style-type: none"> a. Replace cracked or broken hoses (WP 0233 00). b. Tighten loose clamps. Replace leaking coolant pump (WP 0241 00). c. Check engine coolant pump belt tension. Adjust, if necessary (WP 0239 00). d. Replace cracked or frayed engine water pump belts (WP 0240 00). 	Any missing, cracked, broken hardware or Class III leaks. Drive belt frays more than 2 inches, cracks 1/8 inch in depth or 50% of the belt thickness.

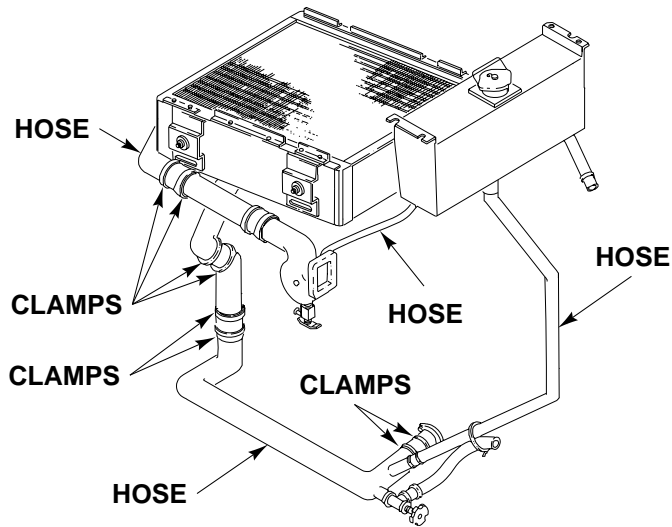

PREVENTIVE MAINTENANCE CHECKS AND SERVICES (PMCS), INCLUDING LUBRICATION INSTRUCTIONS — Continued

0155 00

ITEM NO.	INTERVAL	MAN-HOUR	ITEM TO BE CHECKED OR SERVICED	CREWMEMBER PROCEDURE	EQUIPMENT NOT READY/AVAILABLE IF:
59	Semi-Annual		Radiator	a. Clean radiator (WP 0228 00). b. Replace leaking radiator (WP 0229 00).	Any Class II leak.
60	Semi-Annual	0.4	Fan Gearbox	a. Check fan gearbox oil level. Add OE/HDO or OEA, as needed, to bring oil level to center of sight glass.	No oil in sight glass. Any Class II leak or greater oil leak.

**PREVENTIVE MAINTENANCE CHECKS AND SERVICES (PMCS), INCLUDING
LUBRICATION INSTRUCTIONS — Continued**

0155 00

ITEM NO.	INTERVAL	MAN-HOUR	ITEM TO BE CHECKED OR SERVICED	<u>CREWMEMBER</u> PROCEDURE	EQUIPMENT NOT READY/ AVAILABLE IF:
				<p style="text-align: center;">NOTE</p> <p>Drain oil only when hot after operation.</p> <p>b. Drain gearbox every 150 hours/1500 miles or semiannually.</p> <ol style="list-style-type: none"> 1) Place a suitable container under fan gearbox drain. 2) Remove screw and washer from gearbox housing and drain oil into container (WP 0248 00). Discard packing. 3) Inspect screw, washer and oil for metallic particles and foreign matter. If metal chips are found, notify your supervisor. 4) Lubricate new performed packing with OE/HDO prior to installing. 5) Install screw and washer in gearbox housing (WP 0248 00). Tighten screw. Do NOT over tighten. 6) Fill gearbox with enough OE/HDO oil to bring the level to center of sight glass. See Fan Gearbox Lubrication Table (Table 5, page 0155 00-20). 	

**PREVENTIVE MAINTENANCE CHECKS AND SERVICES (PMCS), INCLUDING
LUBRICATION INSTRUCTIONS — Continued**

0155 00

ITEM NO.	INTERVAL	MAN-HOUR	ITEM TO BE CHECKED OR SERVICED	<u>CREWMEMBER</u> PROCEDURE	EQUIPMENT NOT READY/ AVAILABLE IF:
61	Semi-Annual		Operate Air Box Heater Air Pump	<p style="text-align: center;">NOTE</p> <p>The purpose of the item is to exercise the vanes in the air box heater air pump.</p> <p>a. Disconnect lead from fuel shutoff solenoid (WP 0205 00).</p> <p>b. To prevent engine from starting, pull fuel cutoff out (see your -10).</p> <p style="text-align: center;">CAUTION</p> <p>Air pump can be damaged if switch is held too long. Do not exceed a total of 20 seconds of operation.</p> <p>c. Have helper crank engine and run air pump at the same time intermittently for a total of 20 seconds. Listen for air pump operation (see your -10).</p> <p>d. Connect lead to fuel shutoff solenoid.</p> <p>e. Lubricate air motor with OE/HDO every 150 hours/1500 miles, semiannually or as required.</p>	

PREVENTIVE MAINTENANCE CHECKS AND SERVICES (PMCS), INCLUDING LUBRICATION INSTRUCTIONS — Continued

0155 00

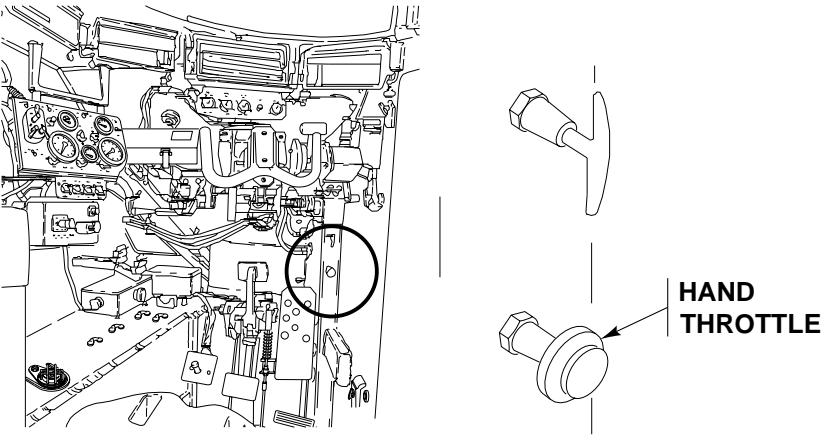
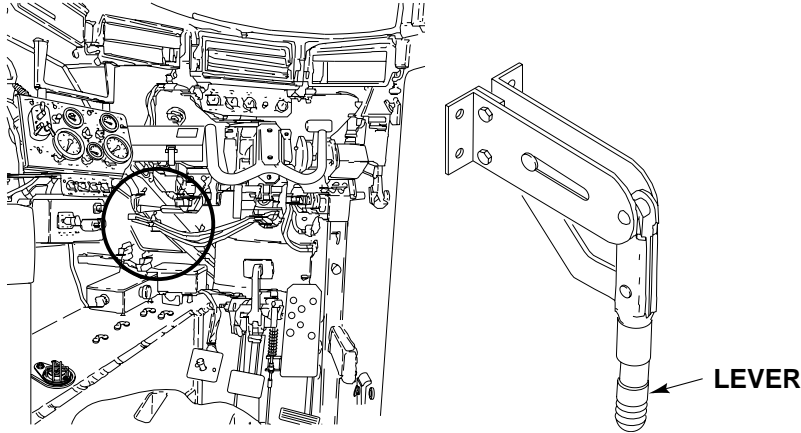
ITEM NO.	INTERVAL	MAN-HOUR	ITEM TO BE CHECKED OR SERVICED	CREWMEMBER PROCEDURE	EQUIPMENT NOT READY/AVAILABLE IF:
62	Semi-Annual		Throttle Controls and Transmission	a. Check hand throttle for ease of movement from low to full position. If throttle doesn't move easily, adjust (WP 0213 00, WP 0214 00, WP 0219 00).	Any binding, broken, cracked, missing or loose hardware.
 <p>The diagram shows a top-down view of the engine compartment with a circle highlighting the throttle linkage area. To the right, a detailed view of the hand throttle assembly is shown, consisting of a T-shaped handle and a cylindrical base. An arrow points to the base with the label 'HAND THROTTLE'.</p>					
63	Semi-Annual		Parking Brake Linkage	a. Check parking brake linkage for proper adjustment. If lever doesn't move easily, adjust parking brake (WP 0408 00).	
 <p>The diagram shows a top-down view of the engine compartment with a circle highlighting the parking brake linkage area. To the right, a detailed view of the parking brake lever is shown, which is a long metal arm with a threaded end. An arrow points to the threaded end with the label 'LEVER'.</p>					

**PREVENTIVE MAINTENANCE CHECKS AND SERVICES (PMCS), INCLUDING
LUBRICATION INSTRUCTIONS — Continued**

0155 00

ITEM NO.	INTERVAL	MAN-HOUR	ITEM TO BE CHECKED OR SERVICED	<u>CREWMEMBER</u> PROCEDURE	EQUIPMENT NOT READY/ AVAILABLE IF:
64	Semi-Annual	0.3	Service Brake Linkage	a. Check service brake pedal and linkage for proper adjustment (WP 0407 00).	

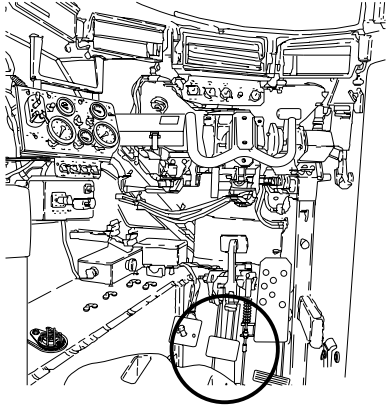
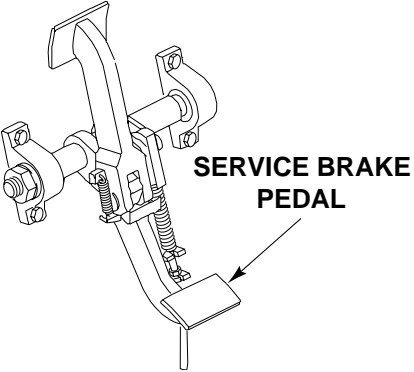



PREVENTIVE MAINTENANCE CHECKS AND SERVICES (PMCS), INCLUDING LUBRICATION INSTRUCTIONS — Continued

0155 00

ITEM NO.	INTERVAL	MAN-HOUR	ITEM TO BE CHECKED OR SERVICED	CREWMEMBER PROCEDURE	EQUIPMENT NOT READY/ AVAILABLE IF:
				<p style="text-align: center;">NOTE</p> <p>When grease fittings will not accept GAA, notify your supervisor.</p> <p>b. Lubricate foot brake cross-shaft bearings.</p> <ol style="list-style-type: none"> 1) Every 1500 miles or semi-annually, lubricate foot brake cross-shaft bearings with GAA through fitting. 2) Clean fittings with cleaning compound (WP 0928 00, Item 19) prior to lubrication. 3) Check/lubricate grease fitting points after washing or fording. See Foot Brake Cross-Shaft Lubrication Table (Table 8, page 0155 00-23). 	

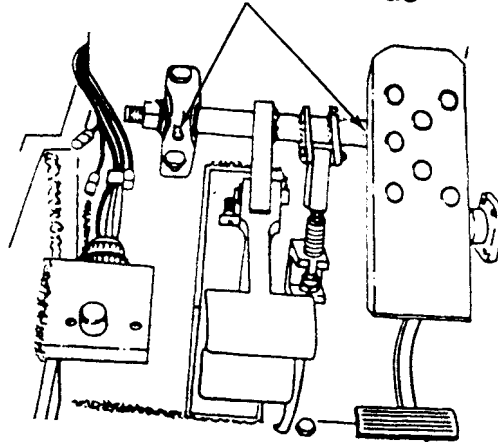
FOOT BRAKE CROSS-SHAFT BEARINGS



**PREVENTIVE MAINTENANCE CHECKS AND SERVICES (PMCS), INCLUDING
LUBRICATION INSTRUCTIONS — Continued**

0155 00

ITEM NO.	INTERVAL	MAN-HOUR	ITEM TO BE CHECKED OR SERVICED	<u>CREWMEMBER</u> PROCEDURE	EQUIPMENT NOT READY/ AVAILABLE IF:
65	Semi-Annual		Fuel System	<p style="text-align: center;">WARNING</p>  <p>Fuel can catch fire and burn you. Do not smoke. Disconnect battery ground cables before you work on fuel systems. Wipe up spilled fuel.</p> <ul style="list-style-type: none"> a. Check fuel tanks for leaks. Repair or replace fuel tanks that leak (WP 0179 00 or WP 0180 00). b. Replace fuel hoses and tubes that are cracked, crimped or worn (WP 0192 00, WP 0193 00, WP 0194 00). c. Replace cracked or stripped fittings (WP 0192 00, WP 0195 00). 	Any fuel leaks or cracked, broken, stripped or crimped hardware.

PREVENTIVE MAINTENANCE CHECKS AND SERVICES (PMCS), INCLUDING LUBRICATION INSTRUCTIONS — Continued

0155 00

ITEM NO.	INTERVAL	MAN-HOUR	ITEM TO BE CHECKED OR SERVICED	CREWMEMBER PROCEDURE	EQUIPMENT NOT READY/AVAILABLE IF:
66	Semi-Annual		Fuel Cutoff	<p>a. Operate fuel cutoff to check for binding. If binding occurs, adjust (WP 0220 00).</p> <p>b. Operate accelerator to check for binding linkage. If binding occurs, adjust (WP 0214 00).</p> <p>c. Move transmission range controller through all gears to check for binding. If binding occurs, adjust (WP 0386 00, WP 0387 00).</p>	Any binding, broken, cracked, missing or loose hardware.

RANGE CONTROLLER

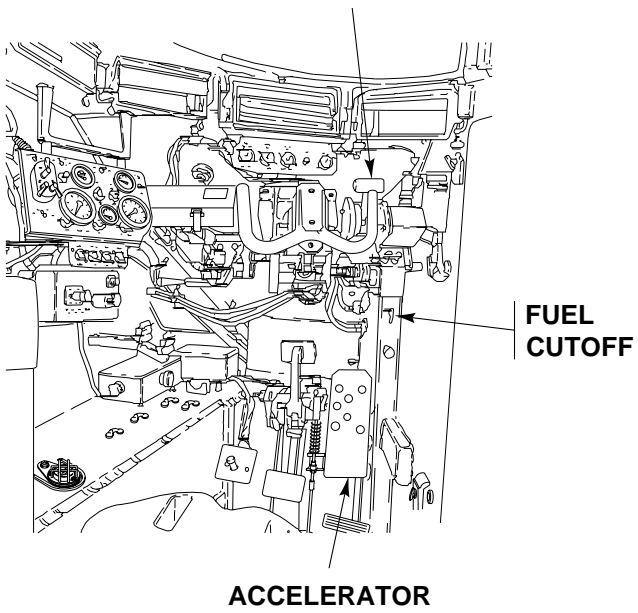

FUEL CUTOFF

ACCELERATOR

PREVENTIVE MAINTENANCE CHECKS AND SERVICES (PMCS), INCLUDING LUBRICATION INSTRUCTIONS — Continued

0155 00

ITEM NO.	INTERVAL	MAN-HOUR	ITEM TO BE CHECKED OR SERVICED	CREWMEMBER PROCEDURE	EQUIPMENT NOT READY/AVAILABLE IF:
67	Semi-Annual	0.3	Fuel Filters	<p style="text-align: center;">WARNING</p>  <p>Fuel can catch fire and burn you. Do not smoke. Disconnect battery ground cables before you work on fuel system. Wipe up spilled fuel.</p> <p style="text-align: center;">NOTE</p> <p>Large amounts of sediment or debris may indicate contamination of fuel tanks.</p> <p>a. Every 150 hours/1500 miles or semi-annually, inspect primary and secondary filter shells. Replace primary and secondary fuel filter elements (WP 0202 00). See Fuel Filter Lubrication Table (Table 2, page 0155 00-17).</p> <p>b. If engine will not start or hesitates, check for trapped air and drain fuel filter.</p>	Any fuel leaks.

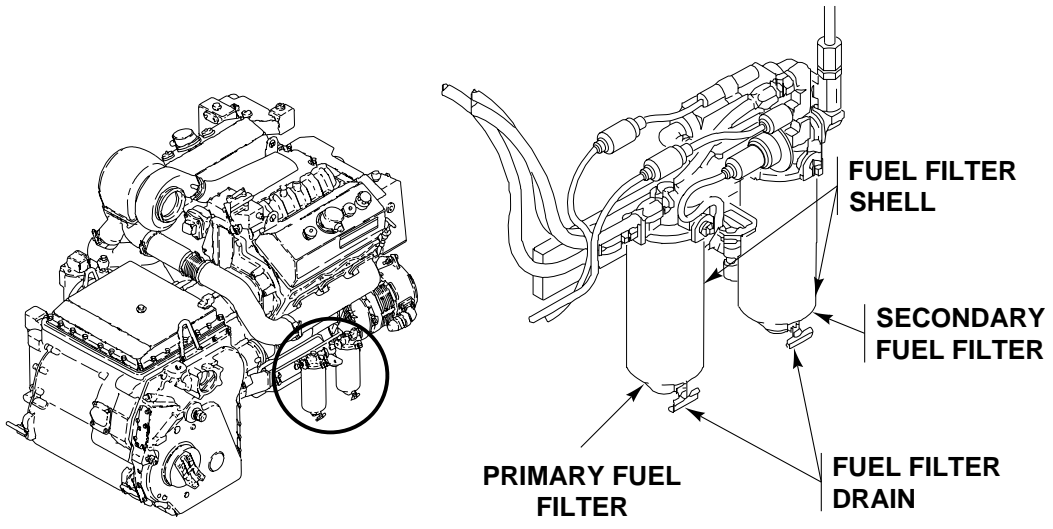

**PREVENTIVE MAINTENANCE CHECKS AND SERVICES (PMCS), INCLUDING
LUBRICATION INSTRUCTIONS — Continued**

0155 00

ITEM NO.	INTERVAL	MAN-HOUR	ITEM TO BE CHECKED OR SERVICED	<u>CREWMEMBER</u> PROCEDURE	EQUIPMENT NOT READY/ AVAILABLE IF:
				<ol style="list-style-type: none"> 1) Remove driver's power plant access panel (see your -10). 2) Place suitable container under primary fuel filter. Open drain cock and drain water and sediment from primary fuel filter. When clean fuel starts to drain out, close drain cock. 3) Repeat Step 67b2 for secondary fuel filter. 4) Check for fuel leaks at primary and secondary fuel filters while engine is running. If leak is found, remove and install primary and secondary fuel filter elements and check for proper fit and seal (WP 0202 00). 	

PREVENTIVE MAINTENANCE CHECKS AND SERVICES (PMCS), INCLUDING LUBRICATION INSTRUCTIONS — Continued

0155 00

ITEM NO.	INTERVAL	MAN-HOUR	ITEM TO BE CHECKED OR SERVICED	<u>CREWMEMBER</u> PROCEDURE	EQUIPMENT NOT READY/ AVAILABLE IF:
68	Semi-Annual	1.0	Hydraulic System	<p style="text-align: center;">WARNING</p>  <p>Hydraulic fluid is poison and can be absorbed through your skin. Wash off hydraulic fluid that contacts your skin. Fire resistant hydraulic (FRH) fluid may contain Tricresyl Phosphate which, if taken internally, can produce paralysis. Hydraulic fluid may be absorbed through the skin. Wear long sleeves, gloves, goggles, and face shield. If FRH gets in eyes, wash them immediately and get medical aid immediately. If FRH gets on skin, thoroughly wash with soap and water. Wash hands thoroughly prior to eating or smoking.</p> <p>a. Tighten or replace cracked or leaking fittings on hydraulic reservoir or pump (WP 0655 00, WP 0671 00, or WP 0672 00).</p> <p>b. Replace leaky pump (WP 0655 00).</p> <p>c. Tighten tubes or hoses or leak (WP 0668 00).</p>	Any hydraulic leaks, fluid not visible on sight gauge, cracked, broken, crimped, missing, or loose hardware.

PREVENTIVE MAINTENANCE CHECKS AND SERVICES (PMCS), INCLUDING LUBRICATION INSTRUCTIONS — Continued

0155 00

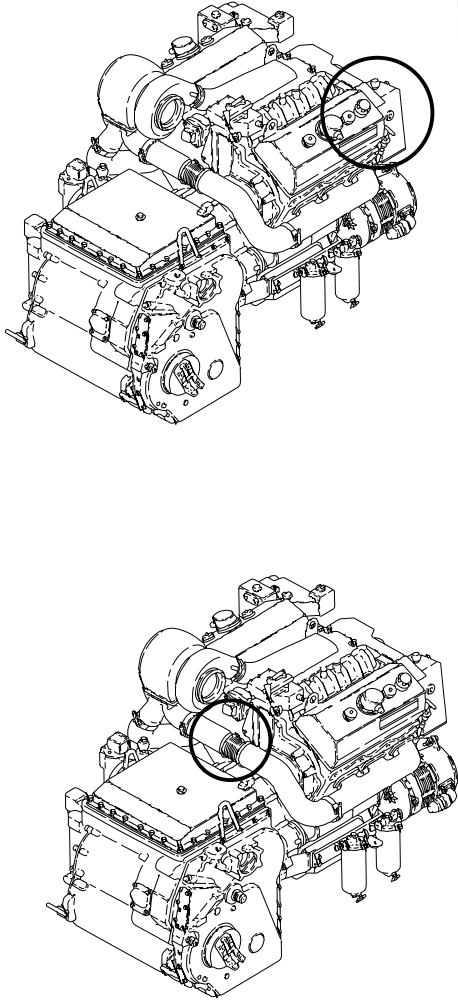
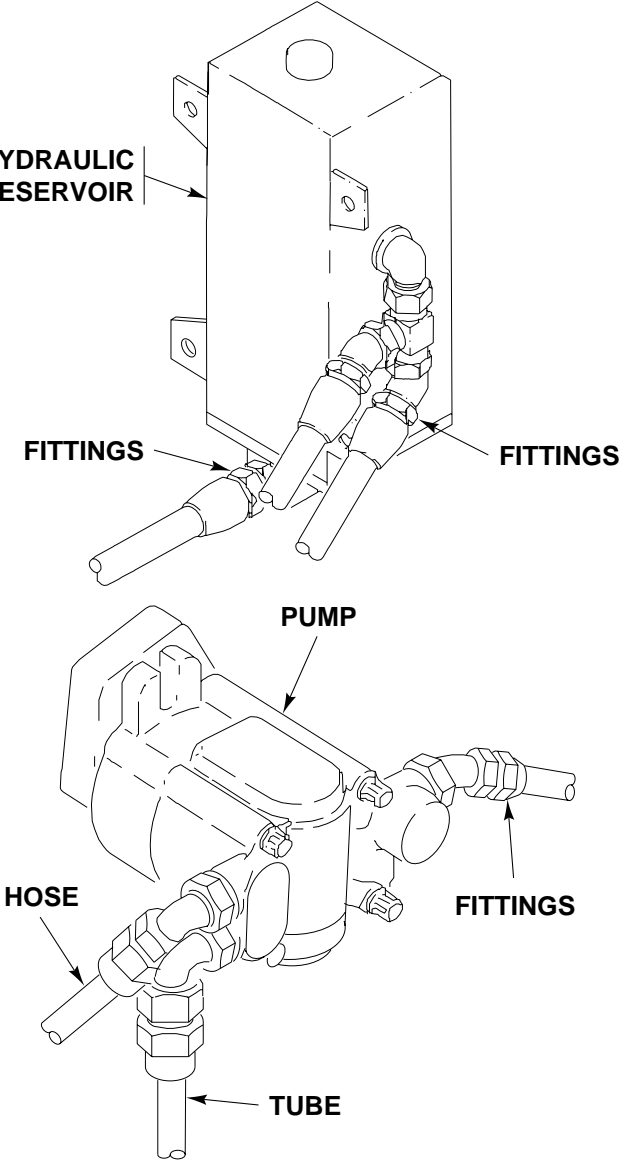
ITEM NO.	INTERVAL	MAN-HOUR	ITEM TO BE CHECKED OR SERVICED	CREWMEMBER PROCEDURE	EQUIPMENT NOT READY/AVAILABLE IF:
					

**PREVENTIVE MAINTENANCE CHECKS AND SERVICES (PMCS), INCLUDING
LUBRICATION INSTRUCTIONS — Continued**

0155 00

ITEM NO.	INTERVAL	MAN-HOUR	ITEM TO BE CHECKED OR SERVICED	CREWMEMBER PROCEDURE	EQUIPMENT NOT READY/ AVAILABLE IF:
				<p style="text-align: center;">WARNING</p>  <p>Lowering ramp could injure personnel. Make sure no one is in ramp zone before you lower the ramp. Unlocked ramp can fall open suddenly. Personnel can be killed or injured. Ramp system and hull can get damaged if ramp unlocks when carrier is in operation. Do not operate carrier if locks do not secure ramp properly. Keep away from ramps that have come open during carrier operation.</p> <p>d. Tighten or replace cracked or leaky fitting on ramp cylinder and ramp control.</p> <p>e. Replace leaky ramp cylinder (WP 0656 00).</p> <p>f. Replace tubes or hoses that are cracked, crimped, or worn (WP 0660 00) or (WP 0668 00).</p> <p>g. Drain hydraulic system tank and service strainer every 1500 miles, semi-annually or when hydraulic fluid is changed to FRH.</p> <ol style="list-style-type: none"> 1) Lower ramp (see your -10). 2) Place a suitable container under drain elbow on bottom of tank. 3) Remove drain cap and preformed packing from drain elbow. Discard packing. 4) Service hydraulic system tank breather (WP 0670 00) and strainer (WP 0669 00). 5) Install drain cap with new preformed packing on drain elbow. 6) Remove fill plug and preformed packing from top of tank. 	<p>Pumps fail to operate or raise ramp.</p>

PREVENTIVE MAINTENANCE CHECKS AND SERVICES (PMCS), INCLUDING LUBRICATION INSTRUCTIONS — Continued

0155 00

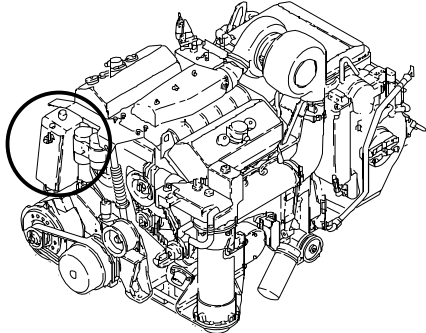
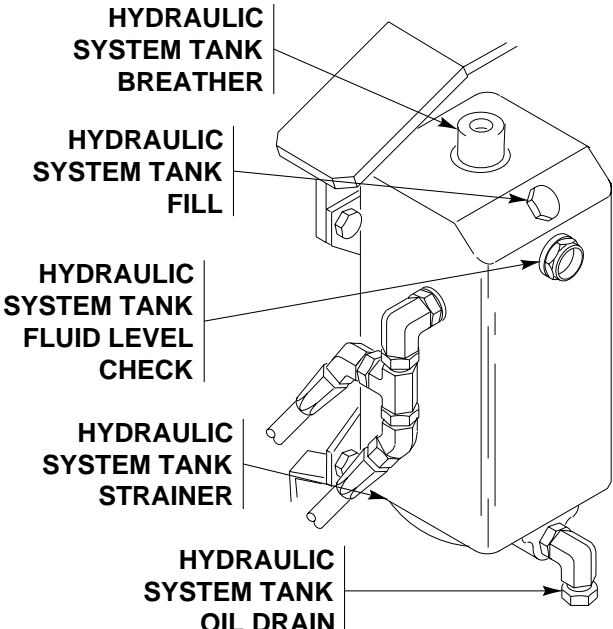
ITEM NO.	INTERVAL	MAN-HOUR	ITEM TO BE CHECKED OR SERVICED	CREWMEMBER PROCEDURE	EQUIPMENT NOT READY/ AVAILABLE IF:
				<p>7) Fill hydraulic tank with FRH to bring level halfway in sight glass. Hydraulic tank takes approximately 3 1/2 quarts. See Hydraulic System Lubrication Table (Table 7, page 0155 00-22).</p> <p>8) Install fill plug with new preformed packing in top of tank.</p> <p>h. When changing from OHA to FRH hydraulic fluid, flush tank as follows.</p> <ol style="list-style-type: none"> 1) Drain and fill tank. See Step 68g. 2) Raise and lower ramp several times (see your -10). 3) Drain and fill tank again. See Step 68g.  <ol style="list-style-type: none"> 4) Test hydraulic ramp system. i. Tighten tubes and hoses that leak. j. Replace tubes or hoses that are cracked, crimped or worn (WP 0660 00, WP 0668 00). k. Replace ramp cylinder that leaks (WP 0656 00). 	

**PREVENTIVE MAINTENANCE CHECKS AND SERVICES (PMCS), INCLUDING
LUBRICATION INSTRUCTIONS — Continued**

0155 00

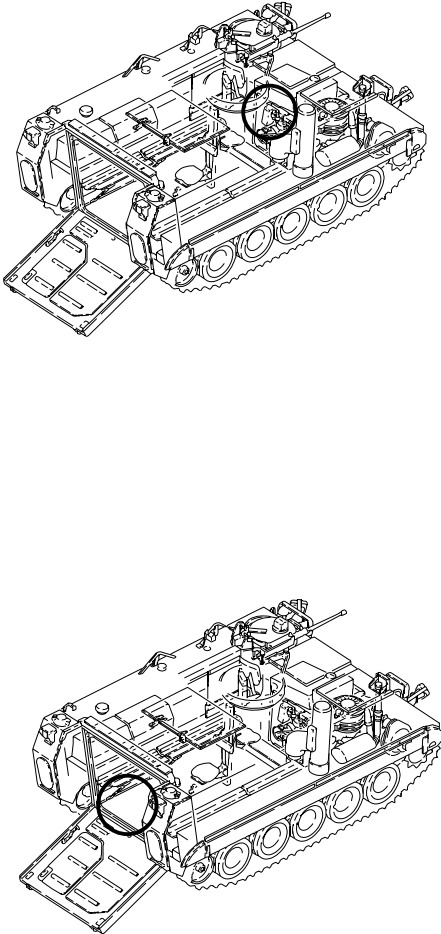
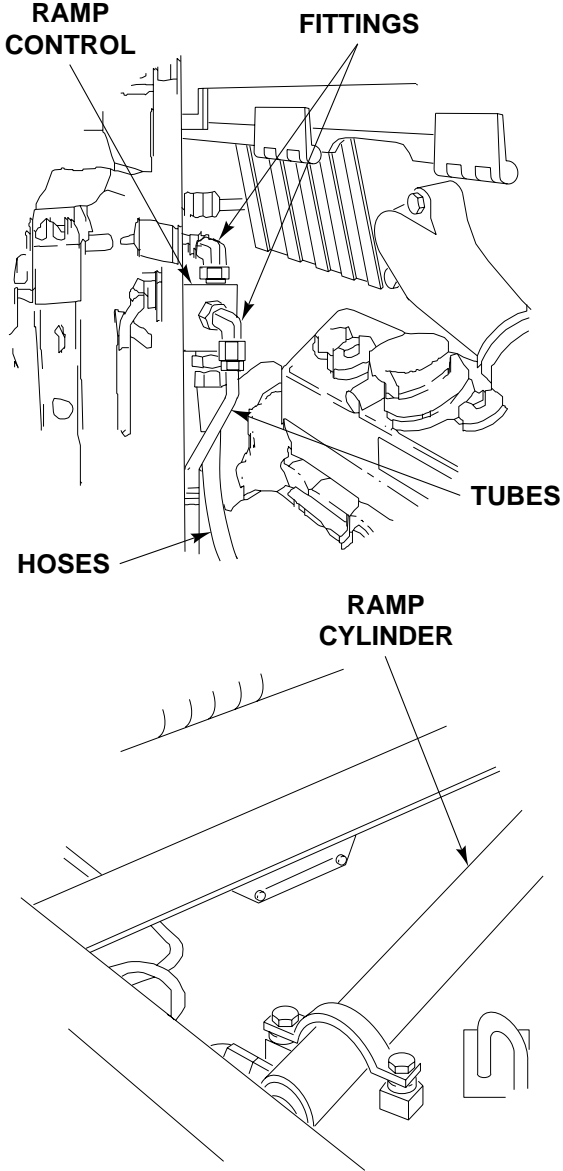
ITEM NO.	INTERVAL	MAN-HOUR	ITEM TO BE CHECKED OR SERVICED	CREWMEMBER PROCEDURE	EQUIPMENT NOT READY/AVAILABLE IF:
					

PREVENTIVE MAINTENANCE CHECKS AND SERVICES (PMCS), INCLUDING LUBRICATION INSTRUCTIONS — Continued

0155 00

ITEM NO.	INTERVAL	MAN-HOUR	ITEM TO BE CHECKED OR SERVICED	CREWMEMBER PROCEDURE	EQUIPMENT NOT READY/ AVAILABLE IF:
69	Semi-Annual		Portable and Fixed Fire Extinguisher	<p style="text-align: center;">WARNING</p>  <p>You could be injured if cylinder discharges when it is out of its mounting brackets or is dropped. Handle with great care.</p> <ol style="list-style-type: none"> a. Weigh portable fire extinguishers. Recharge or exchange fire extinguisher if weight loss is more than 10 percent of charged weight stamped on bottle. Fill out DA form 2402 to exchange cylinders. b. Check wire seal. Replace broken or damaged seal. 	Extinguisher is missing or seal/hardware is missing or broken.

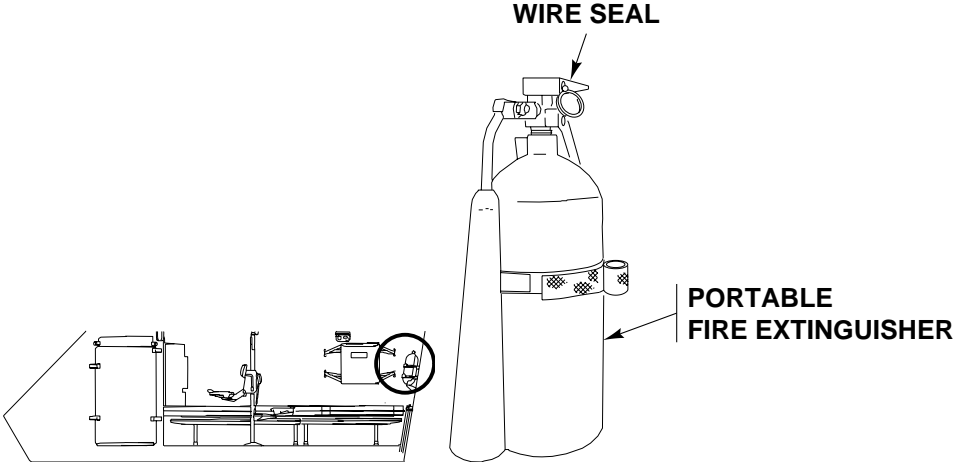

**PREVENTIVE MAINTENANCE CHECKS AND SERVICES (PMCS), INCLUDING
LUBRICATION INSTRUCTIONS — Continued**

0155 00

ITEM NO.	INTERVAL	MAN-HOUR	ITEM TO BE CHECKED OR SERVICED	<u>CREWMEMBER</u> PROCEDURE	EQUIPMENT NOT READY/ AVAILABLE IF:
70	Semi-Annual		Fixed Fire Extinguisher	<p style="text-align: center;"><u>CAUTION</u></p> <p>Fire extinguisher control valve sealed with steel wire will not work. Make sure seal wire is made out of .020 light copper.</p> <p>a. Remove and weigh fixed fire extinguisher cylinder (WP 0898 00).</p> <p>b. Recharge or exchange fire extinguisher if weight loss is more than 10 percent of charged weight stamped on bottle.</p> <p>c. Inspect fire extinguisher cylinder data plate to ensure that a hydrostatic test has been performed within the past 5 years. Faulty extinguishers, or those beyond the test time limit (5 years), shall be declared unserviceable and replaced.</p> <p style="text-align: center;"><u>CAUTION</u></p> <p>Fire extinguisher control valve sealed with steel wire WILL NOT work. Use .020 thin copper wire.</p> <p>d. Before reconnecting cylinder, operate discharge handles to be sure cables and controls work properly.</p> <p>e. Install cylinder and replace copper seal wires (WP 0898 00).</p> <p>f. Replace discharge tubes that are crimped, plugged, or cracked (WP 0899 00).</p>	Extinguisher is missing or seal/lockwire missing or broken, bottles are overdue for hydrostatic test. Lock wire is not .020 light copper.

**PREVENTIVE MAINTENANCE CHECKS AND SERVICES (PMCS), INCLUDING
LUBRICATION INSTRUCTIONS — Continued**

0155 00

ITEM NO.	INTERVAL	MAN-HOUR	ITEM TO BE CHECKED OR SERVICED	CREWMEMBER PROCEDURE	EQUIPMENT NOT READY/AVAILABLE IF:		

**PREVENTIVE MAINTENANCE CHECKS AND SERVICES (PMCS), INCLUDING
LUBRICATION INSTRUCTIONS — Continued**

0155 00

ITEM NO.	INTERVAL	MAN-HOUR	ITEM TO BE CHECKED OR SERVICED	<u>CREWMEMBER</u> PROCEDURE	EQUIPMENT NOT READY/ AVAILABLE IF:
71	Semi-Annual		Batteries	<p style="text-align: center;">WARNING</p> <div style="text-align: center;">  </div> <p>Battery posts and cables touched by metal objects can short circuit and burn you or injure you. Use caution when you work with tools or other metal objects. Do not wear jewelry when you work on electrical system. Electrical current can burn you.</p> <p style="text-align: center;">NOTE</p> <p>Location of batteries and connection of battery leads varies by model. Model M1064A3 has two ground (negative) leads that need to be disconnected when performing any maintenance. All other models have one ground (negative) lead to be disconnected.</p> <ol style="list-style-type: none"> a. Remove battery ground lead before you start task (WP 0338 00), (WP 0340 00), (WP 0345 00). b. Check battery posts and cables (WP 0095 00). c. Check specific gravity of batteries (TM 9-6100-200-14). 	<p>Any leaks, loose, damaged, cracked, broken, or missing battery or hardware.</p> <p>Specific gravity is not within set standards.</p>

PREVENTIVE MAINTENANCE CHECKS AND SERVICES (PMCS), INCLUDING LUBRICATION INSTRUCTIONS — Continued

0155 00

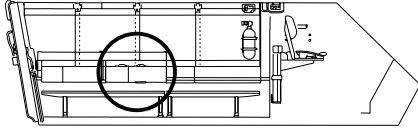
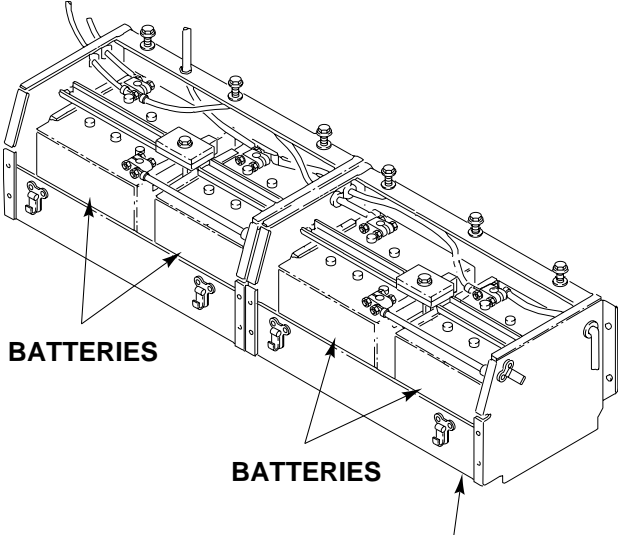
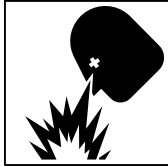
ITEM NO.	INTERVAL	MAN-HOUR	ITEM TO BE CHECKED OR SERVICED	CREWMEMBER PROCEDURE	EQUIPMENT NOT READY/ AVAILABLE IF:
			  <p>BATTERIES</p> <p>BATTERIES</p> <p>BATTERY BOX</p>	<p>WARNING</p>  <p>Gas from batteries can explode and injure you. Do not allow sparks near batteries. Battery acid can blind or burn you. Do not get acid on your skin or eyes.</p>	
				<p>d. Check electrolyte level in all cell batteries. Add distilled water as needed. See TM 9-6100-200-14.</p>	<p>One or more batteries unserviceable, missing, cables frayed, or broken.</p>

PREVENTIVE MAINTENANCE CHECKS AND SERVICES (PMCS), INCLUDING LUBRICATION INSTRUCTIONS — Continued

0155 00

ITEM NO.	INTERVAL	MAN-HOUR	ITEM TO BE CHECKED OR SERVICED	<u>CREWMEMBER</u> PROCEDURE	EQUIPMENT NOT READY/ AVAILABLE IF:
				<p>e. Test specific gravity of batteries. See TM 9-6100-200-14.</p> <p>f. Clean vent holes in cell caps. Replace missing or damaged caps.</p> <p>g. Clean terminals, posts, and bolts (WP 0340 00).</p> <p>h. Tighten terminals and bolts with care to avoid damage to batteries. Apply light coat of grease (WP 0928 00, Item 12) to terminals.</p>	

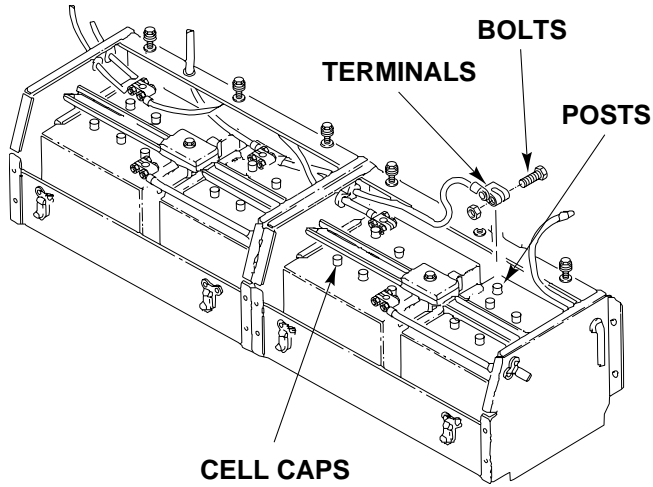

PREVENTIVE MAINTENANCE CHECKS AND SERVICES (PMCS), INCLUDING LUBRICATION INSTRUCTIONS — Continued

0155 00

ITEM NO.	INTERVAL	MAN-HOUR	ITEM TO BE CHECKED OR SERVICED	CREWMEMBER PROCEDURE	EQUIPMENT NOT READY/AVAILABLE IF:
72	Semi-Annual		Driver's Hatch	<p>a. Replace hard, cracked, or cut cushioning pad (WP 0530 00).</p> <p>b. Check driver's night vision quick release for smooth operation.</p> <p>c. Check vision blocks for cracks and chips.</p> <p>d. Replace vision blocks that have more than 50 percent impairment.</p> <p>e. Push driver's release handle up and measure between hatch release handle and washer. Make sure gap is 0.06 to 0.09 inch (1.5 to 2.3 mm). If clearance is not within limits, loosen or tighten nut on cable end, as required.</p>	Any missing lock pins or latches that fail to secure hatch in any position.

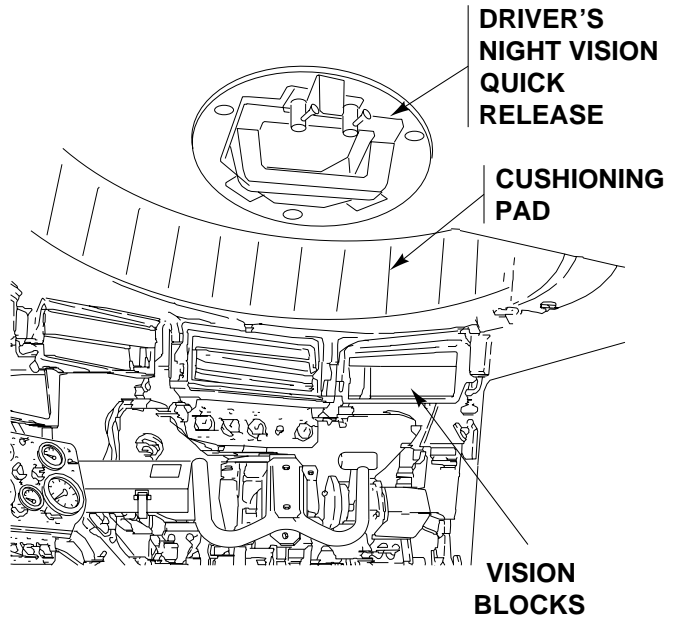
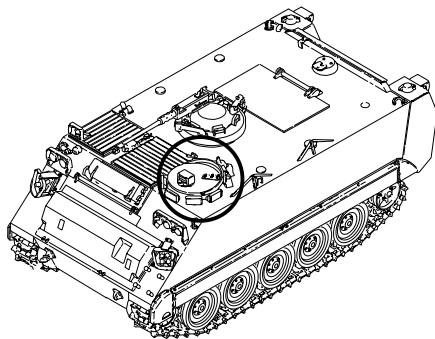

PREVENTIVE MAINTENANCE CHECKS AND SERVICES (PMCS), INCLUDING LUBRICATION INSTRUCTIONS — Continued

0155 00

ITEM NO.	INTERVAL	MAN-HOUR	ITEM TO BE CHECKED OR SERVICED	CREWMEMBER PROCEDURE	EQUIPMENT NOT READY/AVAILABLE IF:
73	Semi-Annual		Dome Lights	<p>a. Check that all dome lights work correctly. Troubleshoot faulty lights (WP 0039 00).</p> <p>b. Tape frayed electrical leads and replace damaged connectors (WP 0382 00).</p>	

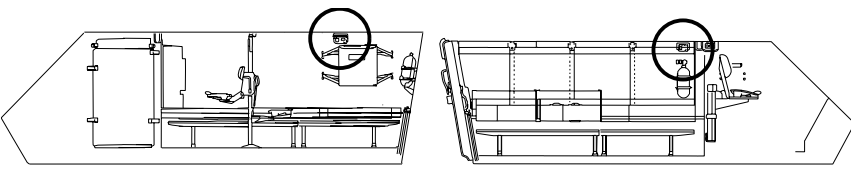

DOME LIGHT

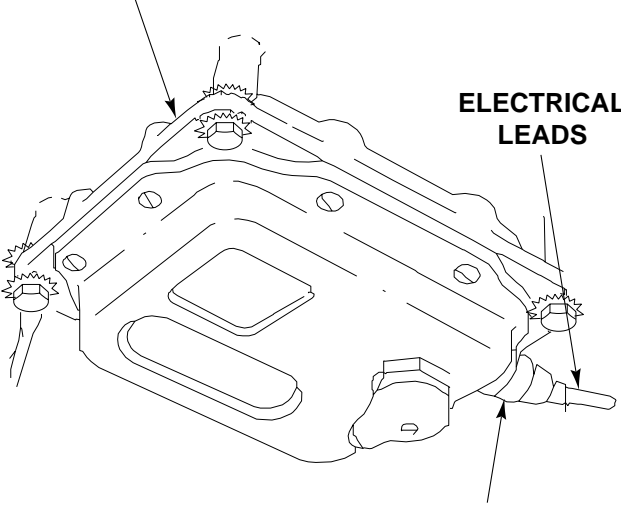

PREVENTIVE MAINTENANCE CHECKS AND SERVICES (PMCS), INCLUDING LUBRICATION INSTRUCTIONS — Continued

0155 00

ITEM NO.	INTERVAL	MAN-HOUR	ITEM TO BE CHECKED OR SERVICED	CREWMEMBER PROCEDURE	EQUIPMENT NOT READY/AVAILABLE IF:
74	Semi-Annual		Dome Lights, Fluorescent Light, and Switches (M577A3 and M1068A3 Only)	<ul style="list-style-type: none"> a. Check that dome lights, blackout lights and fluorescent light work right (see your -10). Troubleshoot faulty lights (WP 0039 00), (WP 0040 00), (WP 0041 00), (WP 0102 00). b. Check dome light switches, blackout bypass switch, and fluorescent light switch for proper operation (see your -10). Troubleshoot faulty switches (WP 0048 00). c. Check that ramp door switch operates properly (see your -10). Troubleshoot faulty switch (WP 0040 00). d. Check that admittance buzzer operates properly (see your -10). Troubleshoot faulty buzzer. Replace unrepairable buzzer (WP 0042 00). e. Check that blower operates properly (see your -10). Troubleshoot faulty blower (WP 0043 00). f. Tape frayed electrical leads. g. Replace damaged connectors (WP 0382 00). 	

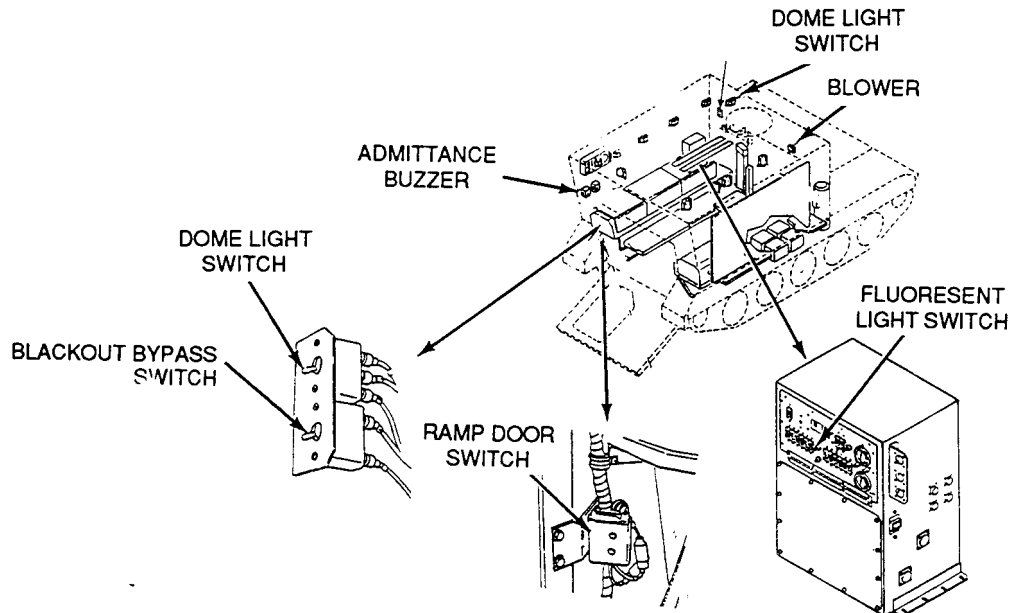

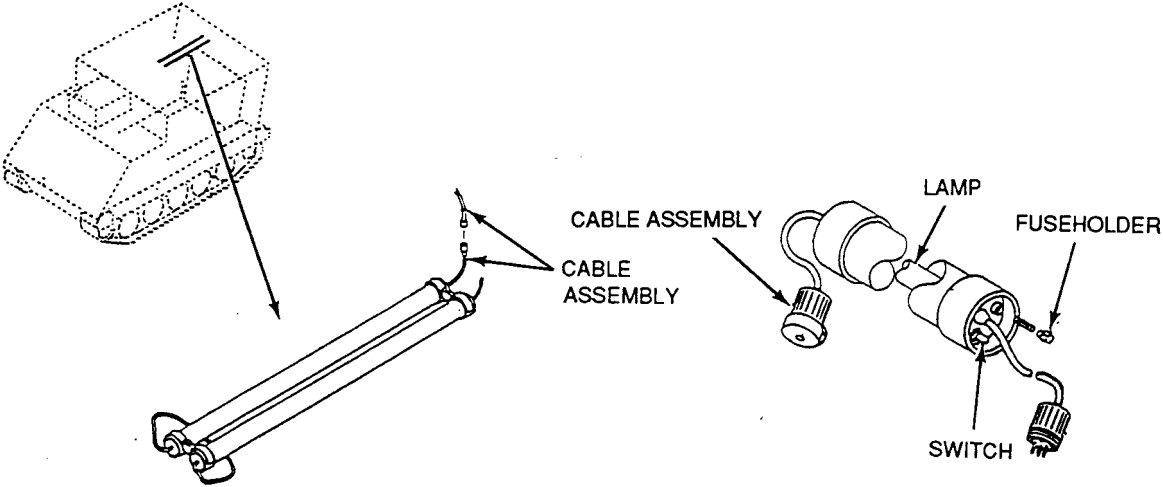

PREVENTIVE MAINTENANCE CHECKS AND SERVICES (PMCS), INCLUDING
LUBRICATION INSTRUCTIONS — Continued

0155 00

ITEM NO.	INTERVAL	MAN-HOUR	ITEM TO BE CHECKED OR SERVICED	CREWMEMBER PROCEDURE	EQUIPMENT NOT READY/AVAILABLE IF:
				<p style="text-align: center;">WARNING</p>  <p>Lethal voltage is present when light set is connected to power source. Disconnect from power source before inspecting or repairing any electrical component. Be careful not to contact electrical connections. Electrical shock and death may result from failure to heed this warning.</p> <p>h. Check cable assembly and their insulations for physical damage. If cable assemblies are damaged, it is necessary to go to a higher level of maintenance.</p> <p>i. Check for security and proper functioning of ON/OFF switch, fuseholder, and lamp. Troubleshoot any faulty elements (WP 0040 00), (WP 0041 00), (WP 0102 00).</p>	
					

**PREVENTIVE MAINTENANCE CHECKS AND SERVICES (PMCS), INCLUDING
LUBRICATION INSTRUCTIONS — Continued**

0155 00

ITEM NO.	INTERVAL	MAN-HOUR	ITEM TO BE CHECKED OR SERVICED	<u>CREWMEMBER</u> PROCEDURE	EQUIPMENT NOT READY/ AVAILABLE IF:
75	Semi-Annual		Driver's Seat	<p>a. Replaced damaged seat components (WP 0551 00).</p> <p>b. Replace seat belts with cuts, frayed, or broken buckle (WP 0552 00).</p> <p style="text-align: center;">WARNING</p> <div style="display: flex; justify-content: center; gap: 20px;">   </div> <p>Seat can spring up and hit you when vertical control handle is released. Make sure you are sitting in the seat before releasing vertical control handle.</p> <p>c. See that seat vertical locking mechanism and horizontal locking mechanism work properly (WP 0552 00, WP 0557 00). Lubricate locking mechanism as needed with OE/HDO.</p>	Any missing, broken, or cracked seat hardware less seat cushions or locking mechanism fail to lock in any position.

PREVENTIVE MAINTENANCE CHECKS AND SERVICES (PMCS), INCLUDING LUBRICATION INSTRUCTIONS — Continued

0155 00

ITEM NO.	INTERVAL	MAN-HOUR	ITEM TO BE CHECKED OR SERVICED	CREWMEMBER PROCEDURE	EQUIPMENT NOT READY/AVAILABLE IF:
76	Semi-Annual		Personnel Seats	<div data-bbox="527 457 1079 1060" data-label="Image"> </div> <p>a. Repair or replace damaged seat cushions (WP 0546 00, WP 0547 00, WP 0548 00).</p> <p>b. Repair or replace cut, broken, or frayed seat belts (WP 0546 00, WP 0547 00, WP 0548 00).</p>	Any missing, broken or cracked seat hardware, less seat cushions or cut, frayed seat belts.
			<div data-bbox="511 1396 1096 1837" data-label="Image"> </div>		

PREVENTIVE MAINTENANCE CHECKS AND SERVICES (PMCS), INCLUDING LUBRICATION INSTRUCTIONS — Continued

0155 00

ITEM NO.	INTERVAL	MAN-HOUR	ITEM TO BE CHECKED OR SERVICED	CREWMEMBER PROCEDURE	EQUIPMENT NOT READY/AVAILABLE IF:
77	Semi-Annual		Commander's Seat (All Except M577A3 and M1068A3)	a. Replaced damaged seat cushions (WP 0561 00). b. Check for smooth operation of seat and vertical locking mechanism as needed with OE/HDO.	Any missing, broken, or cracked seat hardware, less seat cushions, or cut frayed seat belts. Any broken or missing seat and post assembly.

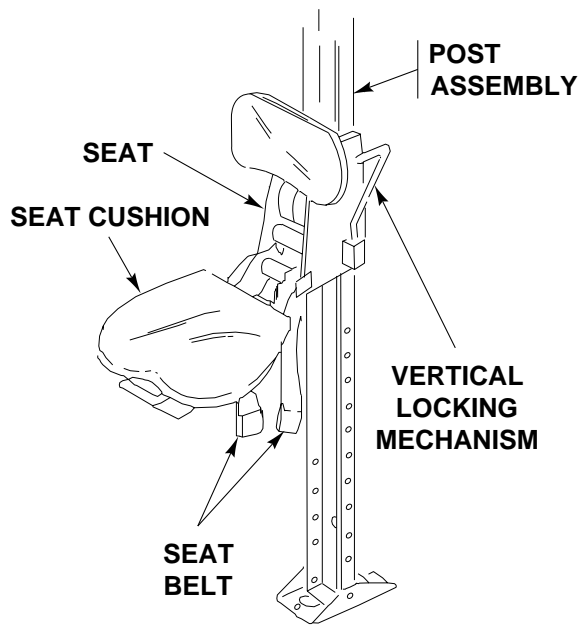

**PREVENTIVE MAINTENANCE CHECKS AND SERVICES (PMCS), INCLUDING
LUBRICATION INSTRUCTIONS — Continued**

0155 00

ITEM NO.	INTERVAL	MAN-HOUR	ITEM TO BE CHECKED OR SERVICED	<u>CREWMEMBER</u> PROCEDURE	EQUIPMENT NOT READY/ AVAILABLE IF:
78	Semi-Annual		Commander's Platform (Except M1059A3)	a. Check platform lock to make sure the platform locks securely in various vertical positions (see your -10). b. Check that platform securing catch and stowing catch work properly (see your -10).	Any missing, broken, or cracked platform hardware, or vertical locking mechanism failing to lock in any position.
79	Semi-Annual		Operator's Seat (M1059A3 and M1068A3)	a. Lubricate locking mechanism and catch as needed with OE/HDO.	

PREVENTIVE MAINTENANCE CHECKS AND SERVICES (PMCS), INCLUDING LUBRICATION INSTRUCTIONS — Continued

0155 00

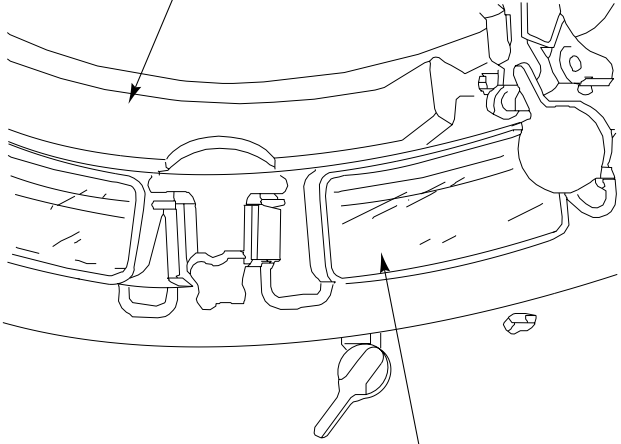
ITEM NO.	INTERVAL	MAN-HOUR	ITEM TO BE CHECKED OR SERVICED	<u>CREWMEMBER</u> PROCEDURE	EQUIPMENT NOT READY/ AVAILABLE IF:
80	Semi-Annual		Commander's Cupola (M113A3, M1064A3 and M1059A3)	<p>a. Replace cut, cracked, or hard cushioning pad. Replace vision blocks that have more than 50 percent impairment (see your -10).</p> <p>b. Replace cracked or chipped vision blocks (WP 0490 00, WP 0491 00).</p> <p>c. Check for smooth rotation of commander's cupola. Replace bearings as required. Notify supervisor.</p> <p>d. For the M1059A3, check bracket and stop. Replace missing or broken parts (WP 0499 00).</p> <div style="text-align: center;"> <p>CUSHIONING PAD</p>  <p>VISION BLOCKS</p> </div>	
81	Semi-Annual		Data Plates, Decals, Stencils, and Markers	<p>a. Replace missing or damaged data plates, decals, stencils, and markers (WP 0654 00).</p>	

PREVENTIVE MAINTENANCE CHECKS AND SERVICES (PMCS), INCLUDING LUBRICATION INSTRUCTIONS — Continued

0155 00

ITEM NO.	INTERVAL	MAN-HOUR	ITEM TO BE CHECKED OR SERVICED	CREWMEMBER PROCEDURE	EQUIPMENT NOT READY/ AVAILABLE IF:
82	Semi-Annual		Black-Out Curtain (M577A3 & M1068A3 Only)	a. Repair or replace blackout curtain that is torn or worn thin (WP 0629 00). b. Replace blackout curtain that has torn or missing straps (WP 0629 00). c. Replace broken or missing fasteners (WP 0629 00).	

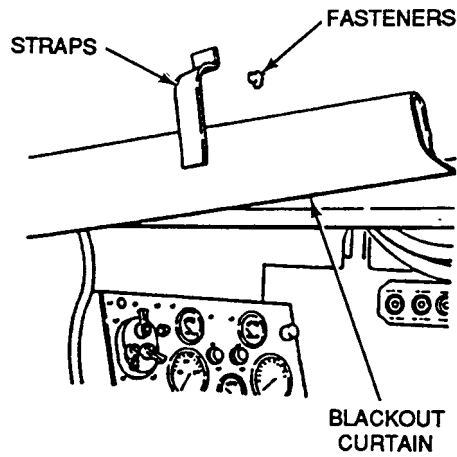

PREVENTIVE MAINTENANCE CHECKS AND SERVICES (PMCS), INCLUDING LUBRICATION INSTRUCTIONS — Continued

0155 00

ITEM NO.	INTERVAL	MAN-HOUR	ITEM TO BE CHECKED OR SERVICED	CREWMEMBER PROCEDURE	EQUIPMENT NOT READY/ AVAILABLE IF:
83	Semi-Annual		Map Tables and Map Board (M577A3 Only)	a. Tighten or replace loose or missing screws on map tables and supports. b. Replace map table or map board that is badly damaged or warped (WP 0578 00), (WP 0580 00) , (WP 0581 00), (WP 0582 00).	
<p>The diagram shows a perspective view of a map board assembly. A 'BLACKOUT CURTAIN' is shown at the top left. Below it, a 'MAP BOARD' is mounted on 'SUPPORTS'. The supports are connected to a 'SHELF' which is attached to a 'WORK SURFACE' at the bottom. Arrows point from each label to the corresponding part of the assembly.</p>					
84	Semi-Annual		Map Board, Rack Bases, Shelf Assembly, and Work Surfaces (M1068A3)	a. Tighten or replace loose or missing screws on work surface, supports, map board, and shelf assembly. b. Replace badly damaged map boards and work surfaces (WP 0618 00).	

PREVENTIVE MAINTENANCE CHECKS AND SERVICES (PMCS), INCLUDING LUBRICATION INSTRUCTIONS — Continued

0155 00

ITEM NO.	INTERVAL	MAN-HOUR	ITEM TO BE CHECKED OR SERVICED	CREWMEMBER PROCEDURE	EQUIPMENT NOT READY/ AVAILABLE IF:
85	Semi-Annual		Tents and Stowage Brackets (M577A3 & M1068A3 Only)	<p>a. Replace tent that has tears, breaks, fraying, or other damage (WP 0627 00), (WP 0628 00), and TM 10-5410-229-13&P.</p> <p>b. Tighten screws on mounting clamps and strip.</p>	
86	Semi-Annual		4.2 KW Generator Set Enclosure (M577A3 and M1068A3 Only)	<p>a. Tighten or replace loose or missing screws on enclosure to 55-60 lb-ft (75-81 N·m) torque. Use torque wrench (WP 0926 00, Item 82).</p> <p>b. Replace damaged enclosure (WP 0674 00).</p>	

PREVENTIVE MAINTENANCE CHECKS AND SERVICES (PMCS), INCLUDING LUBRICATION INSTRUCTIONS — Continued

0155 00

ITEM NO.	INTERVAL	MAN-HOUR	ITEM TO BE CHECKED OR SERVICED	CREWMEMBER PROCEDURE	EQUIPMENT NOT READY/AVAILABLE IF:
87	Semi-Annual		5.0 KW Auxiliary Power Unit (APU) (M577A3 and M1068A3 Only)	a. See TM9-6115-664-13&P for PMCS procedures. Replace damaged APU (WP 0675 00).	

AUXILIARY POWER UNIT (5.0 KW APU) (M1068A3 & M577A3 ONLY)

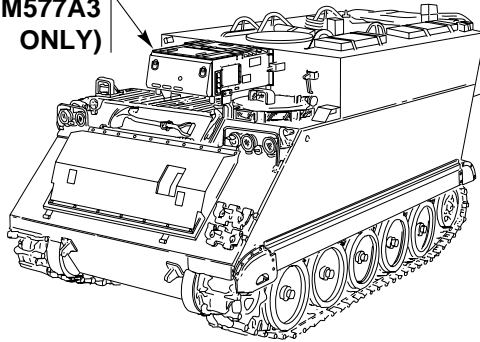

PREVENTIVE MAINTENANCE CHECKS AND SERVICES (PMCS), INCLUDING LUBRICATION INSTRUCTIONS — Continued

0155 00

ITEM NO.	INTERVAL	MAN-HOUR	ITEM TO BE CHECKED OR SERVICED	CREWMEMBER PROCEDURE	EQUIPMENT NOT READY/AVAILABLE IF:
88	Semi-Annual		Capstan Drum and Adapter (M113A3 and M1059A3)	<p>a. Check capstan drum and adapter. Replace cracked or damaged drum or adapter. Tighten loose screws or retainer.</p> <p>b. If retainer can be unscrewed from drum, replace spring pin.</p>	

The diagram illustrates the capstan drum and adapter assembly. The upper portion shows a side view of a tank with a callout line pointing to the capstan drum on the top deck. The lower portion is a detailed technical drawing of the capstan drum and adapter assembly. It shows a cylindrical drum with a central hub, an adapter plate with several screws, and a retainer ring. Labels with arrows point to 'SCREWS', 'DRUM', 'ADAPTER', and 'RETAINER'.

**PREVENTIVE MAINTENANCE CHECKS AND SERVICES (PMCS), INCLUDING
LUBRICATION INSTRUCTIONS — Continued**

0155 00

ITEM NO.	INTERVAL	MAN-HOUR	ITEM TO BE CHECKED OR SERVICED	<u>CREWMEMBER</u> PROCEDURE	EQUIPMENT NOT READY/ AVAILABLE IF:
89	Semi-Annual		Litter Kit	<ul style="list-style-type: none"> a. Perform preventive maintenance checks and services every 750 miles (1207 km), 75 hours, semiannually, or whichever comes first. b. Check hangar. Replace hangar if cracked or if threads are stripped (WP 0744 00). c. Check three repair links. Replace cracked links (WP 0745 00). d. Check chain. Replace chain if links are broken (WP 0744 00). e. Check two litter straps. Replace straps if torn or if buckles are damaged (WP 0743 00). f. Check two litter hooks. Replace hooks if cracked or if they can't be recurved to hold litters (WP 0745 00). 	

PREVENTIVE MAINTENANCE CHECKS AND SERVICES (PMCS), INCLUDING LUBRICATION INSTRUCTIONS — Continued

0155 00

ITEM NO.	INTERVAL	MAN-HOUR	ITEM TO BE CHECKED OR SERVICED	<u>CREWMEMBER</u> PROCEDURE	EQUIPMENT NOT READY/ AVAILABLE IF:
				<p>g. Check chain. Replace chain if links are broken (WP 0744 00).</p> <p>h. Check S hooks. Replace damaged S hooks (WP 0745 00).</p> <p>i. Check helical spring. Replace cracked spring (WP 0745 00).</p> <p>j. Check chain hook. Replace hook if cracked (WP 0745 00) or if they can't be recurved.</p>	

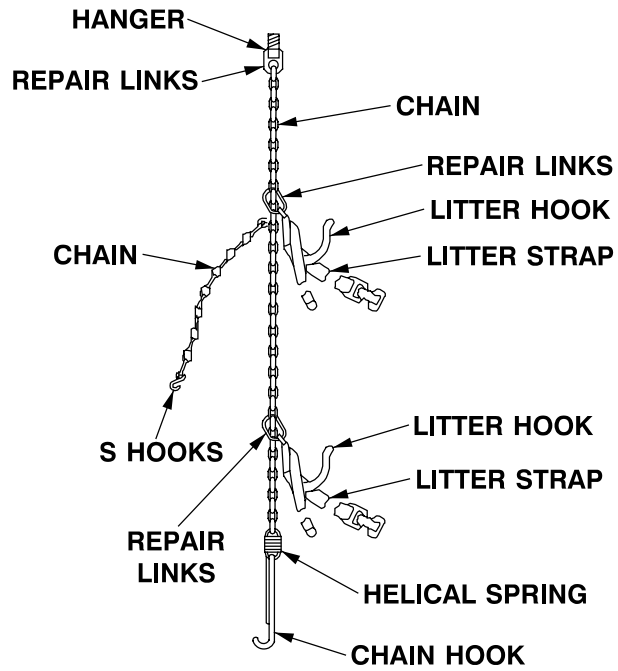
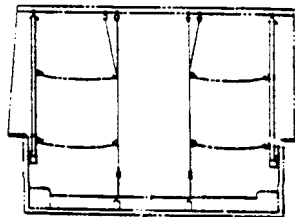

PREVENTIVE MAINTENANCE CHECKS AND SERVICES (PMCS), INCLUDING LUBRICATION INSTRUCTIONS — Continued

0155 00

ITEM NO.	INTERVAL	MAN-HOUR	ITEM TO BE CHECKED OR SERVICED	CREWMEMBER PROCEDURE	EQUIPMENT NOT READY/AVAILABLE IF:
				<p>k. Check posts. Straighten bent posts. Replace cracked posts (WP 0742 00).</p> <p>l. Check drive screw. Make sure it holds bead chain securely. Replace loose screw (WP 0745 00).</p> <p>m. Check bead chain. Replace broken chain (WP 0745 00).</p> <p>n. Check spring pin. Replace loose pin (WP 0742 00).</p> <p>o. Check litter support. Replace post if support is cracked (WP 0742 00).</p> <p>p. Check strap. Replace strap if torn or if buckles are damaged (WP 0743 00).</p> <p>q. Check bracket, screws, and washers. Replace loose or missing parts (WP 0741 00).</p>	

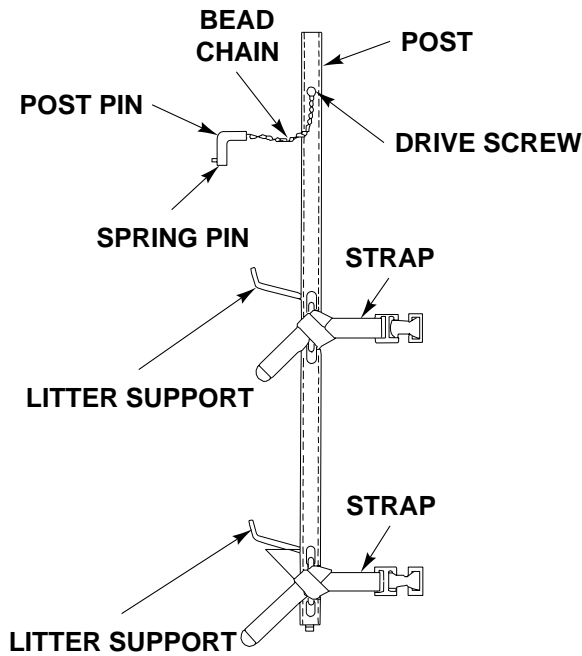

PREVENTIVE MAINTENANCE CHECKS AND SERVICES (PMCS), INCLUDING LUBRICATION INSTRUCTIONS — Continued

0155 00

ITEM NO.	INTERVAL	MAN-HOUR	ITEM TO BE CHECKED OR SERVICED	<u>CREWMEMBER</u> PROCEDURE	EQUIPMENT NOT READY/ AVAILABLE IF:
				<p>r. Check two litter hooks. Replace hooks if cracked or if they can't be recurved to hold litters (WP 0745 00).</p> <p>s. Check chain. Replace chain links if they are broken (WP 0745 00).</p> <p>t. Check S hooks. Replace damaged S hooks (WP 0745 00).</p> <p>u. Check helical spring. Replace cracked spring (WP 0745 00).</p> <p>v. Check chain hooks. Replace hook if cracked or if it can't be recurved (WP 0745 00).</p>	

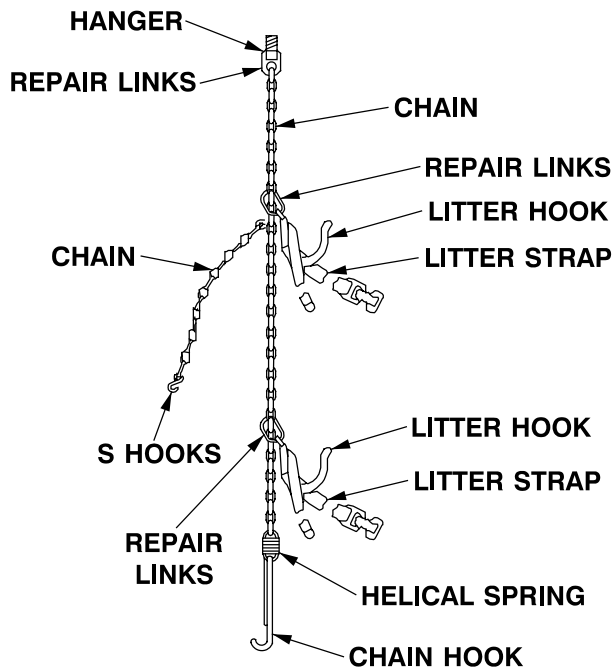

PREVENTIVE MAINTENANCE CHECKS AND SERVICES (PMCS), INCLUDING LUBRICATION INSTRUCTIONS — Continued

0155 00

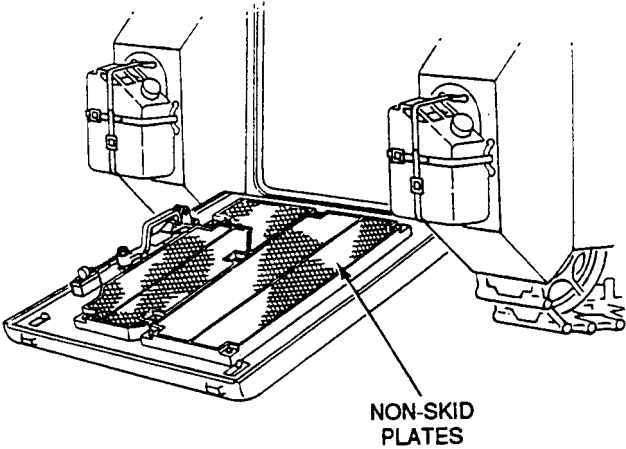
ITEM NO.	INTERVAL	MAN-HOUR	ITEM TO BE CHECKED OR SERVICED	CREWMEMBER PROCEDURE	EQUIPMENT NOT READY/AVAILABLE IF:
90	Semi-Annual		Ramp Non-Skid Winterization Kit (M1064A3 Only)	a. Check non-skid plates for cracks. Tighten loose mounting plate bolts. Replace cracked plates (WP 0738 00).	
					
91	Semi-Annual	0.4	Carrier	a. Lubricate steering control lever and shaft bearings. <p style="text-align: center;">NOTE</p> <p>When grease fittings will not accept GAA, notify your supervisor.</p> <ol style="list-style-type: none"> 1) Every 150 hours/1500 miles or semi-annually, lubricate bearings with GAA through fitting at each end of steering support and power plant bulkhead. Use grease gun with flexible adapter. See Steering Control Bearing Lubrication Table (Table 8, page 0155 00-23). 2) Clean fittings with cleaning compound (WP 0928 00, Item 19) prior to lubrication. Check/lubricate grease fitting points after washing or fording. 	

**PREVENTIVE MAINTENANCE CHECKS AND SERVICES (PMCS), INCLUDING
LUBRICATION INSTRUCTIONS — Continued**

0155 00

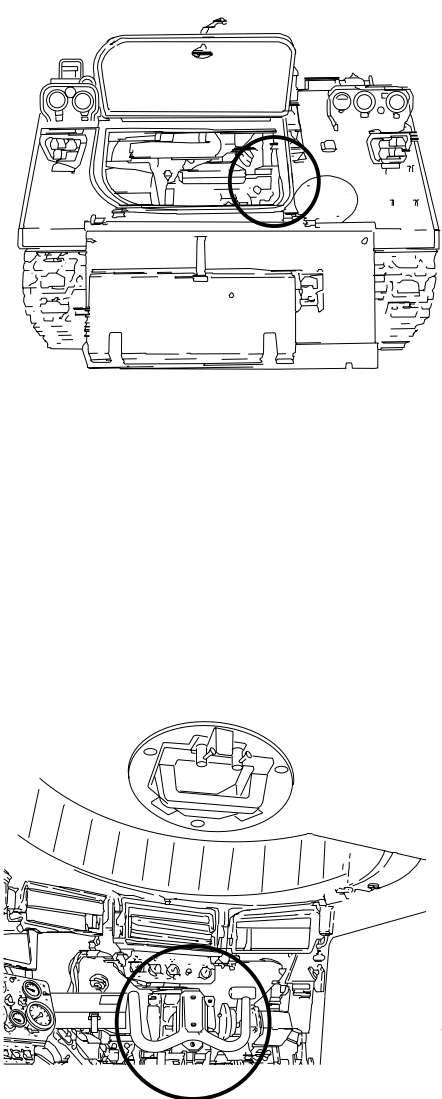
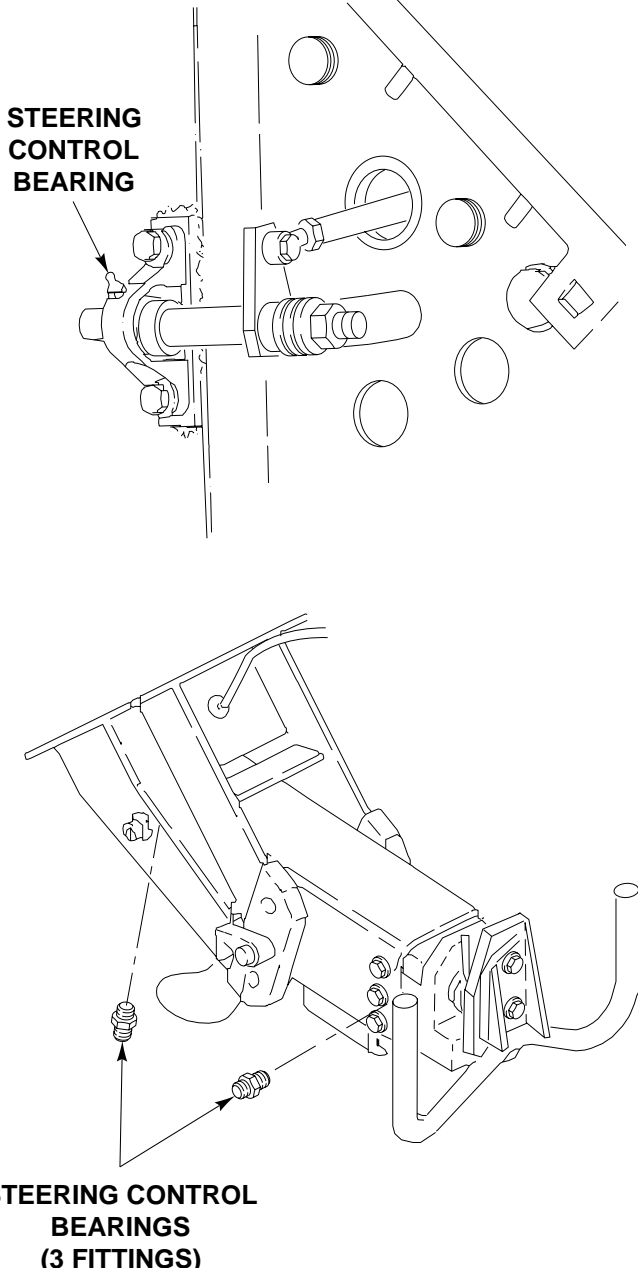
ITEM NO.	INTERVAL	MAN-HOUR	ITEM TO BE CHECKED OR SERVICED	CREWMEMBER PROCEDURE	EQUIPMENT NOT READY/AVAILABLE IF:
					

PREVENTIVE MAINTENANCE CHECKS AND SERVICES (PMCS), INCLUDING LUBRICATION INSTRUCTIONS — Continued

0155 00

ITEM NO.	INTERVAL	MAN-HOUR	ITEM TO BE CHECKED OR SERVICED	CREWMEMBER PROCEDURE	EQUIPMENT NOT READY/ AVAILABLE IF:
92	Semi-Annual		NBC Mounting Hardware Kit	a. Check mounts. Replace worn, weak, or cracked mounts. b. Tighten loose mounting screws and nuts. c. Check webstraps securing NBC hoses properly.	

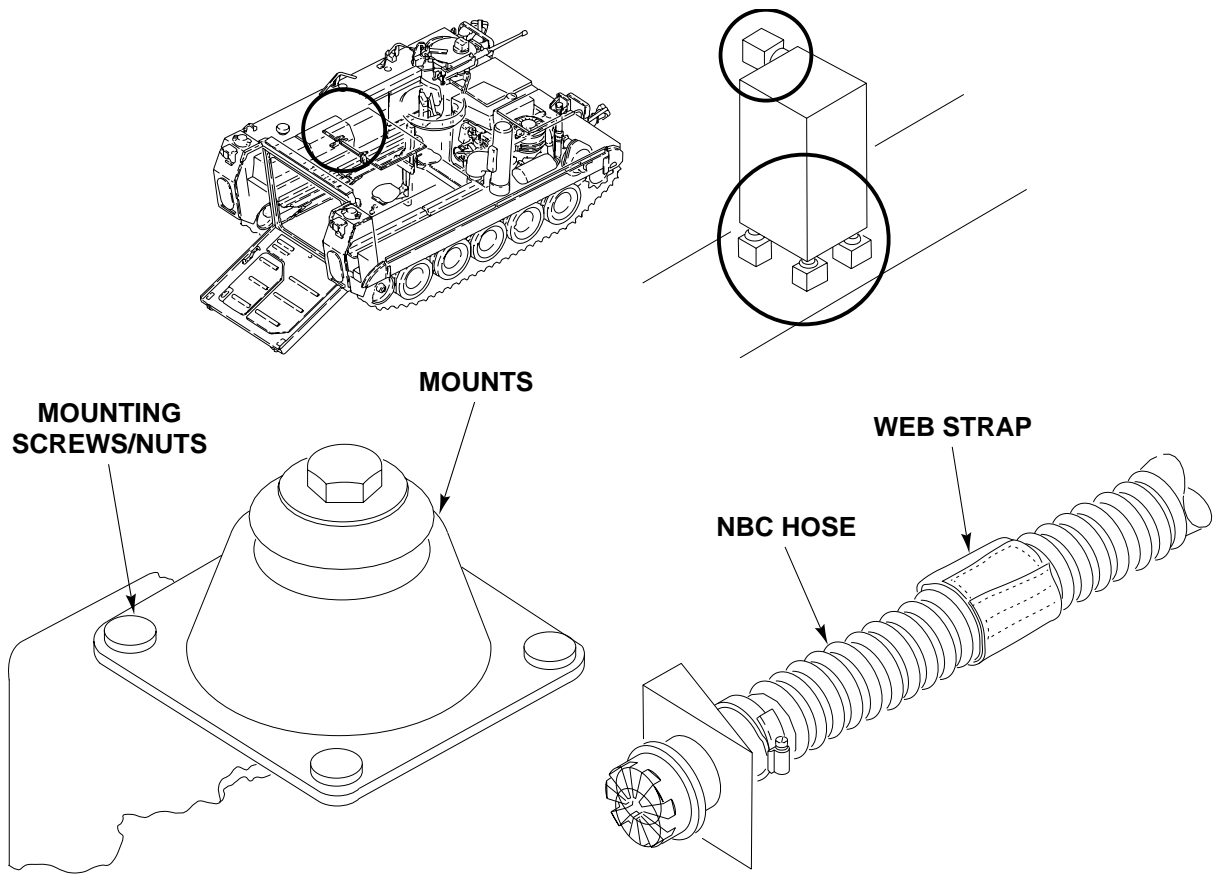

**PREVENTIVE MAINTENANCE CHECKS AND SERVICES (PMCS), INCLUDING
LUBRICATION INSTRUCTIONS — Continued**

0155 00

ITEM NO.	INTERVAL	MAN-HOUR	ITEM TO BE CHECKED OR SERVICED	<u>CREWMEMBER</u> PROCEDURE	EQUIPMENT NOT READY/ AVAILABLE IF:
93	Semi-Annual		Gas Particulate Filter	<p style="text-align: center;">NOTE</p> <p>Refer to TM 3-6680-316-10 for use of the M39 tester.</p> <p>a. Slide spring clip away from slotted openings of precleaner (blower) assembly and set MASTER switch and NBC POWER switch to ON (blower must function).</p> <p>b. Remove calibrated orifice assembly from airflow tester (6650-00-436-4212) and zero magnetic gauge.</p> <p>c. Disconnect crew member hose (for station being tested) from container in vehicle and attach connector to calibrated orifice assembly connector of airflow tester.</p> <p style="text-align: center;">NOTE</p> <p>An acceptable gauge reading is between 2.6 and 4.3 inches of water.</p> <p>d. If reading is not within limits, note reading. See TM 3-6680-316-10.</p> <p>e. Connect crew member hose to vehicle connection. Set MASTER switch and NBC POWER switch to OFF and recover slotted holes in precleaner (blower) assembly with spring clip.</p> <p style="text-align: center;">NOTE</p> <p>Refer repair of particulate filter to direct maintenance personnel per TM 3-4240-276-30 and TM 3-4240-276-30P.</p>	

PREVENTIVE MAINTENANCE CHECKS AND SERVICES (PMCS), INCLUDING LUBRICATION INSTRUCTIONS — Continued

0155 00

ITEM NO.	INTERVAL	MAN-HOUR	ITEM TO BE CHECKED OR SERVICED	CREWMEMBER PROCEDURE	EQUIPMENT NOT READY/AVAILABLE IF:
94	Semi-Annual		Chemical Agent Automatic Alarm Kit (M113A3 Only)	a. Perform preventive maintenance checks and services every 750 miles (1,207 km), 75 hours, or semiannually, whichever comes first. b. Cable maintenance is limited to replacement of terminals (WP 0919 00). c. Remove distribution box from hull (WP 0269 00). Check terminal board and circuit breaker. Tighten loose connection. Install distribution box on hull (WP 0269 00).	

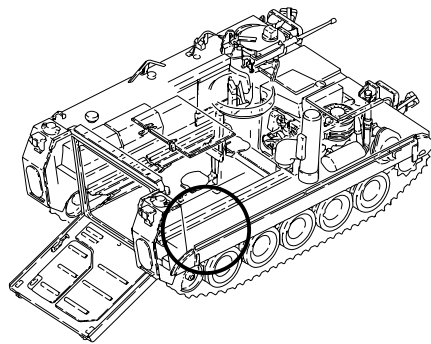

CIRCUIT BREAKER

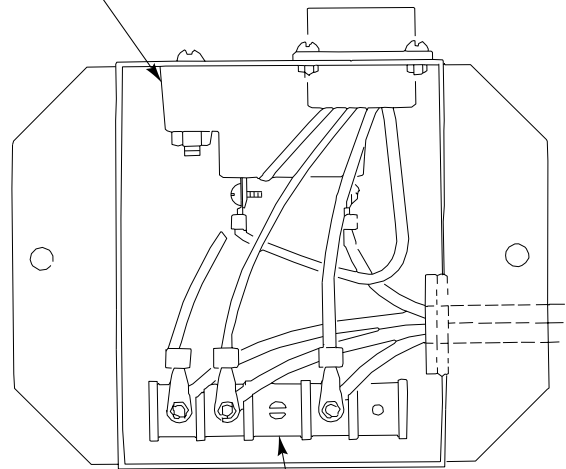

TERMINAL BOARD

**PREVENTIVE MAINTENANCE CHECKS AND SERVICES (PMCS), INCLUDING
LUBRICATION INSTRUCTIONS — Continued**

0155 00

ITEM NO.	INTERVAL	MAN-HOUR	ITEM TO BE CHECKED OR SERVICED	<u>CREWMEMBER</u> PROCEDURE	EQUIPMENT NOT READY/ AVAILABLE IF:
				<p style="text-align: center;">NOTE</p> <p>Additional data on chemical Agent Automatic Alarm Kit for the M113 FOV can be found in:</p> <p>Operator's and Unit Manual TM 3-6665-224-12</p> <p>Repair Parts and Special Tools List TM 9-2350-277-24P</p> <p>d. Check mounting screws on junction box. Tighten loose screws in junction box. Tighten loose screws to 72 lb-in (8 N·m) torque. Use torque wrench (WP 0926 00, Item 79) and socket set (WP 0926 00, Item 72).</p> <p>e. Check grommet. Replace cracked or worn grommet.</p> <p>f. Check cable and circuit breaker terminal. Tighten loose connections. Replace damaged terminals.</p> <p>g. Check cables. Replace frayed or cracked cables (WP 0919 00).</p>	

PREVENTIVE MAINTENANCE CHECKS AND SERVICES (PMCS), INCLUDING LUBRICATION INSTRUCTIONS — Continued

0155 00

ITEM NO.	INTERVAL	MAN-HOUR	ITEM TO BE CHECKED OR SERVICED	<u>CREWMEMBER</u> PROCEDURE	EQUIPMENT NOT READY/ AVAILABLE IF:
----------	----------	----------	--------------------------------	--------------------------------	---------------------------------------

CIRCUIT BREAKER TERMINALS

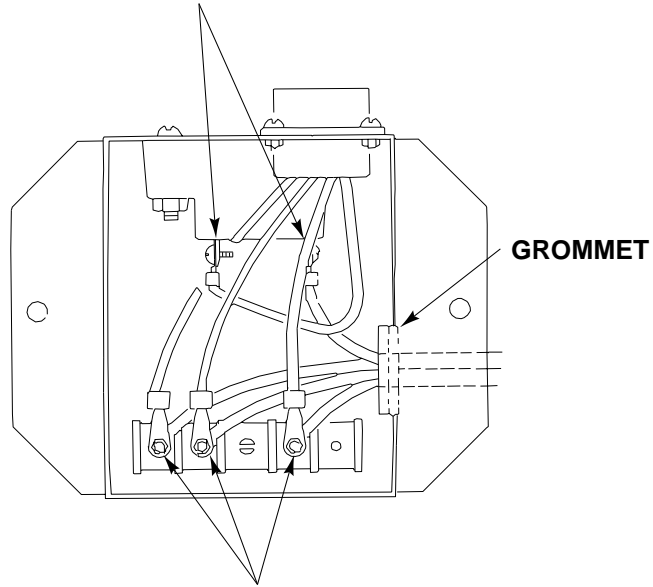

CABLE TERMINAL

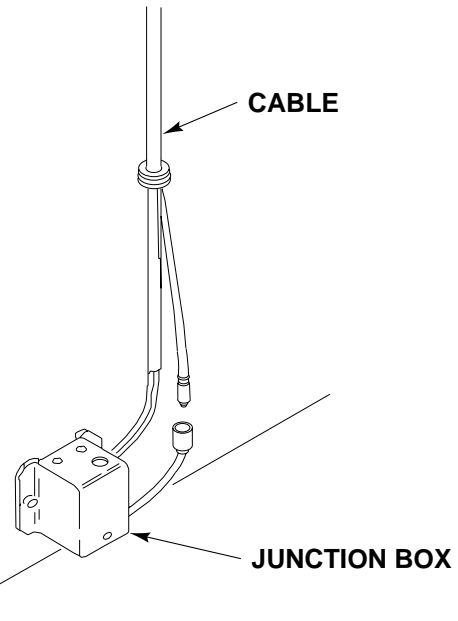
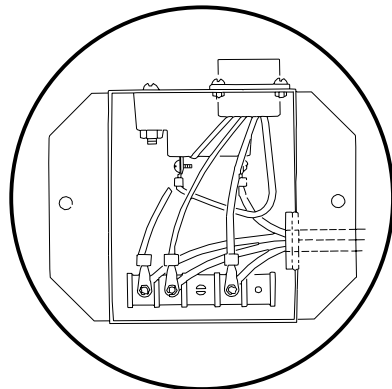

h. Check brackets. Replace cracked or broken brackets.

PREVENTIVE MAINTENANCE CHECKS AND SERVICES (PMCS), INCLUDING LUBRICATION INSTRUCTIONS — Continued

0155 00

ITEM NO.	INTERVAL	MAN-HOUR	ITEM TO BE CHECKED OR SERVICED	<u>CREWMEMBER</u> PROCEDURE	EQUIPMENT NOT READY/ AVAILABLE IF:
				<p>i. Check mounting screws. Tighten loose screws. Tighten screws to 264-285 lb-in (30-32 N-m) torque. Use torque wrench (WP 0926 00, Item 81) and socket set (WP 0926 00, Item 72).</p> <p>j. Check straps. Replace worn straps.</p>	

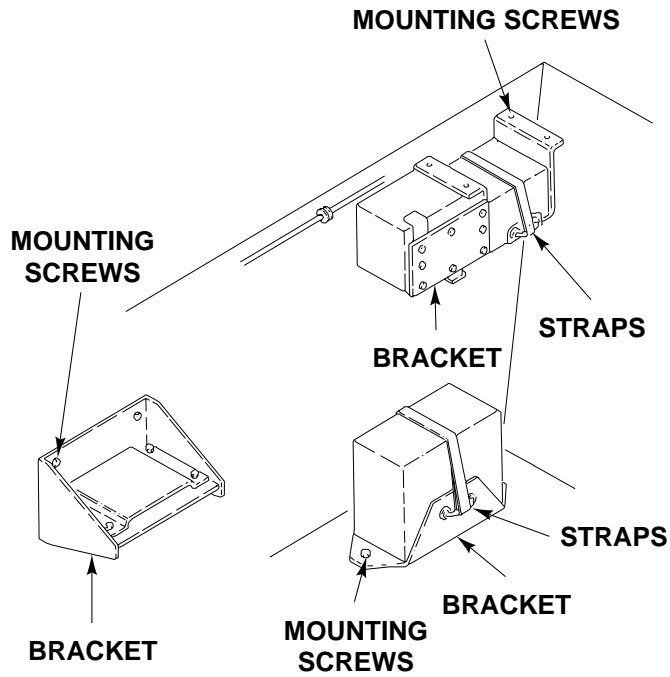

PREVENTIVE MAINTENANCE CHECKS AND SERVICES (PMCS), INCLUDING LUBRICATION INSTRUCTIONS — Continued

0155 00

ITEM NO.	INTERVAL	MAN-HOUR	ITEM TO BE CHECKED OR SERVICED	CREWMEMBER PROCEDURE	EQUIPMENT NOT READY/ AVAILABLE IF:
95	Semi-Annual		Engine Coolant Heater Kit	a. Perform preventive maintenance checks every 750 miles (1,207 km), 75 hours, or semiannually whichever comes first. b. Tighten mounting screws and clamps. c. Check heater inlet for debris. d. Check pump for leaks. Tighten connections that leak.	Any fuel, coolant, or exhaust leaks.

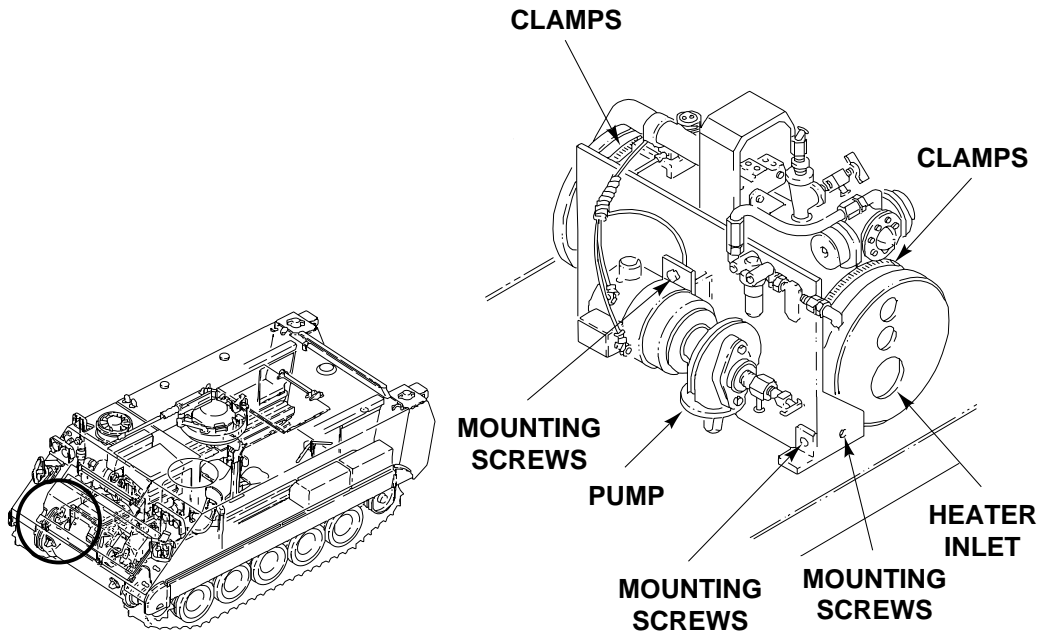

PREVENTIVE MAINTENANCE CHECKS AND SERVICES (PMCS), INCLUDING LUBRICATION INSTRUCTIONS — Continued

0155 00

ITEM NO.	INTERVAL	MAN-HOUR	ITEM TO BE CHECKED OR SERVICED	<u>CREWMEMBER</u> PROCEDURE	EQUIPMENT NOT READY/ AVAILABLE IF:
----------	----------	----------	--------------------------------	--------------------------------	---------------------------------------

e. Check heat exchanger and hose connections for leaks. Tighten connections that leak. Replace connections that continue to leak.

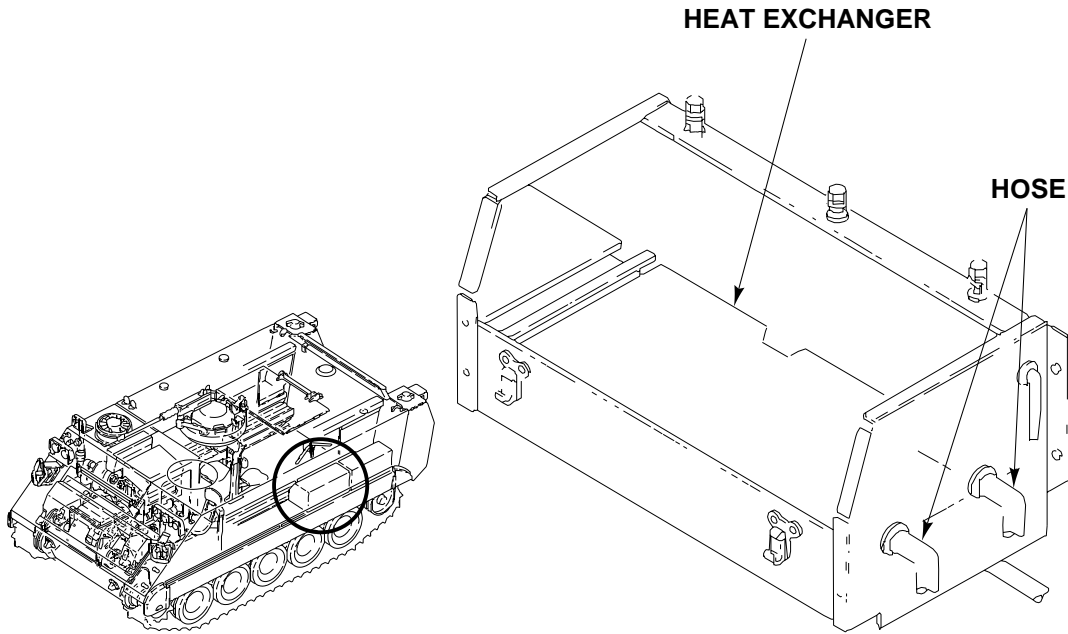

f. Check hose. Replace damaged hose (WP 0725 00).

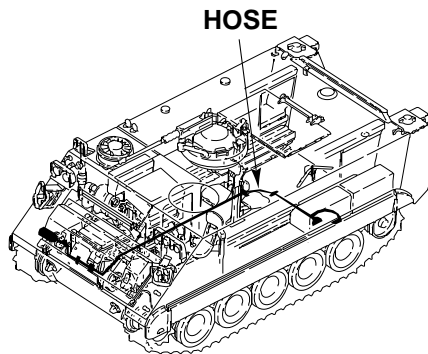

PREVENTIVE MAINTENANCE CHECKS AND SERVICES (PMCS), INCLUDING LUBRICATION INSTRUCTIONS — Continued

0155 00

ITEM NO.	INTERVAL	MAN-HOUR	ITEM TO BE CHECKED OR SERVICED	<u>CREWMEMBER</u> PROCEDURE	EQUIPMENT NOT READY/ AVAILABLE IF:
				<p>g. Check clamps and mount flange for exhaust leaks. Tighten clamp. Replace bad flange gaskets (WP 0724 00).</p> <p>h. Check exhaust pipe. Replace cracked or damaged pipe (WP 0724 00).</p>	

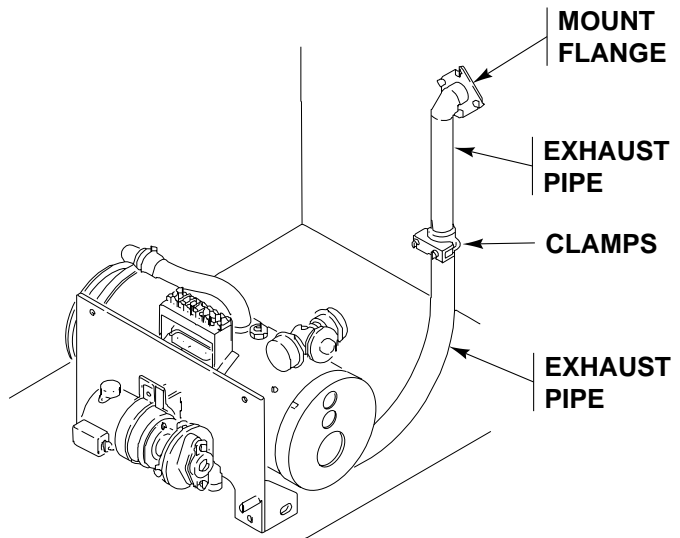
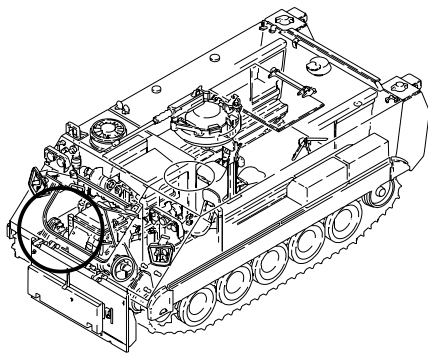

PREVENTIVE MAINTENANCE CHECKS AND SERVICES (PMCS), INCLUDING LUBRICATION INSTRUCTIONS — Continued

0155 00

ITEM NO.	INTERVAL	MAN-HOUR	ITEM TO BE CHECKED OR SERVICED	<u>CREWMEMBER</u> PROCEDURE	EQUIPMENT NOT READY/ AVAILABLE IF:
				i. Check fuel hoses, other hose connections and fuel pump for leaks. Tighten connections that leak. Replace connections that continue to leak. j. Service fuel pump (WP 0709 00). k. Tighten fuel pump mounting screws.	

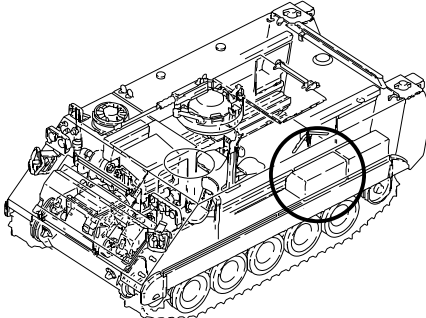
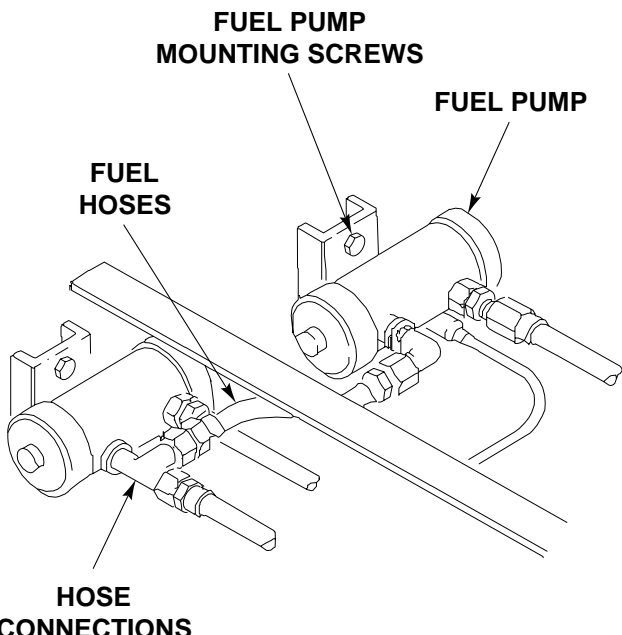
**PREVENTIVE MAINTENANCE CHECKS AND SERVICES (PMCS), INCLUDING
LUBRICATION INSTRUCTIONS — Continued**

0155 00

ITEM NO.	INTERVAL	MAN-HOUR	ITEM TO BE CHECKED OR SERVICED	<u>CREWMEMBER</u> PROCEDURE	EQUIPMENT NOT READY/ AVAILABLE IF:
				l. Check electrical leads and connectors at heater, at control box and at fuel pump. Tape frayed leads. Replace damaged connectors (WP 0382 00). m. Check heater control box, switches and light bulbs. Tighten or replace bad switches and bulbs (WP 0702 00). n. Start, run and stop heater (see your -10). During start cycle, verify that switches and lights work properly. o. During operation, check for unusual noises. Check for increase in coolant temperature. p. When stopping heater, check for correct purge cycle. Verify that indicator lights properly. If heater does not operate as specified above, perform troubleshooting (WP 0089 00).	Heater fails to cycle for proper shutdown.

**PREVENTIVE MAINTENANCE CHECKS AND SERVICES (PMCS), INCLUDING
LUBRICATION INSTRUCTIONS — Continued**

0155 00

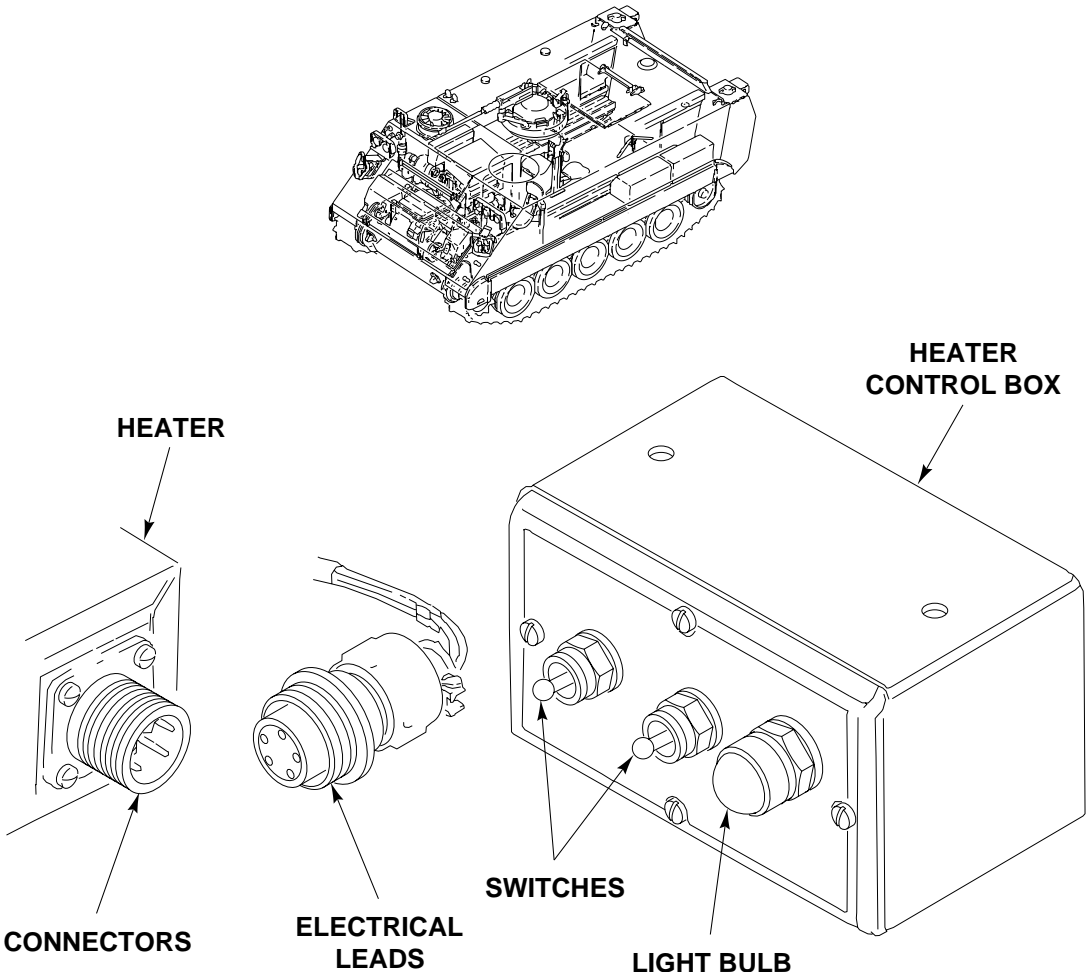
ITEM NO.	INTERVAL	MAN-HOUR	ITEM TO BE CHECKED OR SERVICED	<u>CREWMEMBER</u> PROCEDURE	EQUIPMENT NOT READY/ AVAILABLE IF:
			 <p>The diagram shows a tracked vehicle at the top. Below it are detailed views of the heater system components: a heater unit with callouts for 'HEATER', 'CONNECTORS', and 'ELECTRICAL LEADS'; and a 'HEATER CONTROL BOX' with callouts for 'SWITCHES' and 'LIGHT BULB'.</p>		

PREVENTIVE MAINTENANCE CHECKS AND SERVICES (PMCS), INCLUDING
LUBRICATION INSTRUCTIONS — Continued

0155 00

ITEM NO.	INTERVAL	MAN-HOUR	ITEM TO BE CHECKED OR SERVICED	CREWMEMBER PROCEDURE	EQUIPMENT NOT READY/ AVAILABLE IF:
<p>The diagram illustrates the electrical and fuel system components for a heater. It is divided into two parts. The upper part shows a rectangular 'HEATER CONTROL BOX' with three electrical terminals on its front panel. A 'CONNECTOR' is shown plugged into the rightmost terminal, with 'ELECTRICAL LEADS' extending from it. The lower part shows a 'FUEL PUMP' assembly mounted on a metal bracket. It features two electrical terminals. 'ELECTRICAL LEADS' are shown connected to these terminals, with 'CONNECTORS' at the connection points.</p>					

PREVENTIVE MAINTENANCE CHECKS AND SERVICES (PMCS), INCLUDING LUBRICATION INSTRUCTIONS — Continued

0155 00

ITEM NO.	INTERVAL	MAN-HOUR	ITEM TO BE CHECKED OR SERVICED	<u>CREWMEMBER</u> PROCEDURE	EQUIPMENT NOT READY/ AVAILABLE IF:
96	Semi-Annual		Commander's Cupola Armor Shield (M113A3 and M1064A3 Only)	a. Check left and right armor shield. Repair or replace cracked shield. If welds are cracked, notify supervisor (WP 0747 00). b. Check doors and clips. Straighten dents and bends. Replace cracked door or clip (WP 0747 00). c. Replace stowage strap or clamp if damaged (WP 0747 00).	

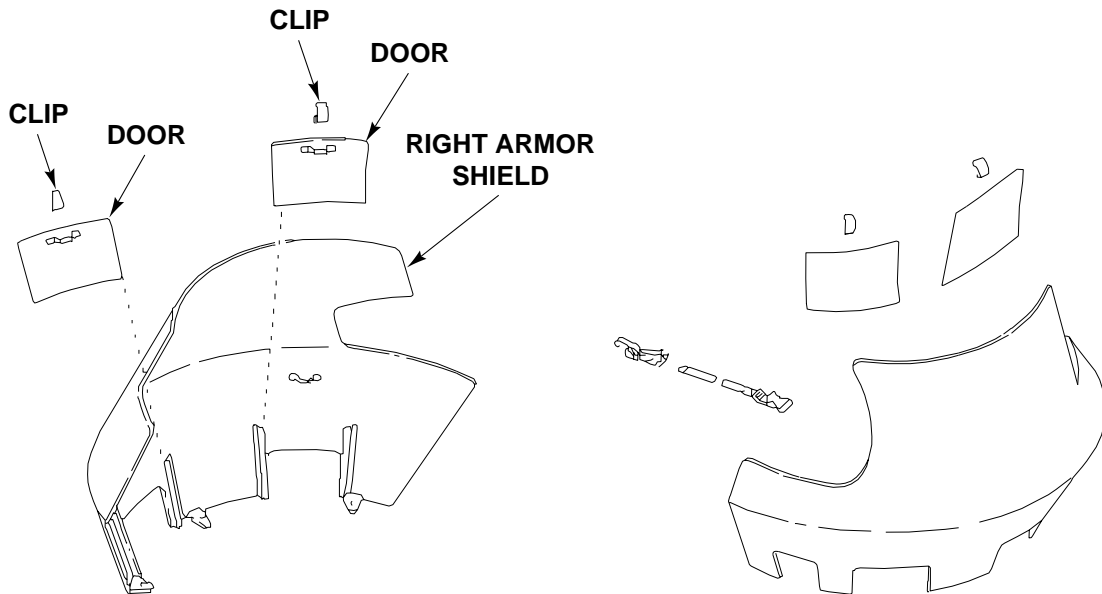
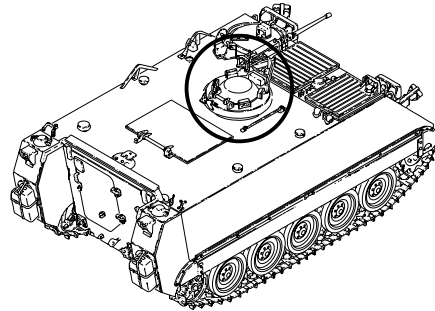

**PREVENTIVE MAINTENANCE CHECKS AND SERVICES (PMCS), INCLUDING
LUBRICATION INSTRUCTIONS — Continued**

0155 00

ITEM NO.	INTERVAL	MAN-HOUR	ITEM TO BE CHECKED OR SERVICED	<u>CREWMEMBER</u> PROCEDURE	EQUIPMENT NOT READY/ AVAILABLE IF:
				d. Check periscope door and door bracket on machine gun mount. e. Straighten dents and bends. Replace cracked parts.	

PREVENTIVE MAINTENANCE CHECKS AND SERVICES (PMCS), INCLUDING LUBRICATION INSTRUCTIONS — Continued

0155 00

ITEM NO.	INTERVAL	MAN-HOUR	ITEM TO BE CHECKED OR SERVICED	<u>CREWMEMBER PROCEDURE</u>	EQUIPMENT NOT READY/AVAILABLE IF:
97	Semi-Annual		Personnel Heater Kit	a. Tighten loose mounting screws and clamps. b. Remove control cover by turning two screws to the left.	Any fuel, coolant, or exhaust leaks.

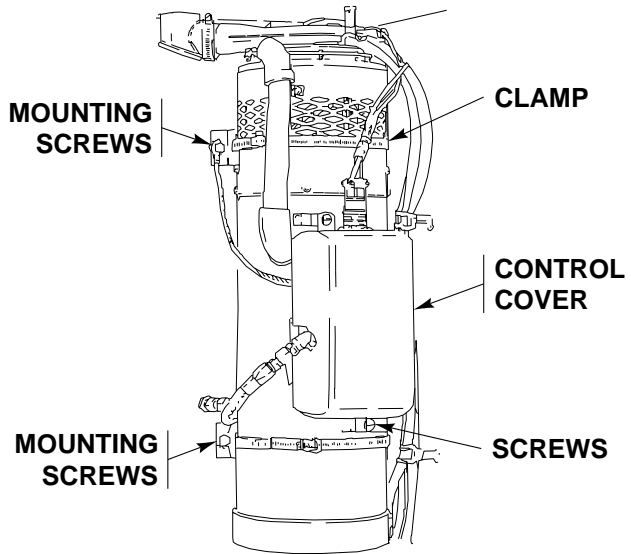
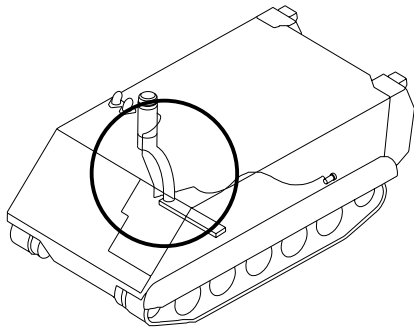

PREVENTIVE MAINTENANCE CHECKS AND SERVICES (PMCS), INCLUDING LUBRICATION INSTRUCTIONS — Continued

0155 00

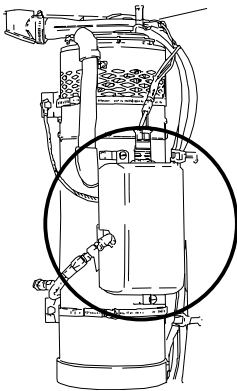
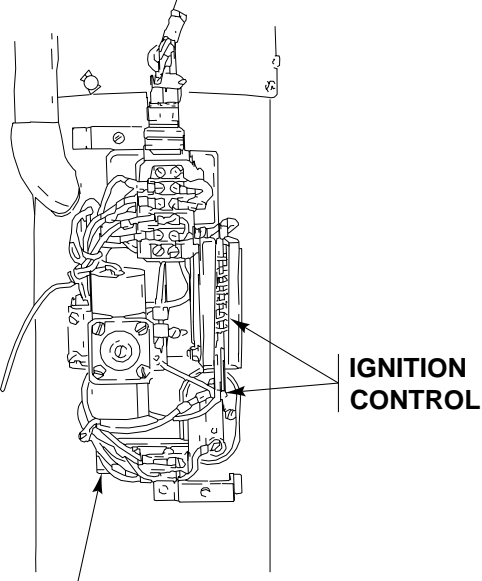
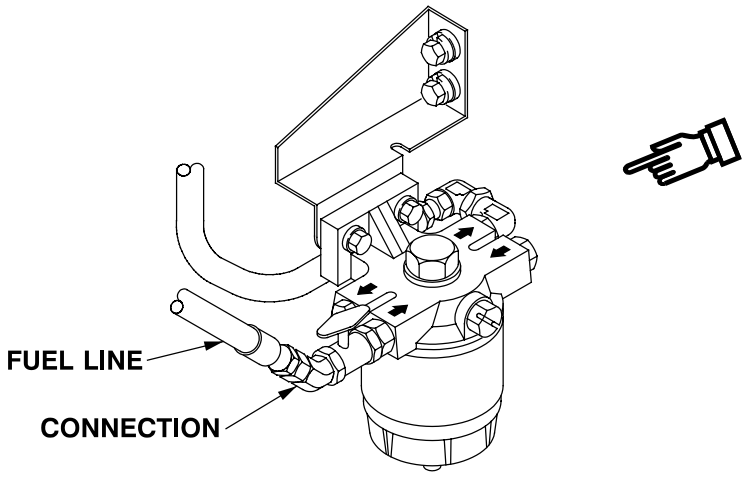
ITEM NO.	INTERVAL	MAN-HOUR	ITEM TO BE CHECKED OR SERVICED	CREWMEMBER PROCEDURE	EQUIPMENT NOT READY/AVAILABLE IF:
			 <p style="text-align: center;">FLAME DETECTOR SWITCH</p>	<p>c. Check flame detector switch and ignition control (TM 9-2450-205-24&P for models 10560M24B1 and D55350-G1; see TM 9-2340-207-14&P for model 5000-30178).</p>  <p style="text-align: center;">IGNITION CONTROL</p>	
			 <p style="text-align: center;">FUEL LINE CONNECTION</p>	<p>d. Check heater fuel pump, fuel lines, and connections for leaks. Replace connections that continue to leak.</p>	

**PREVENTIVE MAINTENANCE CHECKS AND SERVICES (PMCS), INCLUDING
LUBRICATION INSTRUCTIONS — Continued**

0155 00

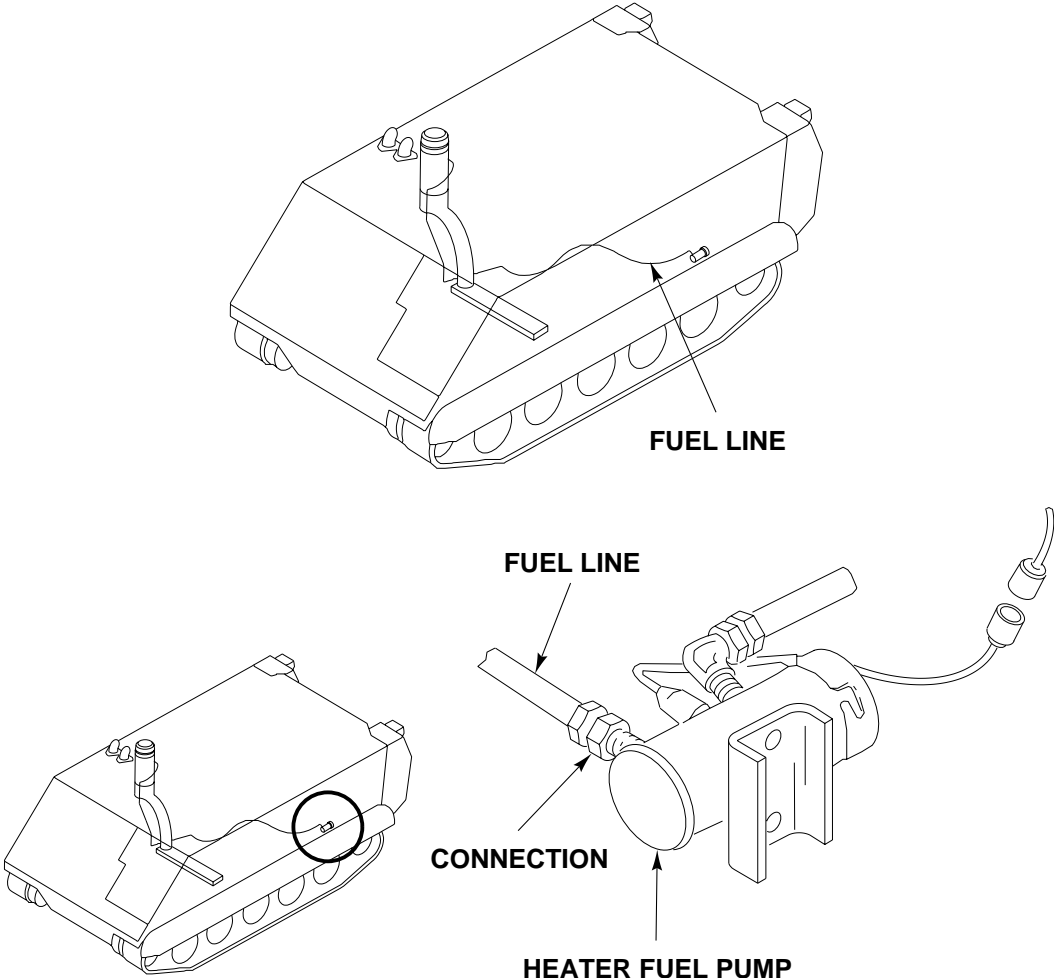
ITEM NO.	INTERVAL	MAN-HOUR	ITEM TO BE CHECKED OR SERVICED	<u>CREWMEMBER</u> PROCEDURE	EQUIPMENT NOT READY/ AVAILABLE IF:
			 <p>The diagram shows a fuel tank with a fuel line extending from the top. A heater fuel pump assembly is connected to the fuel line. The fuel line is labeled 'FUEL LINE'. The connection between the fuel line and the heater fuel pump is labeled 'CONNECTION'. The heater fuel pump is labeled 'HEATER FUEL PUMP'.</p>		

PREVENTIVE MAINTENANCE CHECKS AND SERVICES (PMCS), INCLUDING LUBRICATION INSTRUCTIONS — Continued

0155 00

ITEM NO.	INTERVAL	MAN-HOUR	ITEM TO BE CHECKED OR SERVICED	CREWMEMBER PROCEDURE	EQUIPMENT NOT READY/AVAILABLE IF:
				e. Check for signs of exhaust leaks. Tighten clamps.	

PREVENTIVE MAINTENANCE CHECKS AND SERVICES (PMCS), INCLUDING LUBRICATION INSTRUCTIONS — Continued

0155 00

ITEM NO.	INTERVAL	MAN-HOUR	ITEM TO BE CHECKED OR SERVICED	<u>CREWMEMBER</u> PROCEDURE	EQUIPMENT NOT READY/ AVAILABLE IF:
				f. Check electrical leads and connectors at heater, at heater control box and at fuel pump. Tape leads if frayed. Replace damaged connectors (WP 0701 00).	

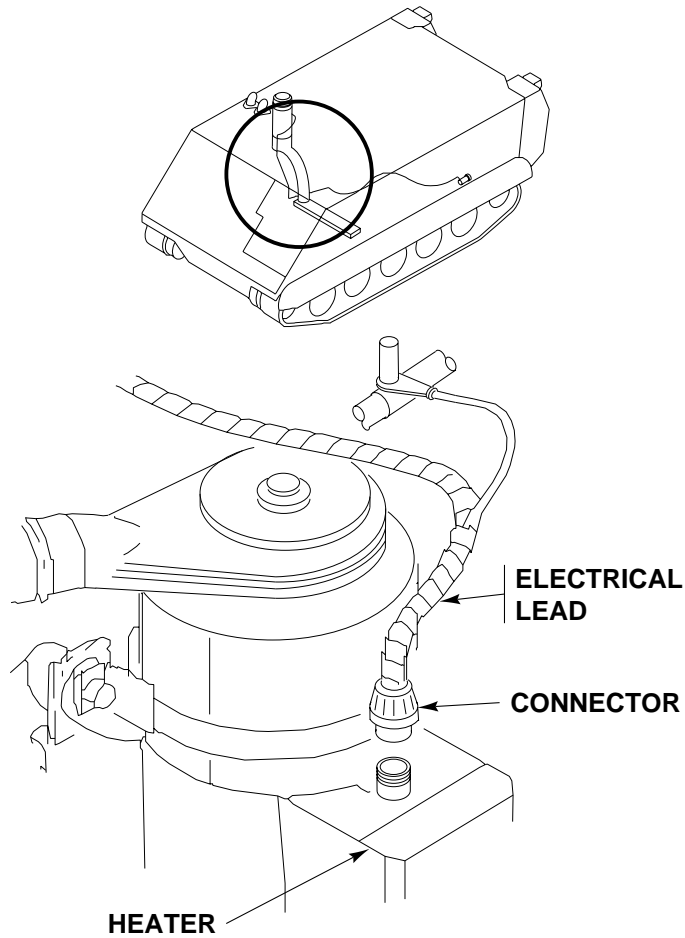

PREVENTIVE MAINTENANCE CHECKS AND SERVICES (PMCS), INCLUDING
LUBRICATION INSTRUCTIONS — Continued

0155 00

ITEM NO.	INTERVAL	MAN-HOUR	ITEM TO BE CHECKED OR SERVICED	CREWMEMBER PROCEDURE	EQUIPMENT NOT READY/AVAILABLE IF:
<p>The diagram illustrates the electrical wiring for a fuel pump system. It features a central control box with a circular opening on its side. Two electrical leads are connected to the control box: one enters from the top left, and another enters from the right. The lead on the right is labeled 'ELECTRICAL LEAD' and is connected to a 'CONNECTOR' on the control box. This connector is further linked to a 'FUEL PUMP' assembly. The fuel pump assembly includes a cylindrical component and a bracket. Two 'ELECTRICAL LEADS' are shown connected to the fuel pump assembly. The top left lead is labeled 'ELECTRICAL LEAD' and is connected to a 'CONNECTOR'. The bottom right lead is labeled 'ELECTRICAL LEADS' and is connected to another 'CONNECTOR'. The control box is labeled 'CONTROL BOX'. The fuel pump is labeled 'FUEL PUMP'. The diagram uses arrows to point to the various components and their connections.</p>					

PREVENTIVE MAINTENANCE CHECKS AND SERVICES (PMCS), INCLUDING LUBRICATION INSTRUCTIONS — Continued

0155 00

ITEM NO.	INTERVAL	MAN-HOUR	ITEM TO BE CHECKED OR SERVICED	<u>CREWMEMBER</u> PROCEDURE	EQUIPMENT NOT READY/ AVAILABLE IF:
				<p>g. Check heater control box, switches, and light bulb. Tighten or replace bad switches and bulbs (WP 0702 00).</p> <p>h. Start, run, and stop heater (see your -10). During start cycle, check that switches and light work properly. Check for increase in blower speed after ignition.</p> <p>i. During operation, check for unusual noises. Check for differences between high and low heat levels.</p> <p>j. When stopping heater, check for correct purge cycle. Verify that indicator light operates properly. If heater does not operate as specified above, perform troubleshooting (WP 0086 00).</p>	

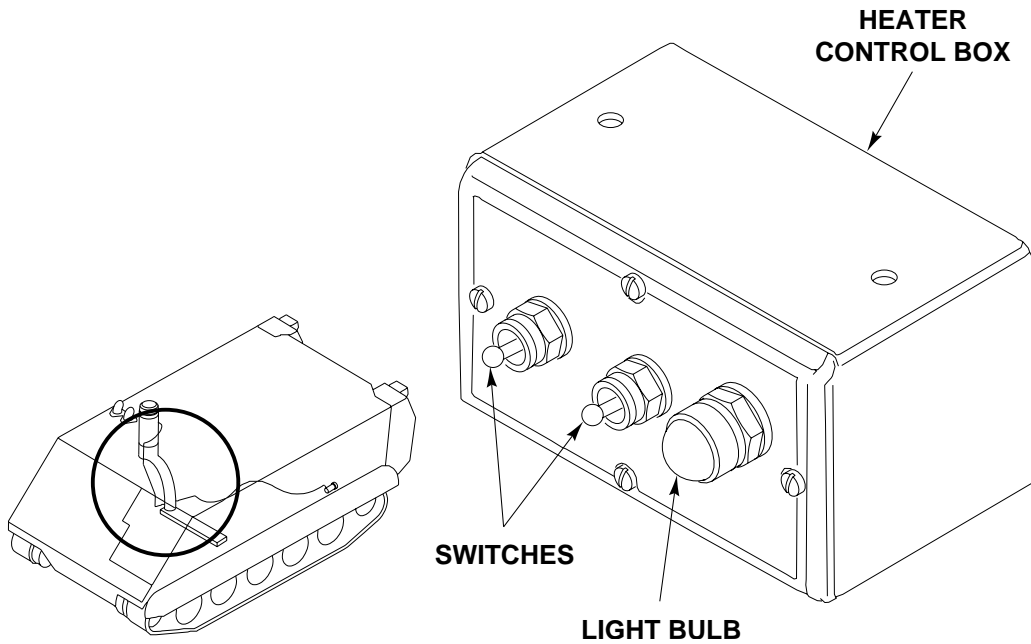

PREVENTIVE MAINTENANCE CHECKS AND SERVICES (PMCS), INCLUDING LUBRICATION INSTRUCTIONS — Continued

0155 00

ITEM NO.	INTERVAL	MAN-HOUR	ITEM TO BE CHECKED OR SERVICED	CREWMEMBER PROCEDURE	EQUIPMENT NOT READY/ AVAILABLE IF:
98	Semi-Annual		Driver's Windshield Kit	a. Clean windshield with clean water. Check windows. Replace cracked or chipped windshield (WP 0739 00). b. Check windshield. Replace windshield that has broken or missing legs. c. Check mounting bracket and plates. Replace damaged brackets and plates. d. Check windshield canvas. Repair tears with sealing tape (WP 0928 00, Item 39) or replace windshield.	

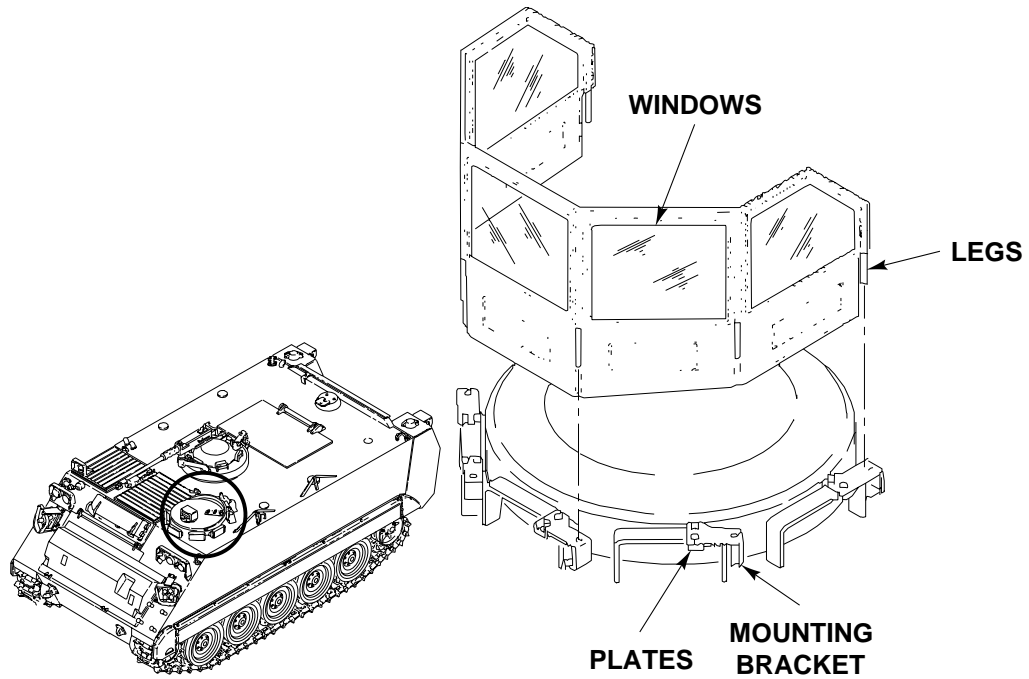

PREVENTIVE MAINTENANCE CHECKS AND SERVICES (PMCS), INCLUDING LUBRICATION INSTRUCTIONS — Continued

0155 00

ITEM NO.	INTERVAL	MAN-HOUR	ITEM TO BE CHECKED OR SERVICED	<u>CREWMEMBER</u> PROCEDURE	EQUIPMENT NOT READY/ AVAILABLE IF:
99	Semi-Annual		Turn Signal Lights, Stop Lights, Blackout Stop Lights, Dome Lights, Fluorescent Lights and Switches	a. Test operation of lights with signal control in all four operating positions. Repair or replace damaged or discolored lenses. Repair or replace defective lights, control, flasher and lights.	
100	Semi-Annual		Reflectors	Check reflectors lens. Replace damaged or missing lens.	
101	Semi-Annual		Electrical Wiring	a. Tighten electrical connections and mounting brackets. Tape frayed harness. Replace missing or damaged connectors.	
102	Semi-Annual		Slave Cable	<p style="text-align: center;">NOTE</p> <p style="text-align: center;">Location varies by model.</p> <p>a. Check the slave cable receptacle and cap for damage, burnt condition and corrosion.</p>	
103	Semi-Annual		Transmission/ Engine Spline Drive	<p>a. Perform M113A3 Detection procedures for wear signs on the transmission/engine spline drive coupling as follows:</p> <p style="text-align: center;">NOTE</p> <p style="text-align: center;">Spline drive coupling wear can be detected in its early stages using any of the following three inspection procedures. For best results, use all three.</p>	
a	Semi-Annual		Transmission/ Engine Spline Drive (first check)	<p>a. The first type of inspection is the power method. This method is strictly audio based.</p> <p>b. To check the spline drive coupling, fully pull out the fuel cut-off control from the driver's position, so fuel can not get to the engine and it will not start. Dry start the engine for 4-6 seconds.</p>	Metallic clanking sound is heard.

PREVENTIVE MAINTENANCE CHECKS AND SERVICES (PMCS), INCLUDING LUBRICATION INSTRUCTIONS — Continued

0155 00

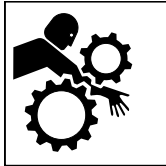
ITEM NO.	INTERVAL	MAN-HOUR	ITEM TO BE CHECKED OR SERVICED	<u>CREWMEMBER</u> PROCEDURE	EQUIPMENT NOT READY/ AVAILABLE IF:
b	Semi-Annual		Transmission/ Engine Spline Drive (second check)	<p>c. The sound produced from a good spline drive coupling is muffled, and can be heard as the engine is cranking. The sound is muffled because the external spline on the spline drive ring is nylon coated. When the nylon coating, which is only 13 to 20 thousandths of an inch thick, on the spline drive ring is good, it will mate tightly with the engine's internal spline teeth and produce a muffled sound. The sound produced from a worn-out spline drive coupling is a very distinct metallic clanking sound that can be easily heard as the engine is cranking. When the nylon coating on the spline drive ring is worn-out, it engages in a metal to metal backlash with the flywheel's internal spline teeth which are uncoated. This causes the metallic clanking sound.</p> <p>a. The second type of inspection is the manual audio method.</p> <div style="text-align: center;"> <p>WARNING</p>  </div> <p>Fuel cut-off control at driver's position must be pulled all the way out to prevent engine from starting. Personnel could be injured or killed if engine starts during this PMCS check.</p> <p>b. Loosen the three wing nuts and clamps to remove the engine's rear access panel from the crew compartment. This will access the engine's variable drive assembly pulley.</p> <p>c. The pulley has three jacking bolt holes with 3/8" coarse thread. Hand tighten two 3/8" by 3" long bolts into the jacking holes.</p>	Metallic clanking sound is heard.

PREVENTIVE MAINTENANCE CHECKS AND SERVICES (PMCS), INCLUDING LUBRICATION INSTRUCTIONS — Continued

0155 00

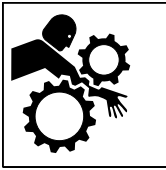
ITEM NO.	INTERVAL	MAN-HOUR	ITEM TO BE CHECKED OR SERVICED	<u>CREWMEMBER</u> PROCEDURE	EQUIPMENT NOT READY/ AVAILABLE IF:
c	Semi-Annual		Transmission/ Engine Spline Drive (third check)	<p>d. Place a small breaker bar, about 2 or 3 feet long, across the two bolts to check backlash on the spline drive coupling.</p> <p style="text-align: center;">NOTE</p> <p>Although you can turn the engine by applying constant pressure, the idea is to detect any backlash generated between the engine and transmission mating splines.</p> <p>e. As with the power method, a good spline drive coupling will produce a muffled sound, while a bad spline drive coupling will produce a distinctive metallic clanking sound.</p> <p>a. The third type of inspection is the visual method.</p> <p style="text-align: center;">WARNING</p> <div style="text-align: center;">  </div> <p>Fuel cut-off control at driver's position must be pulled all the way out to prevent engine from starting. Personnel could be injured or killed if engine starts during this PMCS check.</p> <p>b. Two people are required to perform the visual method. One will be inside the vehicle manually jerking the engine. Meanwhile the second will be under the vehicle observing the relative motion between the flywheel's clearance holes and the spline drive ring's studs and nuts.</p>	Studs and nuts are not centered (approximately 1/4 inch) in flywheel clearance holes.

**PREVENTIVE MAINTENANCE CHECKS AND SERVICES (PMCS), INCLUDING
LUBRICATION INSTRUCTIONS — Continued**

0155 00

ITEM NO.	INTERVAL	MAN-HOUR	ITEM TO BE CHECKED OR SERVICED	<u>CREWMEMBER</u> PROCEDURE	EQUIPMENT NOT READY/ AVAILABLE IF:
				<ul style="list-style-type: none"> c. Remove the four bolts, washers and gasket from the access cover under the vehicle directly under the powerpack. d. Push the hydraulic hoses to the side and look into the access opening. You will see the rear bottom side of the engine's flywheel cover as well as a 2'' by 3'' opening on the flywheel cover in the six o'clock location. e. On a sharp angle through this opening, you will see the back side of the flywheel, as well as the clearance holes on the flywheel but through the opening you can only see one hole at a time. f. Looking at the clearance holes, you can also see the studs and locking nuts that hold the spline drive ring in place. The spline drive ring studs and nuts are designed to protrude into the flywheel's clearance holes and clear the flywheel's holes by approximately 1/4''. g. As in the audio method, use the 3/8'' bolts and the breaker bar to detect any backlash. Turn the engine manually to position one of the flywheel's clearance holes in the center of the flywheel's cover opening for visual accessibility. h. As the person in the crew compartment moves the engine, the person under the vehicle looking into the access hole will be able to detect one of the following two relative movements on the spline drive coupling. <ul style="list-style-type: none"> 1) When the spline drive coupling is in good condition, you can only detect unit movements because the clearance between the mating spline teeth is just a few thousandths of an inch. 	

**PREVENTIVE MAINTENANCE CHECKS AND SERVICES (PMCS), INCLUDING
LUBRICATION INSTRUCTIONS — Continued**

0155 00

ITEM NO.	INTERVAL	MAN-HOUR	ITEM TO BE CHECKED OR SERVICED	<u>CREWMEMBER</u> PROCEDURE	EQUIPMENT NOT READY/ AVAILABLE IF:
				<p style="text-align: center;">NOTE</p> <p>Remember that when the nylon coating on the spline drive ring teeth is new or in good condition, the clearance between the spline drive ring and the flywheel internal spline is only a few thousandths of an inch.</p> <p>2) When the spline drive coupling is worn-out, you will be able to detect the individual movement between the spline drive ring studs and nuts and flywheels's clearance holes. This movement is due to the actual wear of the spline teeth. The more the wear, the more the movement.</p> <p>i. If you should hear the metallic clanking sound, as mentioned in any one of the above inspection procedures, immediately notify your direct support maintenance or supervisor</p> <p>j. Using these three methods, you will easily be able to tell the difference between the muffled sound of a good spline drive coupling and the metallic clanking of a bad spline drive coupling. Detecting wear of the kind in it's early stages will reduce down time and keep your M113A3 ready for action.</p>	

**PREVENTIVE MAINTENANCE CHECKS AND SERVICES (PMCS), INCLUDING
LUBRICATION INSTRUCTIONS — Continued**

0155 00

ITEM NO.	INTERVAL	MAN-HOUR	ITEM TO BE CHECKED OR SERVICED	<u>CREWMEMBER</u> PROCEDURE	EQUIPMENT NOT READY/ AVAILABLE IF:
104	Semi-Annual		Final Road Test	a. Perform final carrier road test. Drive carrier at least 5 miles (8 km). b. Ensure correction of operation faults. Pay close attention to those items that were faulty to begin with.	Any Class III leaks or operational faults.
a	Semi-Annual		Left and Right Steering	<p style="text-align: center;"><u>CAUTION</u></p> <p>Power plant can be damaged. Do not pivot steer when carrier is moving except on a track failure emergency.</p> a. Check steering in left or right turns. If carrier doesn't finish a complete turn when wheel is turned right or left, troubleshoot steering system (WP 0076 00, WP 0077 00).	
b	Semi-Annual		Steering in Forward and Reverse	a. Check steering in forward and reverse. If carrier doesn't finish a complete turn when wheel is turned right or left, troubleshoot steering system (WP 0076 00, WP 0077 00).	
c	Semi-Annual		Carrier Braking	a. If carrier doesn't slow down with brake pedal slightly pressed or stop when pedal is fully depressed, troubleshoot brake selection system (WP 0064 00).	
d	Semi-Annual		Carrier Shifting in All Ranges	a. Check shifting of carrier in all ranges. If carrier doesn't respond properly to selected driving range, troubleshoot gear system (WP 0065 00).	

PREVENTIVE MAINTENANCE CHECKS AND SERVICES (PMCS), INCLUDING
LUBRICATION INSTRUCTIONS — Continued

0155 00

Table 19. Annual Unit Level Preventive Maintenance Checks and Services for M113A3 FOV

ITEM NO.	INTERVAL	MAN-HOUR	ITEM TO BE CHECKED OR SERVICED	CREWMEMBER PROCEDURE	EQUIPMENT NOT READY/AVAILABLE IF:
105	Annual	0.1	Carrier	<p>a. Lubricate tachometer and speedometer shafts annually with GIA. See Tachometer and Speedometer Shaft Lubrication Table (Table 11, page 0155 00-26).</p> <p>1) Disconnect shafts at both ends (WP 0432 00), remove slotted washers from drive ends of cores, and remove cores from instrument panel end of shafts. Clean and lubricate cores with GIA, insert cores in shafts. Install slotted washers, and connect both end of shafts. If tachometer adapter has a grease fitting, lubricate sparingly with lubricant GIA.</p> <p>b. Clean, inspect and lubricate cores. Insert cores in shafts. Install slotted washers and connect both ends of shafts. If tachometer adapter has a grease fitting, lubricate sparingly with GIA.</p>	

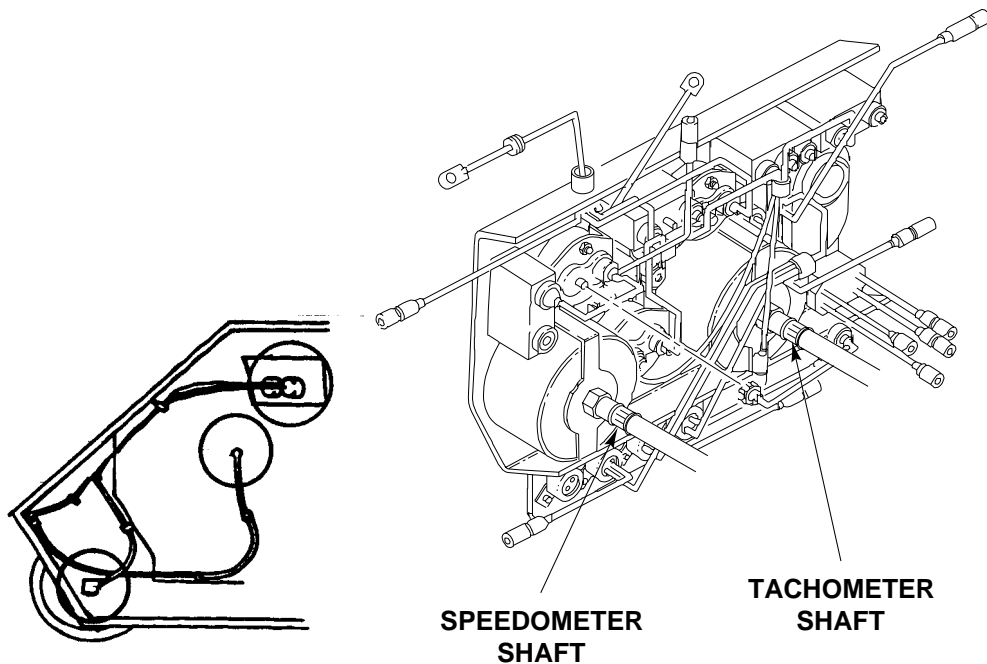

**PREVENTIVE MAINTENANCE CHECKS AND SERVICES (PMCS), INCLUDING
LUBRICATION INSTRUCTIONS — Continued**

0155 00

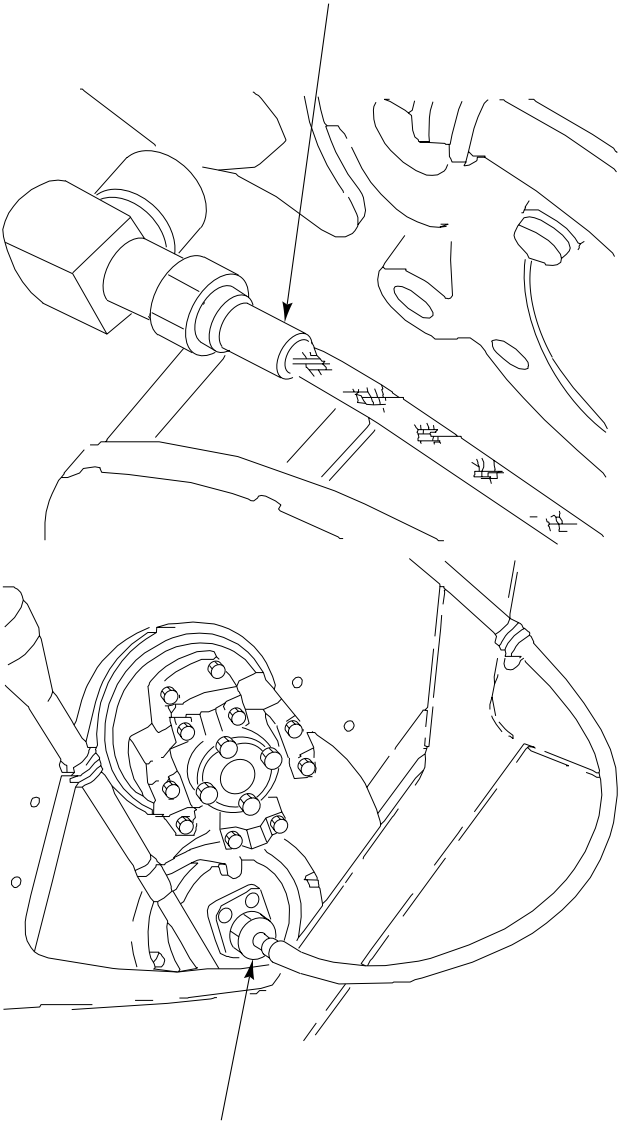
ITEM NO.	INTERVAL	MAN-HOUR	ITEM TO BE CHECKED OR SERVICED	CREWMEMBER PROCEDURE	EQUIPMENT NOT READY/AVAILABLE IF:
<p>TACHOMETER SHAFT</p>  <p>SPEEDOMETER SHAFT</p>					

**PREVENTIVE MAINTENANCE CHECKS AND SERVICES (PMCS), INCLUDING
LUBRICATION INSTRUCTIONS — Continued**

0155 00

The following list of parts are required when performing semi-annual, annual, or on-condition PMCS. The semiannual parts list contain the mandatory replacement parts for one semi-annual PMCS. The annual parts list contains the mandatory replacement parts for one semi-annual PMCS combined with the mandatory replacement parts for one (1) annual PMCS. The on-condition parts list contains replacement parts that are required when engine and transmission oil changes are directed by the Army Oil Analysis Program (AOAP) Laboratory. If AOAP Laboratory support is not available, change oil and filter elements/gasket every 150 hours/1500 miles or annually.

Table 20. SEMIANNUAL (1500 MILES)

Item No.	Part Number	NSN	Nomenclature	Qty
1	MS28778-12	5330-00-251-8839	PACKING	1

Table 21. ANNUAL (1500 MILES)

Item No.	Part Number	NSN	Nomenclature	Qty
1	MS28778-12	5330-00-251-8839	PACKING	1
2	IO874832	4730-00-766-4714	FILTER	1
3	MS28775-231	5330-00-527-7025	PACKING	1
4	5574161	5330-00-846-9841	GASKET	1
5	CW226MP	2910-00-287-1912	FILTER, ELEMENT	1
6	5574126	5330-00-612-3123	GASKET	1
7	1503536	5330-00-551-0433	GASKET	1
8	T552	2940-00-745-7730	FILTER, ELEMENT	1
9	5703232	2940-01-214-9303	PARTS KIT, FLUID PRE	1

Table 22. ON-CONDITION (1500 MILES)

Item No.	Part Number	NSN	Nomenclature	Qty
1	57023089	2940-00-678-0641	PARTS KIT	1
2	FL804FP	2940-01-197-7106	FILTER ELEMENT, FLUID	1
3	5703232	2940-01-214-9303	PARTS KIT, FLUID PRE	1
4	MS28775-231	5330-00-527-7025	PACKING	1
5	10874832	4730-00-766-4714	FILTER	1
6	MS35338-45	5310-00-407-9566	WASHER , LOCK	1

CHAPTER 4
UNIT MAINTENANCE INSTRUCTIONS
FOR ENGINE

WORK PACKAGE INDEX

<u>Title</u>	<u>Sequence No.</u>
REMOVE/INSTALL POWER PLANT ASSEMBLY.....	0156 00
BLOCK POWER PLANT.....	0157 00
REPLACE ENGINE MOUNTS	0158 00
REPLACE LEFT AND RIGHT AIR BOX DRAIN CHECK VALVE AND TUBES.....	0159 00
DELETED.....	0160 00
REPLACE ENGINE LIFTING BRACKET.....	0161 00
REPLACE ENGINE OIL FILLER CAP.....	0162 00
REPLACE ENGINE OIL SAMPLING VALVE AND HOSE.....	0163 00
REPLACE OIL GAUGE ROD AND TUBE.....	0164 00
REPLACE OIL FILTER ELEMENT.....	0165 00

REMOVE/INSTALL POWER PLANT ASSEMBLY

0156 00

THIS WORK PACKAGE COVERS:

Removal (page 0156 00-1).
 Installation (page 0156 00-13).

INITIAL SETUP:

Maintenance Level

Unit

References

See your -10

Tools and Special Tools

General Mechanic's Tool Kit (WP 0926 00, Item 65)
 Power Plant Sling (WP 0926 00, Item 48)
 Torque Wrench (WP 0926 00, Item 85)

Equipment Condition

Engine stopped (see your -10)
 Carrier blocked (see your -10)
 Driver's power plant access panel removed (see your -10)
 Power plant rear access panel removed (see your -10)
 Propeller shafts and U-joints removed (WP 0405 00)
 Cooling system drained (WP 0227 00)
 Battery ground strap disconnected (WP 0337 00) or (WP 0338 00)
 Power plant grill raised (WP 0464 00)
 Power plant sling preoperative check performed (WP 0673 00)

Materials/Parts

Cotter pin (5)
 Locknut (8)
 Lockwasher (2)
 Propeller shaft screw (4)
 Spring tension washer
 Strap

Personnel Required

Unit Mechanic
 Helper (H)

REMOVAL

NOTE

Install covers on disconnected air cleaner lines and components during maintenance. Use tape, cloth, cardboard, or any appropriate material to prevent damage to components.

1. Disconnect air supply hose (1) from elbow (2) on air cleaner (3).
2. Disconnect air restriction indicator hose (4) from bulkhead adapter (5) and reducer (6).
3. Remove strap (7) from hose (4) and air intake elbow (8). Discard strap.

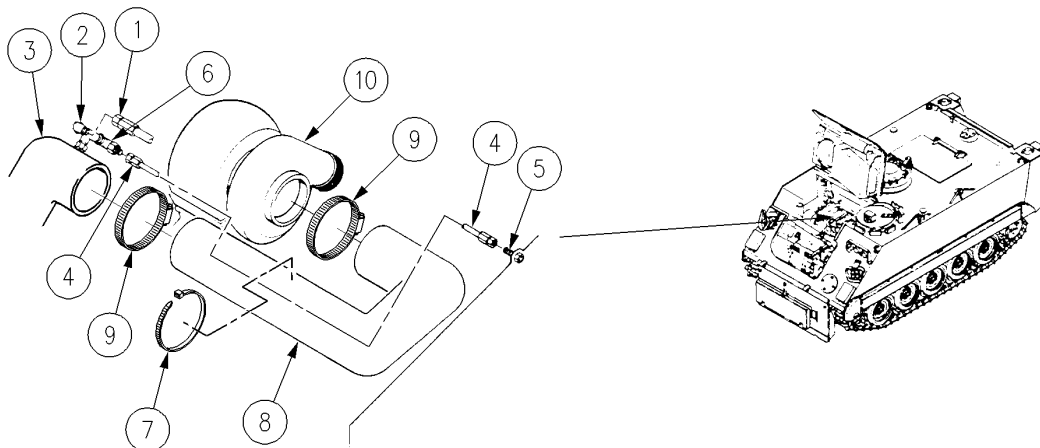

4. Loosen two clamps (9) and remove air intake elbow (8) from turbocharger inlet (10) and air cleaner (3).

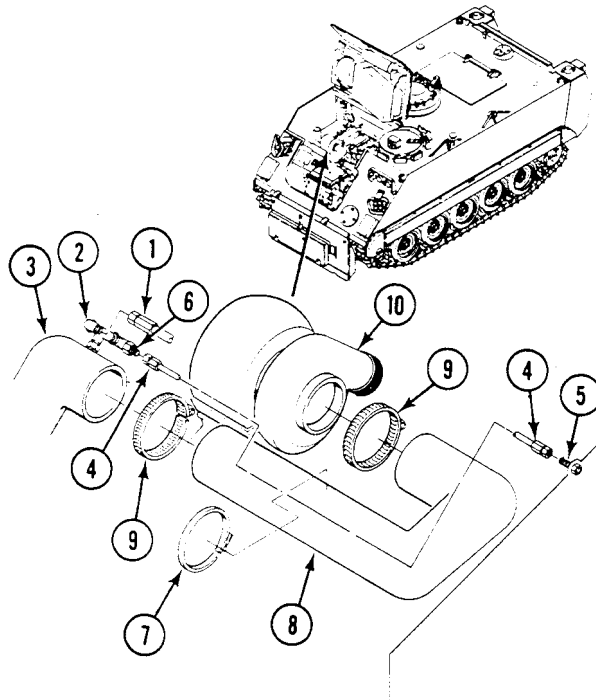

5. Disconnect return and supply fuel hoses (1) and (2) at quick disconnect (3) and (4).

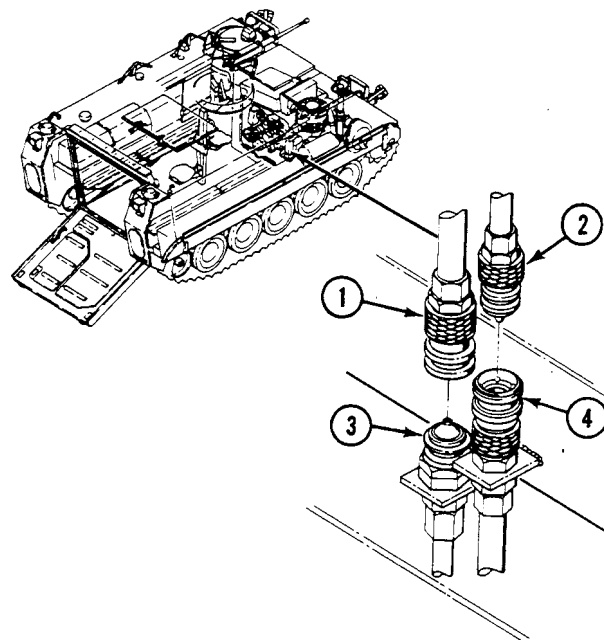

WARNING

Hydraulic fluid is poisonous and can be absorbed through your skin. Wash off any hydraulic fluid which contacts your skin. Read the hydraulic fluid warning in the front of this manual.

6. Disconnect ramp hydraulic hoses (5) and (6) at quick disconnects (7) and (8).

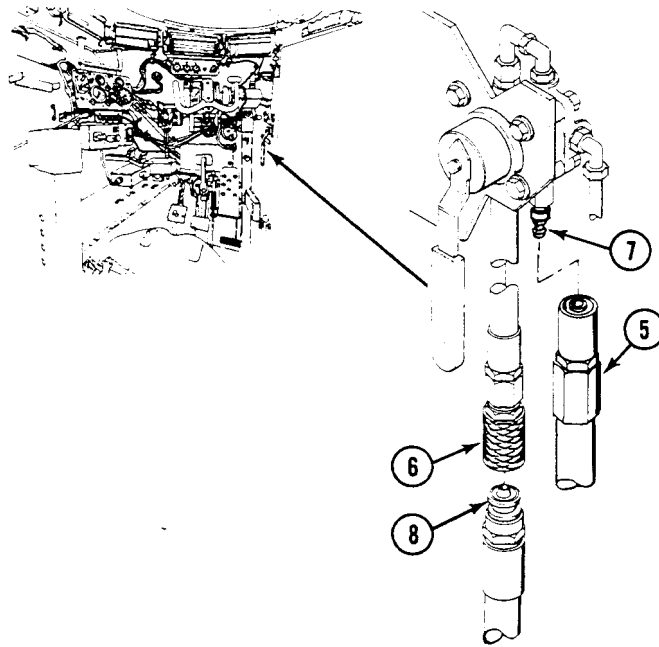

7. If engine coolant heater kit is installed, loosen clamp (9) at coolant pump shutoff valve (10) and remove hose (11).

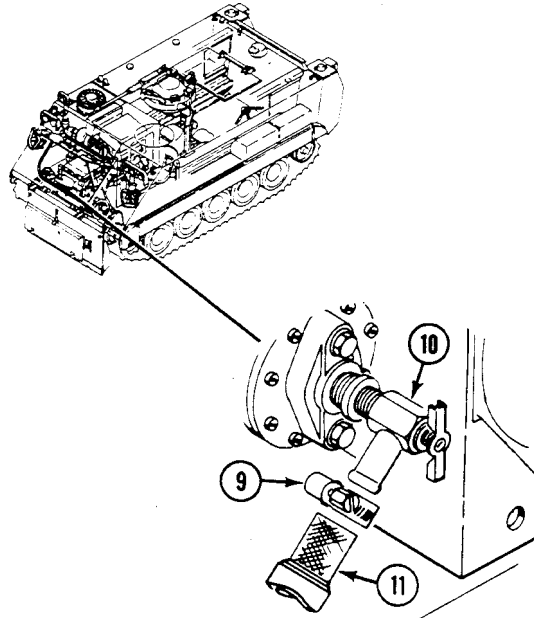

8. If engine coolant heater kit is installed, loosen clamp (12) on engine coolant elbow (13) located on bottom left side of engine manifold and remove hose (14).

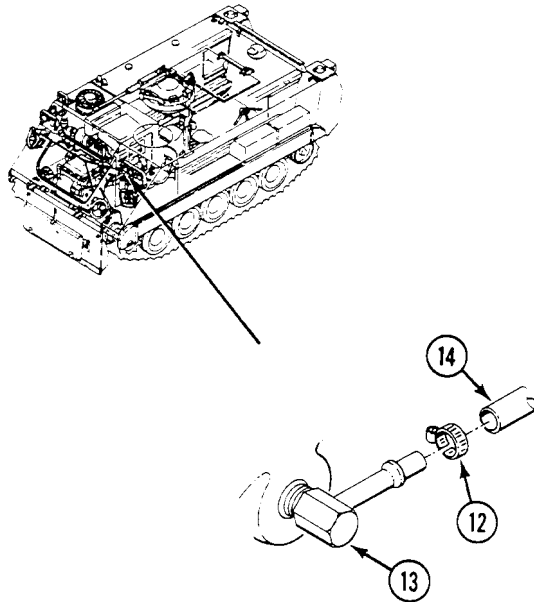

- Remove locknut (1), screw (2), two washers (3), and spring tension washer (4) from hull ground lug (5). Disconnect ground leads (6) and (7) from hull ground lug. Discard spring tension washer and locknut.

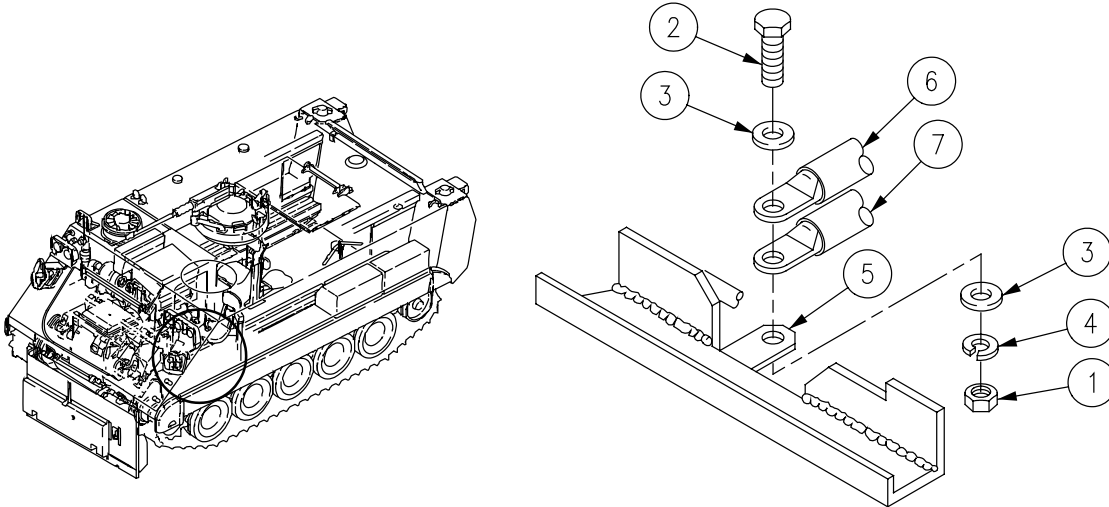

NOTE

New and Old Configuration refer to Variable Speed Fan Drive configurations.

- Disconnect five cannon plugs (8) (Old Configuration) and seven cannon plugs (8) (New Configuration) at driver's compartment bulkhead.

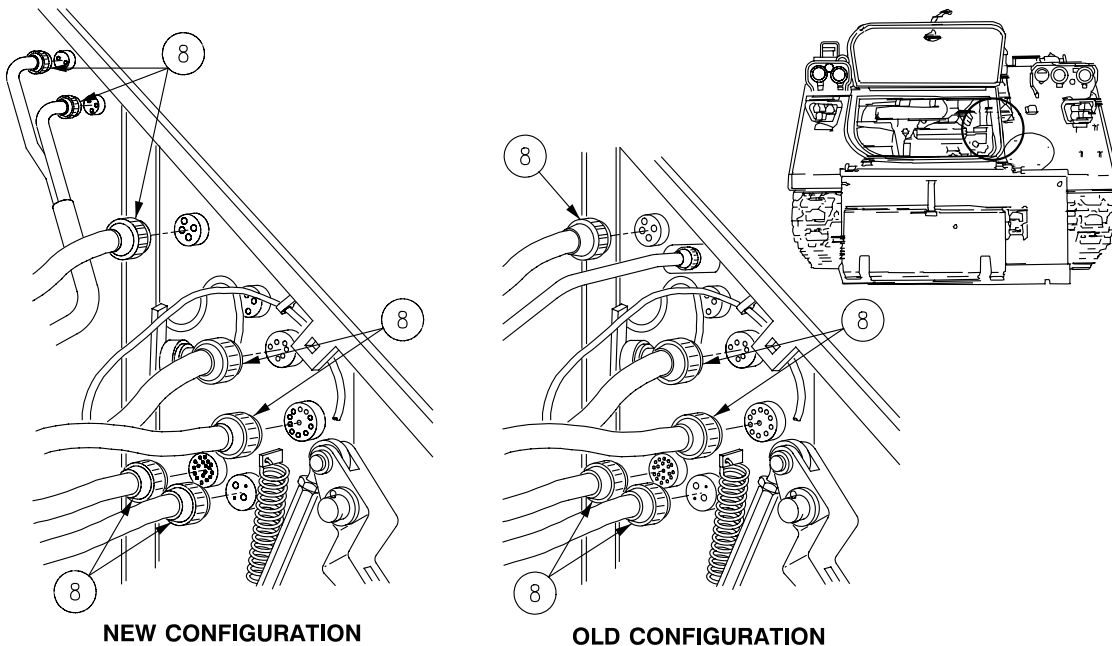

11. Remove cotter pin (9), straight pin (10), washer (11), and shutoff cable (12) from governor arm (13). Discard cotter pin.
12. Remove screw (14), washer (15), and clamp (16) with shutoff cable (12) from governor housing (17).

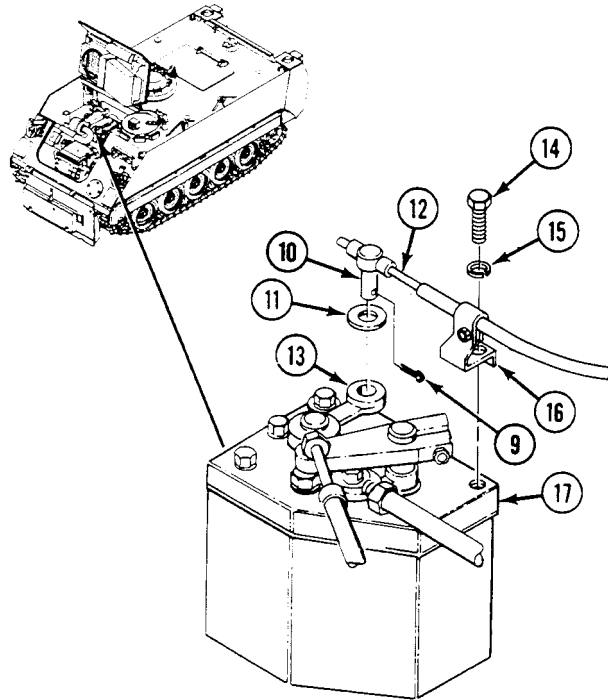

13. Remove locknut (18), washer (19), and bolt (20) from throttle link (21). Disconnect throttle link from throttle arm (22). Discard locknut.

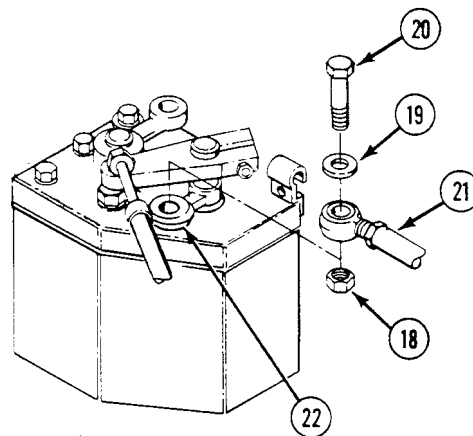

REMOVE/INSTALL POWER PLANT ASSEMBLY — Continued

0156 00

14. Remove two locknuts (10), screws (3), washers (2), two straps (5), and tow start cable (4) from bracket (1). Remove cotter pin (12), two washers (11), and pin (6) from control arm (13). Loosen set screw (9) and remove collar (8) and cable from arm. Discard cotter pin and locknut.

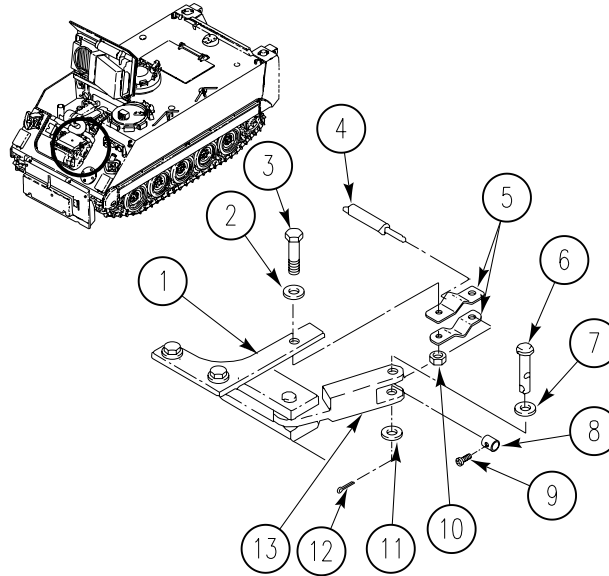

15. Remove two screws (13), washers (14), locknuts (15), and link (16) from link (17) and pivot shaft arm (18). Discard locknuts.

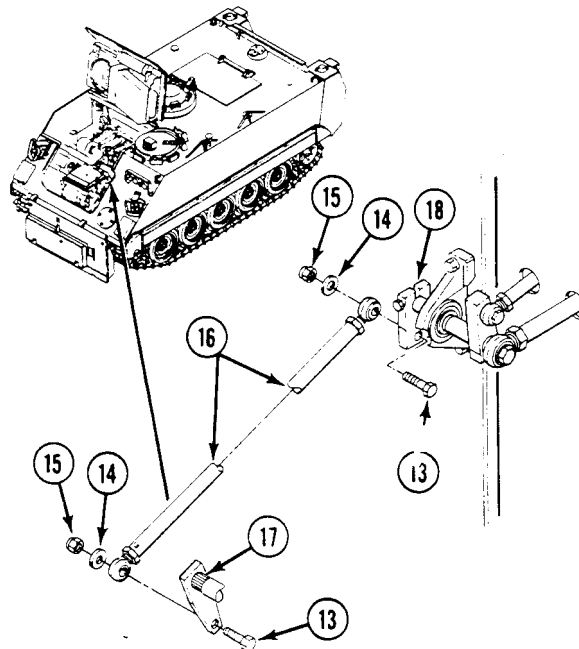

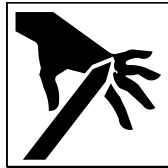
WARNING

Removing lower brake bearing from brake pivot shaft link while parking brake is on can cause shaft link to spring up and injure personnel. Disengage parking brake when doing this task.

16. Remove cotter pin (19), two washers (20), pin (21), and lower brake bearing (22) from brake pivot shaft link (23). Discard cotter pin.
17. Remove two screws (24), washers (25), lockwashers (26), and brake arms (27) and (28) from transmission. Discard lockwashers.
18. Remove cotter pin (29), two washers (30), pin (31), and link (32) from link (23). Discard cotter pin.
19. Remove cotter pin (33), washer (34), link (23) and assembly from shaft (35). Discard cotter pin.

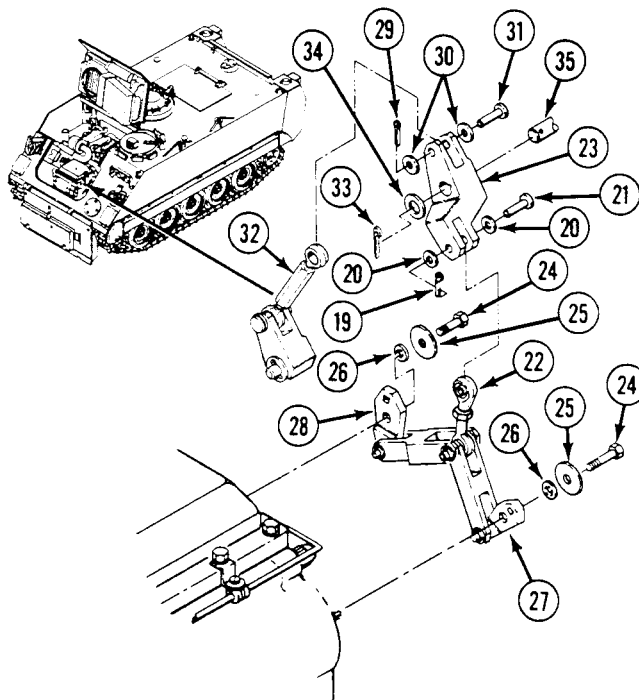

20. Remove two clamps (1) from elbow (2) and remove elbow from exhaust manifold (3) and turbo inlet (4).

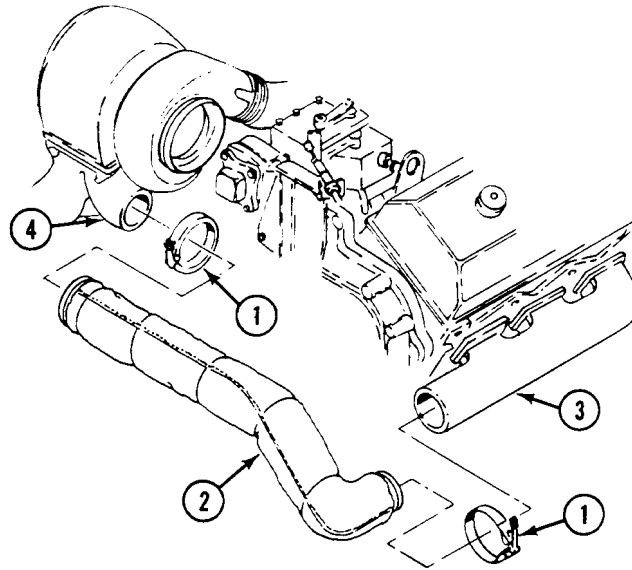

21. Disconnect tachometer cable (5) from adapter (6).

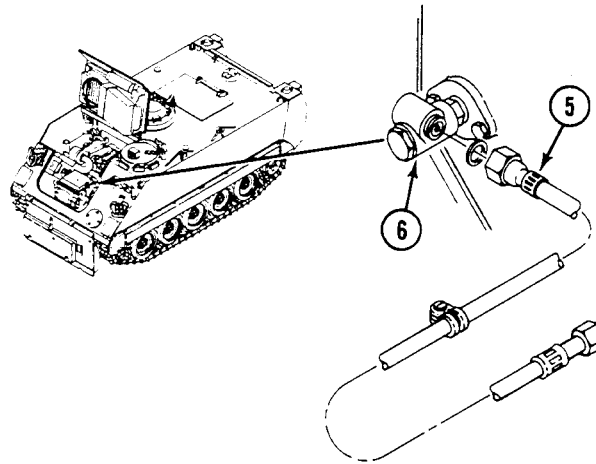

22. Remove air cleaner cover (7).

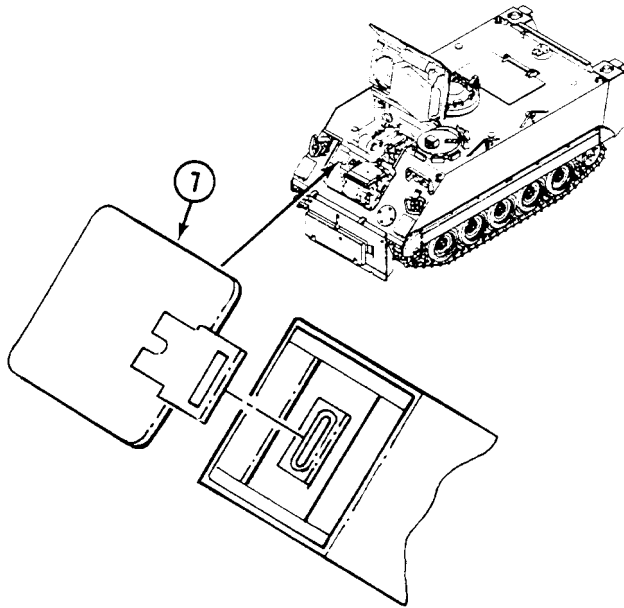

23. Remove four screws (8) and washers (9) from caps (10) and transmission mounts (11). Remove caps.

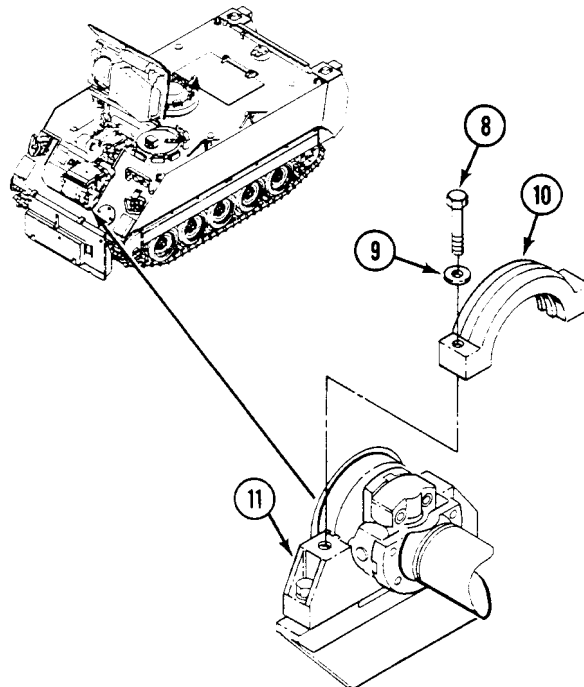

24. Disconnect engine coupling clamps (1) from rear power plant mount (2).

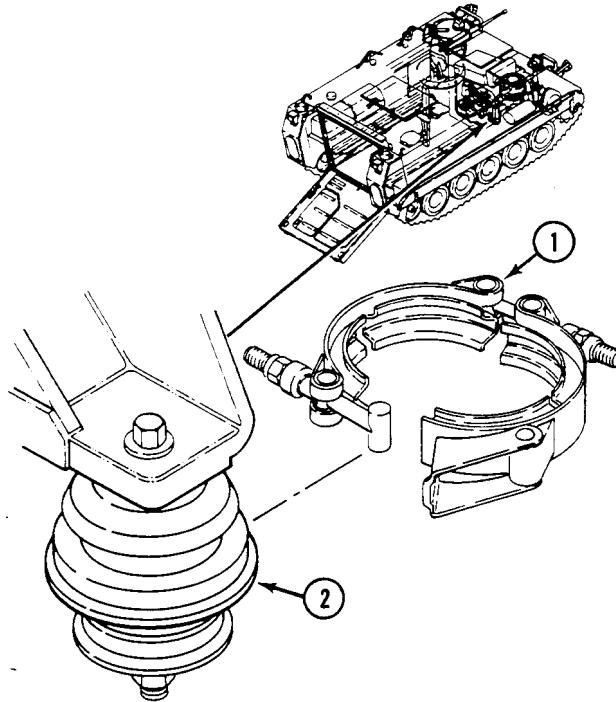

WARNING

Damaged lifting slings can fail with load. Soldiers can be killed or injured. Inspect all slings (WP 0673 00) before use. Do not use damaged slings.

WARNING

Hanging loads can kill or injure you. Keep away from hanging loads and overhead equipment. Keep hands out of compartment while power plant is being lifted for removal or lowered for installation.

25. Attach power plant sling (3) to lifting brackets (4) and lift power plant assembly. Have helper assist.

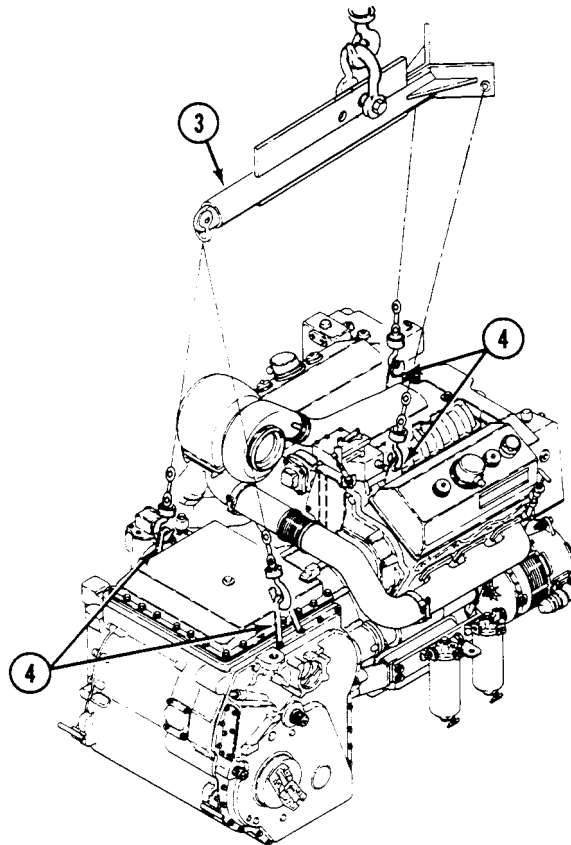

NOTE

Make sure spacer plate (half ring) stays in right side of transmission mount when power plant assembly is removed.

26. Remove power plant assembly from carrier and place on blocks (WP 0157 00). Have helper assist.

INSTALLATION**WARNING**

Damaged lifting slings can fail with load. Soldiers can be killed or injured. Inspect all slings (WP 0673 00) before use. Do not use damaged slings.

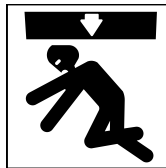
WARNING

Hanging loads can kill or injure you. Keep away from hanging loads and overhead equipment. Keep hands out of compartment while power plant is being lifted for removal or lowered for installation.

1. Attach power plant lifting sling (3) to power plant. Have helper assist.

NOTE

If engine mounts have been replaced, make sure mounts are aligned with hull mounts and nuts are torqued (WP 0158 00) before detaching sling.

Make sure spacer plate (half ring) is in the right side transmission mount slot before lowering power plant.

2. Lower power plant into carrier. Detach sling. Have helper assist.

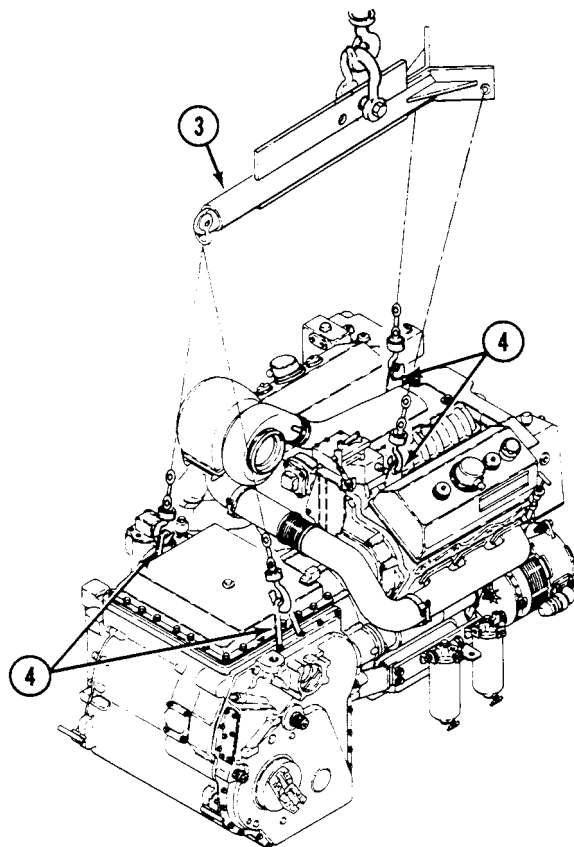

3. Install engine coupling clamps (1) on power plant mounts (2).

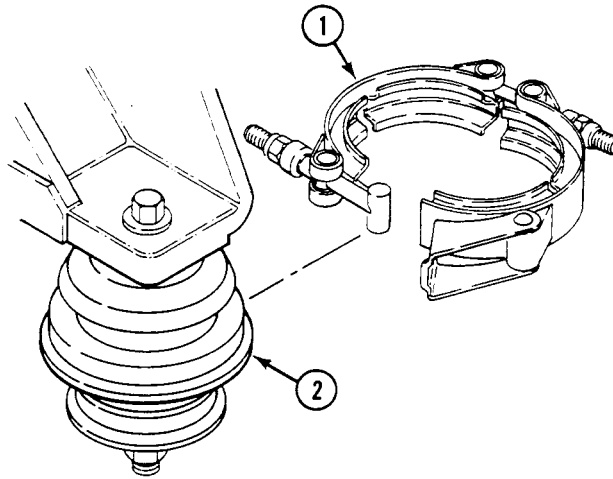

4. Install caps (3) on transmission mounts (4). Secure with four screws (5) and washers (6). Tighten screws to 86-94 lb-ft (107-126 N·m) torque.

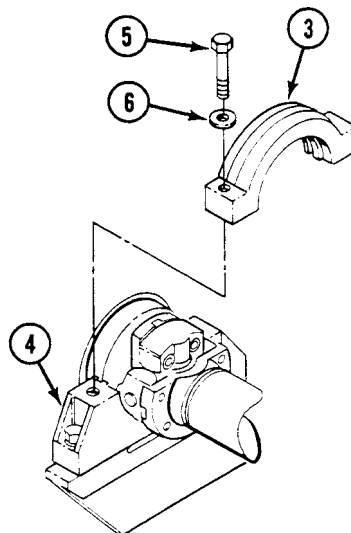

5. Install air cleaner cover (7).

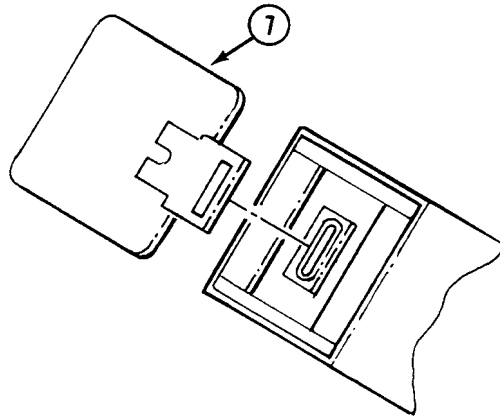

6. Install tachometer cable (8) on tachometer adapter (9).

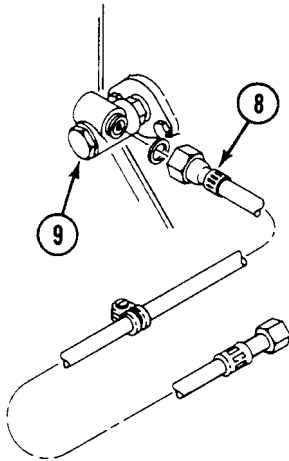

7. Install elbow (1) on turbo inlet (2) and exhaust manifold (3). Secure with two clamps (4).

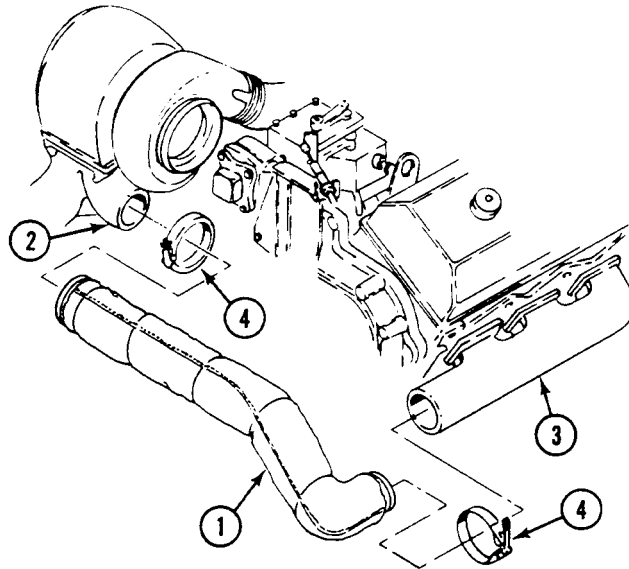

8. Install pivot shaft link (5) on pivot shaft (6). Secure with flat washer (7) and new cotter pin (8).
9. Install brake arms (9) and (10), links (11), and bearing (12) on transmission. Secure with two flat washers (13), new lockwashers (14), and screws (15).
10. Install lower bearing (12) on shaft link (5). Secure with pin (16), two washers (17), and new cotter pin (18).
11. Install link (19) on link (5). Secure with pin (20), two washers (21), and new cotter pin (22).

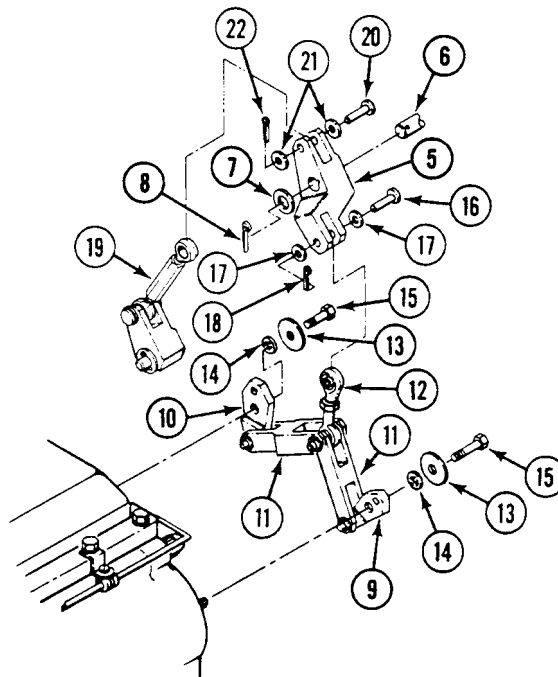

12. Install link (23) on link (24) and pivot shaft arm (25). Secure with two screws (26), washers (27), and new locknuts (28).

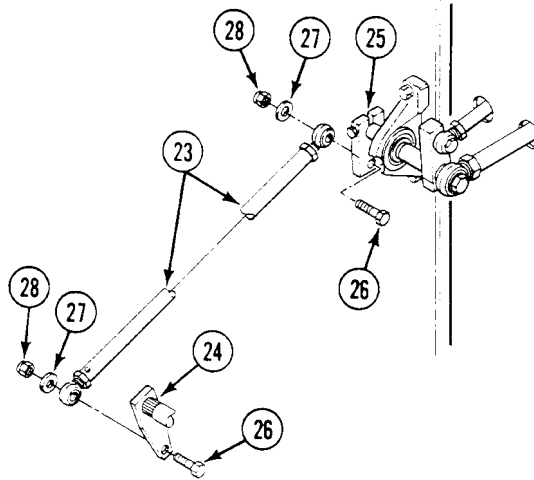

13. Install tow start cable (4) and two straps (5) on bracket (1). Secure with two locknuts (10), screws (3), and washers (2). Install control arm pin (6) and washer (7) in bracket (13). Install tow start cable in pin. Secure with collar (8). Secure pin to bracket with washer (11) and new cotter pin (12). Tighten set screw (9).

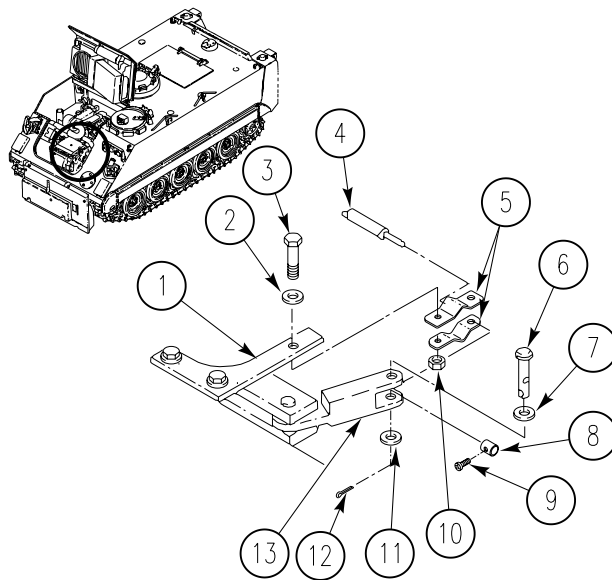

14. Install throttle link (14) on throttle arm (15). Secure with bolt (16), washer (17), and new locknut (18).

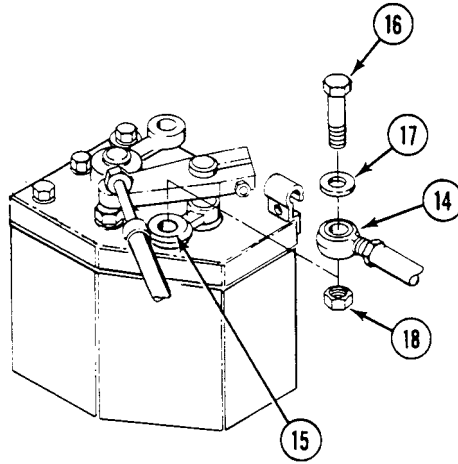

15. Install straight pin (19) with shutoff cable (20) on governor arm (21). Secure with washer (22) and new cotter pin (23).

16. Install clamp (24) with shutoff cable (20) on governor housing (25). Secure with washer (26) and screw (27).

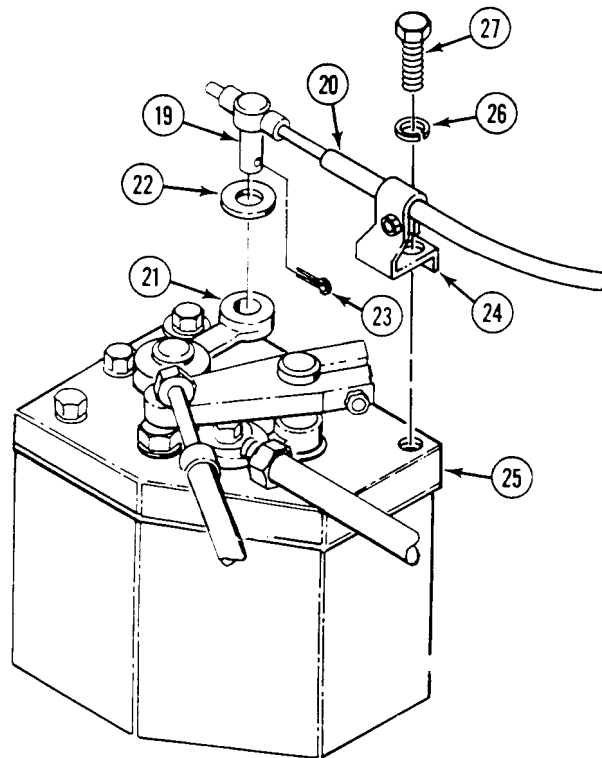

17. Install five cannon plugs (1) (Old Configuration) and seven cannon plugs (1) (New Configuration) on driver's compartment bulkhead.

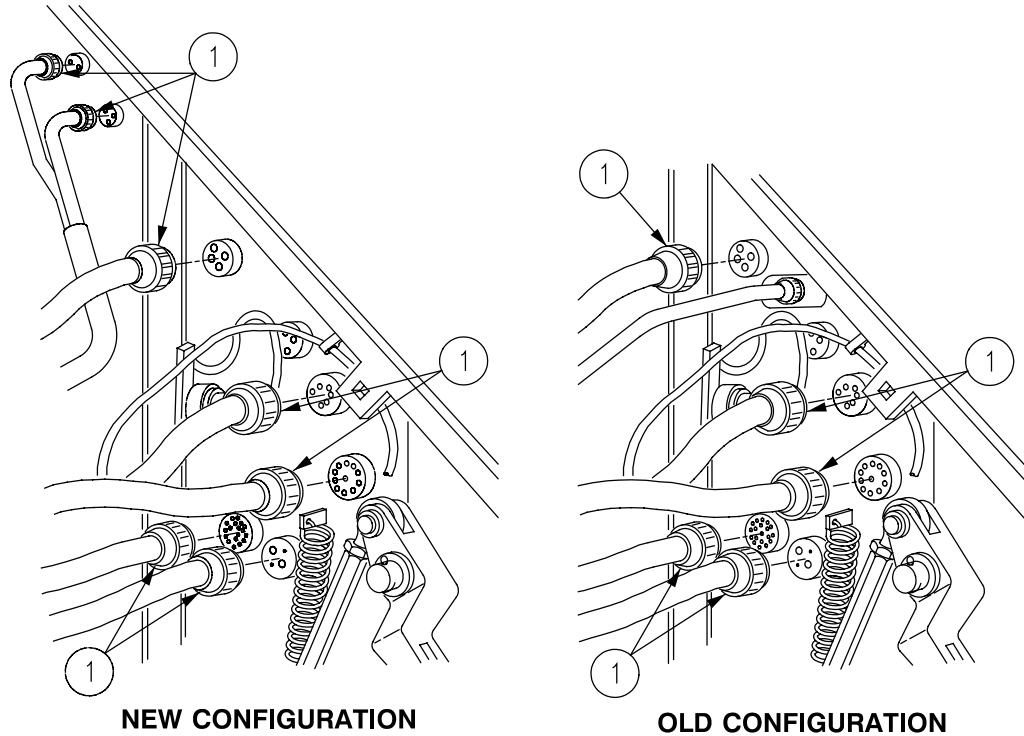

18. Install two ground leads (2) and (3) on hull ground lug (4). Secure with bolt (5), two flat washers (6), new spring washer (7), and new locknut (8).

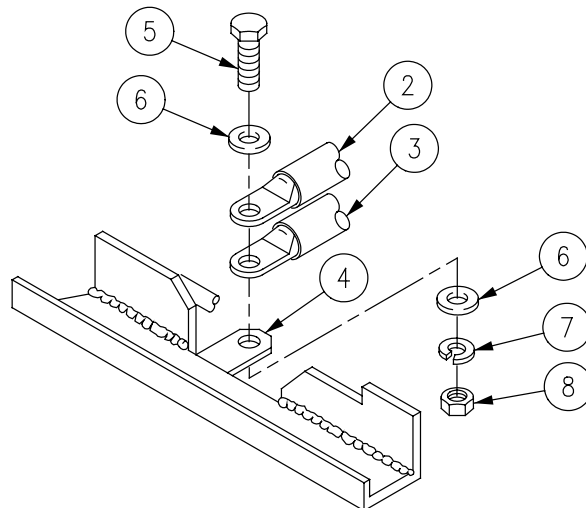

19. If engine coolant heater kit is installed, install hose (9) on coolant pump shutoff valve (10). Secure with clamp (11).

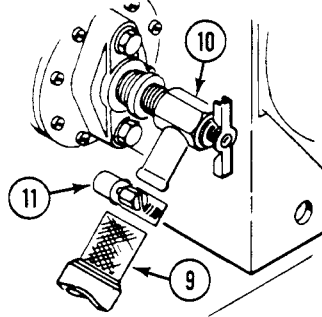

20. If engine coolant heater kit is installed, install hose (12) on engine coolant elbow (13) located on bottom left side of engine manifold. Secure with clamp (14).

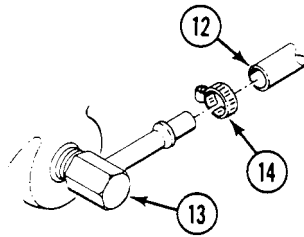

WARNING

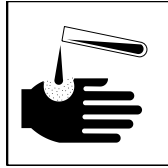

Hydraulic fluid is poisonous and can be absorbed through your skin. Wash off any hydraulic fluid which contacts your skin. Read the hydraulic fluid warning in the front of this manual.

21. Install two ramp hydraulic hoses (1) and (2) on quick disconnects (3) and (4).

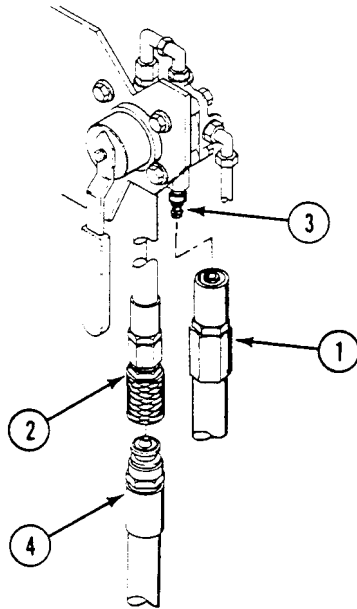

22. Install two fuel supply and return hoses (5) and (6) on quick disconnects (7) and (8).

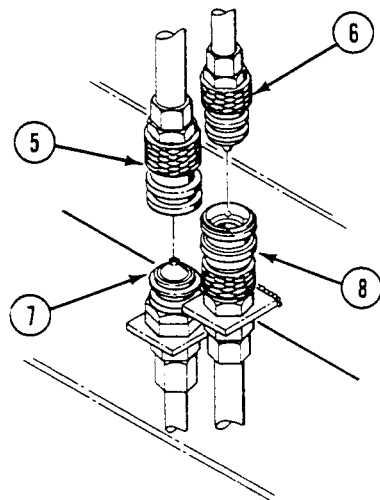

23. Install air intake elbow (9) on turbocharger inlet (10) and air cleaner (11). Secure with two clamps (12).
24. Install air restriction indicator hose (13) on bulkhead adapter (14) and reducer (15).
25. Install new strap (16) on hose (13) and air intake elbow (9).
26. Install air supply hose (17) on elbow (18) on air cleaner (11).

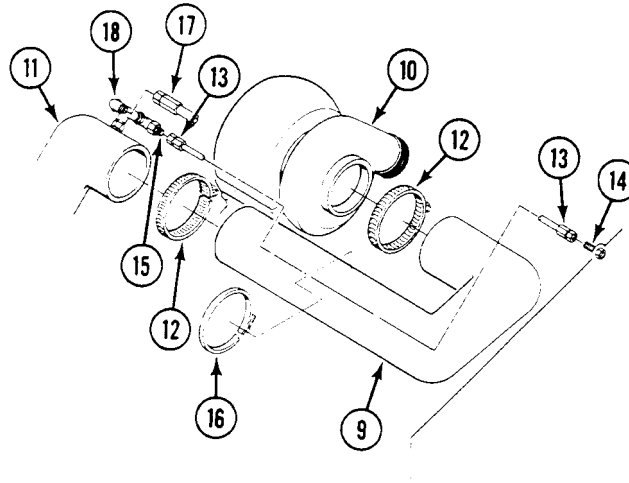

FOLLOW-THROUGH STEPS

1. Lower power plant grill (WP 0464 00).
2. Fill cooling system (WP 0227 00).
3. Connect battery ground strap (WP 0337 00) or (WP 0338 00).
4. Install propeller shafts and U-joints (WP 0405 00).
5. Perform brake adjustment check (WP 0406 00).
6. Start engine (see your -10). Check for leaks.
7. Stop engine. Turn MASTER SWITCH OFF (see your -10).
8. Install power plant rear access panel (see your -10).
9. Install driver's power plant access panel (see your -10).

END OF TASK

BLOCK POWER PLANT

0157 00

THIS WORK PACKAGE COVERS:

Jacking (page 0157 00-1).

INITIAL SETUP:

Maintenance Level

Unit

Personnel Required

Unit Mechanic
Helper (H)

Tools and Special Tools

General Mechanic's Tool Kit (WP 0926 00, Item 65)
Power Plant Sling (WP 0926 00, Item 48)

References

See your -10

Materials/Parts

Lumber, 4 x 6 x 40 inch (10 x 15 x 102 cm)
Lumber, 4 x 6 x 20 inch (10 x 15 x 51 cm) (2)

Equipment Condition

Engine stopped (see your -10)
Carrier blocked (see your -10)
Power plant removed (WP 0156 00)

PARKING

BLOCK POWER PLANT

WARNING

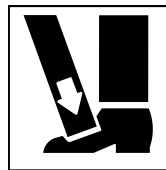

Blocking power plant on unlevel, soft ground can cause power plant to sink and tip over. Personnel can be injured and power plant can be damaged. Make sure to block power plant on flat, hard ground.

1. Use a lifting device of at least 3,000 pounds (1,362 kg) capacity and sling to lift power plant.
2. On level ground, place a 4 x 6 x 40 inch (10 x 15 x 102 cm) block (1) under motor mounts of the engine (2).
3. On level ground, place two 4 x 6 x 20 inch (10 x 15 x 52 cm) blocks (3) and (4) under transmission (5).
4. Lower power plant down slowly onto blocks. Have helper assist.

5. Check that power plant is firmly supported by the blocks.

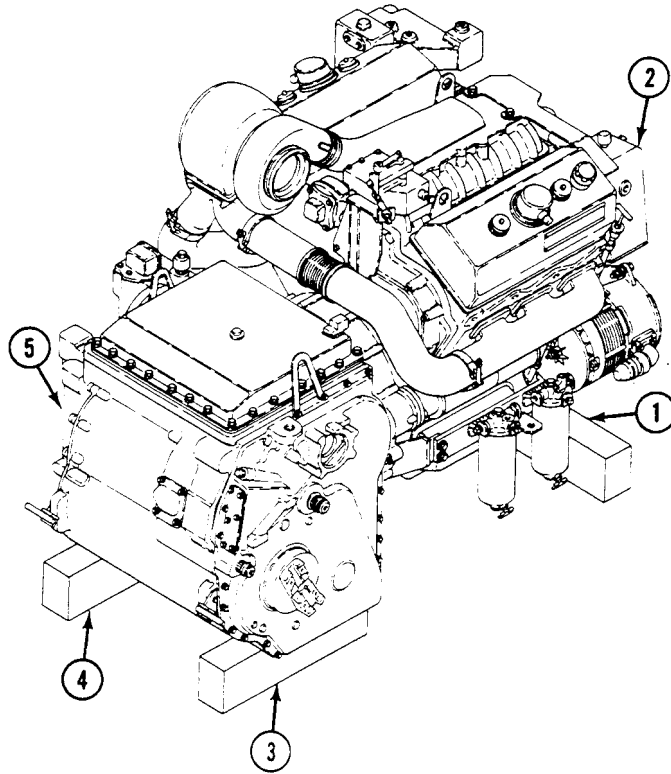

END OF TASK

REPLACE ENGINE MOUNTS

0158 00

THIS WORK PACKAGE COVERS:

Removal (page 0158 00-1).
 Installation (page 0158 00-2).

INITIAL SETUP:

Maintenance Level

Unit

References

See your -10

Tools and Special Tools

General mechanic's tool kit (WP 0926 00, Item 65)
 Torque wrench (WP 0926 00, Item 85)

Equipment Condition

Engine stopped (see your -10)
 Carrier blocked (see your -10)
 Battery ground strap disconnected (WP 0337 00) ,
 (WP 0338 00) , or (WP 0339 00) .
 Power plant removed (WP 0156 00)

Materials/Parts

Locknut

Personnel Required

Unit Mechanic

REMOVAL

NOTE

Right and left engine mounts are replaced in the same way.

1. Remove screw (1) , two washers (2) , two washers (3) , two mounts (4) , block (5) , and locknut (6) from engine. Discard locknut.

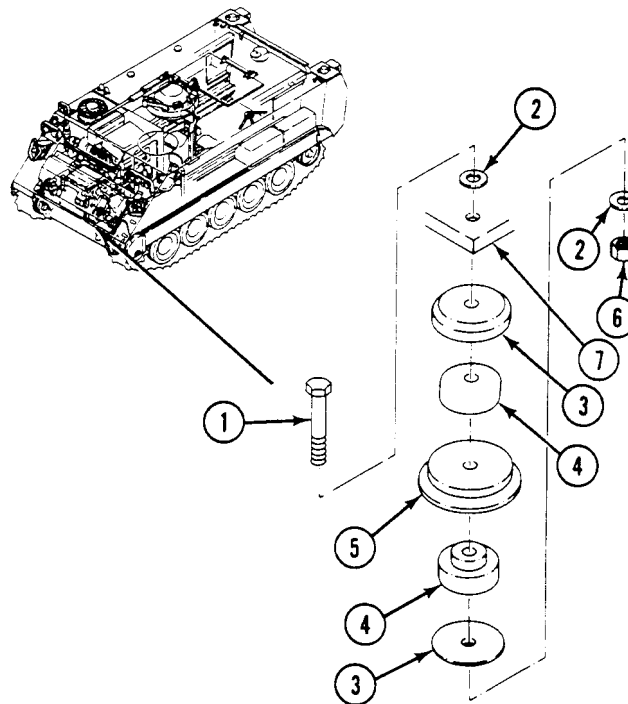

INSTALLATION

1. Install screw (1) and washer (2) in engine mount base (7).

NOTE

Do not torque nuts until engine mounts are properly aligned on hull mounts.

2. Lightly lubricate two mounts (4) with water. Install washer (3), mount (4), block (5), mount (4), and two washers (2) and washer (3) on engine. Secure with new locknut (6). Tighten nut to 100-120 lb-ft (136-163 N·m) torque.

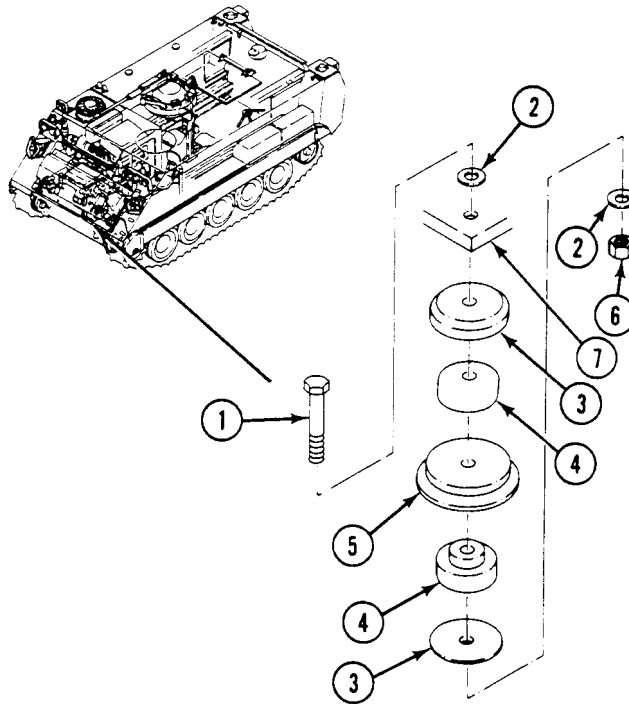
**FOLLOW-THROUGH STEPS**

1. Install power plant (WP 0156 00).
2. Connect battery ground strap (WP 0337 00), (WP 0338 00), or (WP 0339 00).

END OF TASK

REPLACE LEFT AND RIGHT AIR BOX DRAIN CHECK VALVES AND TUBES

0159 00

THIS WORK PACKAGE COVERS:

- Removal (page 0159 00-1).
- Installation (page 0159 00-13).

INITIAL SETUP:

Maintenance Level

Unit

Personnel Required

Unit Mechanic

Tools and Special Tools

- General Mechanic's Tool Kit (WP 0926 00, Item 65)
- Torque Wrench (WP 0926 00, Item 85)

References

See your -10

Materials/Parts

- Sealing compound (WP 0928 00, Item 56)
- Locknuts (2)
- Lockwashers (3)
- Washers, copper (2)

Equipment Condition

- Engine stopped (see your -10)
- Carrier blocked (see your -10)
- Driver's power plant access panel removed (see your -10 (right side only))
- Starter removed (WP 0259 00 (right side only))
- Power plant removed (WP 0156 00 (left side only))

REMOVAL

1. Remove two screws (1), four washers (2), two locknuts (3), and bracket (4) from engine. Discard locknuts.

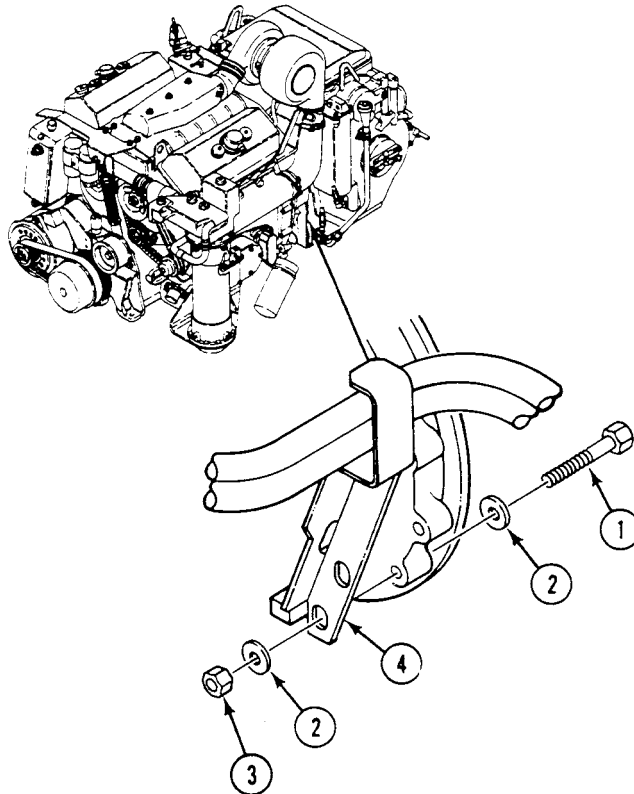

REPLACE LEFT AND RIGHT AIR BOX DRAIN CHECK VALVES AND TUBES — Continued

0159 00

2. Remove upper hose assembly (5) from elbow (6) in check valve (7) and elbow (8) on rear left cylinder block.
3. Remove lower hose assembly (9) from check valve (7) and elbow (10) on rear left oil pan.
4. If oil cooler has not been removed, remove screw (11), lockwasher (12), and flat washer (13) from clip (14) on oil cooler (15). Discard lockwasher.
5. Remove elbow (6) from check valve (7), elbow (8) from left side of cylinder block, and elbow (10) from left side of oil pan. If necessary, remove clip (14) from check valve.

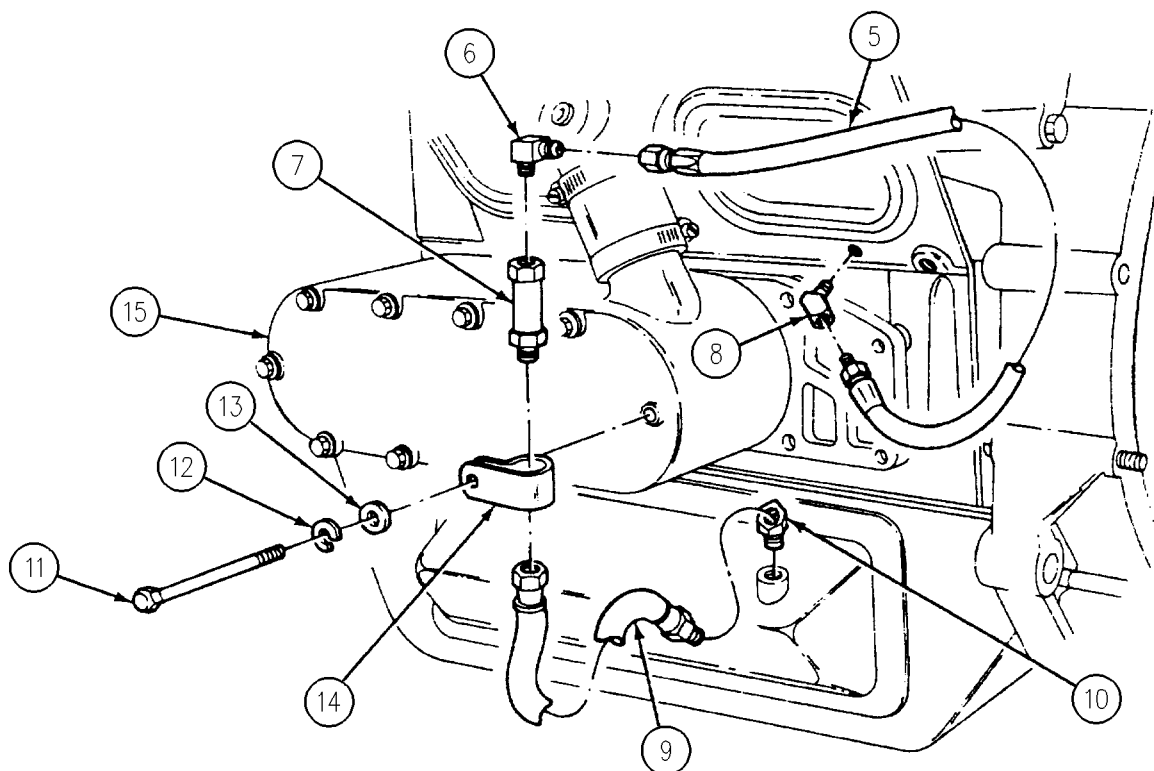

REPLACE LEFT AND RIGHT AIR BOX DRAIN CHECK VALVES AND TUBES — Continued

0159 00

6. Remove bolt (16) and lockwasher (17) from clip (18) on upper tube assembly (19). Discard lockwasher.
7. Remove upper tube assembly (19) from elbow (20) in check valve (21) and elbow (22) in rear right cylinder block. If necessary, remove clip (18) from tube assembly.
8. Disconnect lower tube assembly (23) from check valve (21). Remove check valve.
9. Remove elbow (20) from check valve (21) and elbow (22) from cylinder block.

NOTE**For model 5063-6392, do Step 10.**

10. Remove bolt (24), lockwasher (25), and spacer (26) from clip (27) on lower tube assembly (23). Discard lockwasher.
11. Remove adapter (28), two copper washers (29), and lower tube assembly (23) from cylinder block. If necessary, remove clip (27) from tube assembly. Discard flat washers.

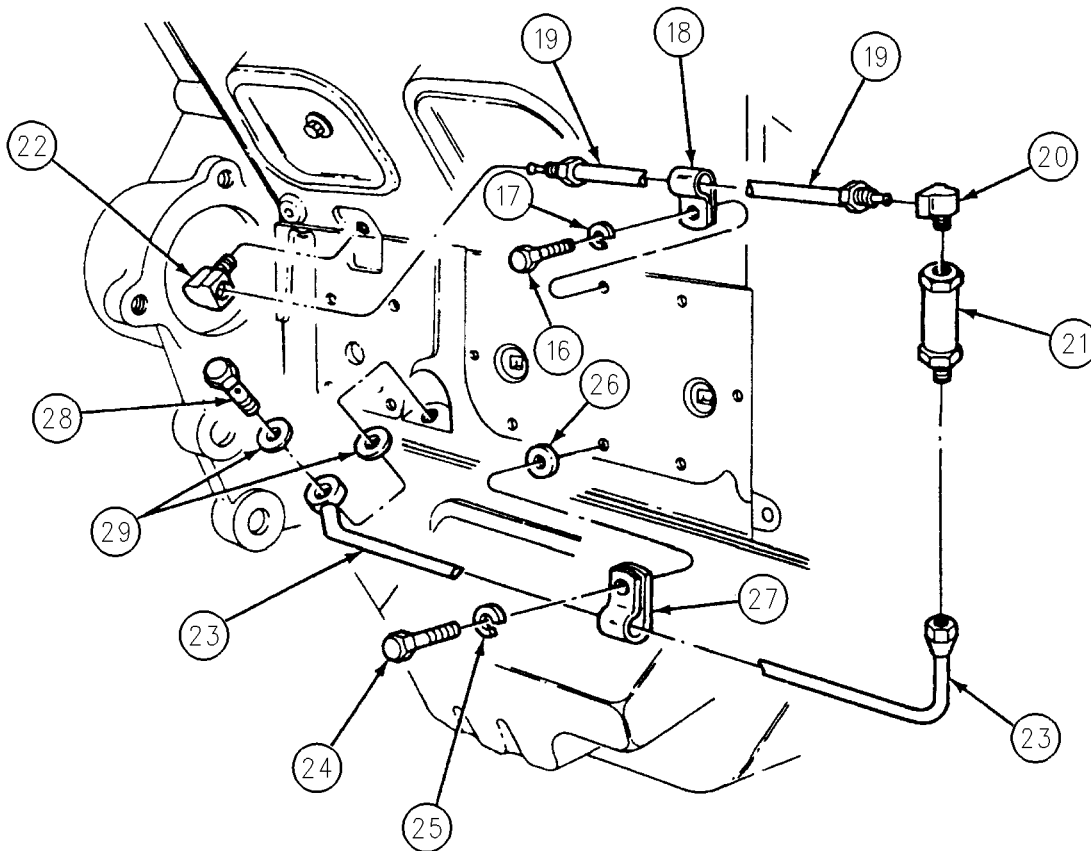

INSTALLATION

1. Loosely install lower tube assembly (23), adapter (28), and two copper washers (29) on right side of cylinder block.
2. Coat threads on elbow (22) with a pipe sealing compound and install elbow into cylinder block with port facing toward front of engine.
3. Install elbow (20) in top of check valve (21) and tighten securely.
4. Loosely connect lower tube assembly (23) to bottom of check valve (21). If removed, install clip (27) on lower tube assembly.
5. Loosely install upper tube assembly (19) in elbow (22) and elbow (20) in check valve (21). If removed, install clip (18) on upper tube assembly.
6. Install lockwasher (17) and bolt (16) through clip (18) into cylinder block.

NOTE

For model 5063-6392, do Step 7.

7. Install spacer (26), lockwasher (25), and bolt (24) through clip (27) into cylinder block.
8. Securely tighten tube assembly (19) and tube assembly (23). Torque adapter (28) to 14-16 lb-ft (19-22 N•m). Torque bolt (16) and bolt (24) to 13-17 lb-ft (18-23 N•m).

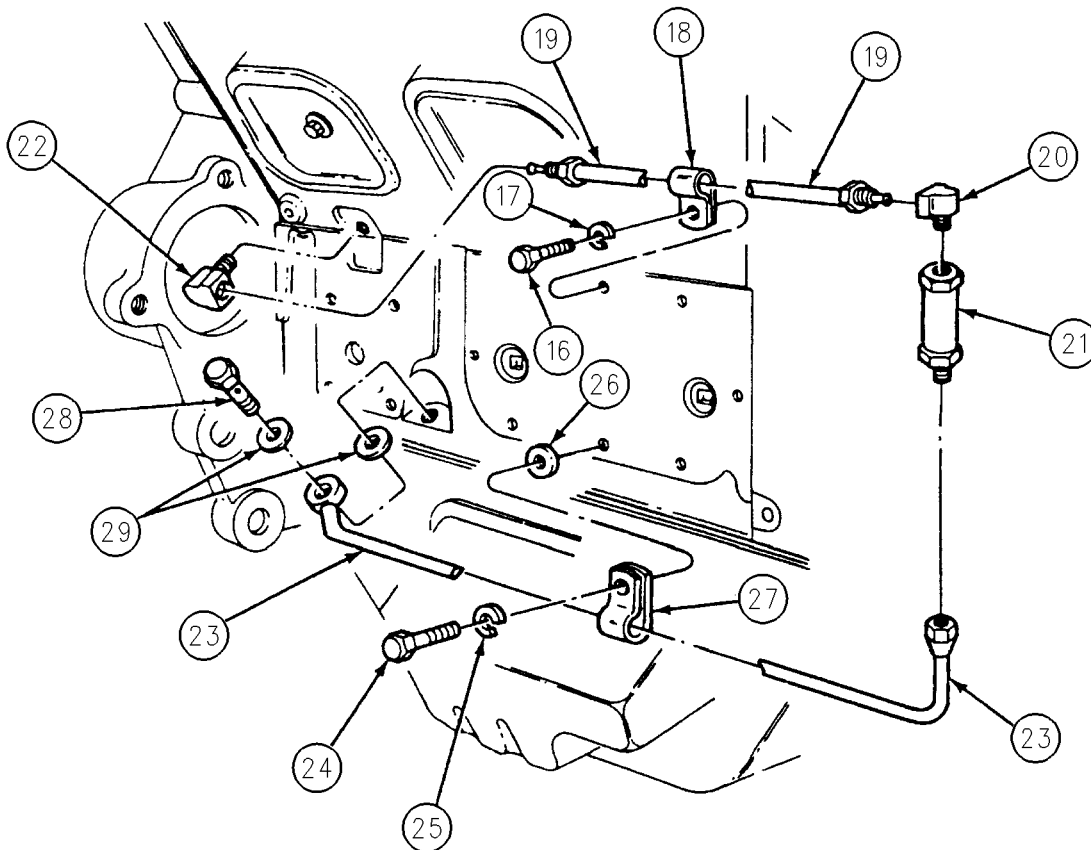

REPLACE LEFT AND RIGHT AIR BOX DRAIN CHECK VALVES AND TUBES — Continued**0159 00**

9. Coat threads on elbow (8) with a pipe sealing compound and install in left side of cylinder block. Tighten securely with port facing rear and downward at a 45 degree angle.
10. Install elbow (10) in oil pan and tighten securely with port facing outward from engine.
11. Install elbow (6) in top of check valve (7) and tighten securely. If removed, install clip (14) on check valve.
12. Connect upper hose assembly (5) to elbow (8) in cylinder block. Tighten securely.
13. Connect lower hose assembly (9) to elbow (10) in oil pan. Tighten securely.
14. If oil cooler is installed, install screw (11) through clip (14), new lockwasher (12), and flat washer (13) in oil cooler. Torque screw to 13-17 lb-ft (18-23 N•m).
15. Connect hose assembly (5) to elbow (6) in check valve (7) and hose assembly (9) to bottom of check valve. Tighten securely.

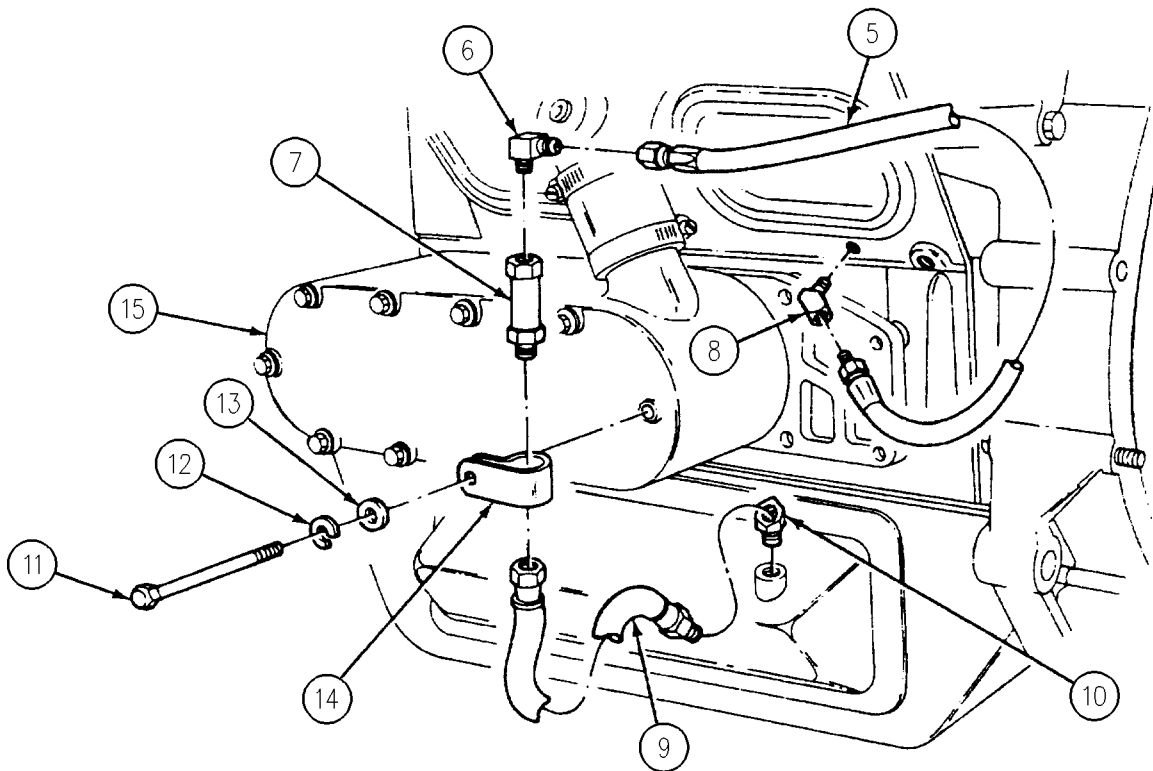

16. Install bracket (4) on engine. Secure with two screws (1), four washers (2), and two new locknuts (3).

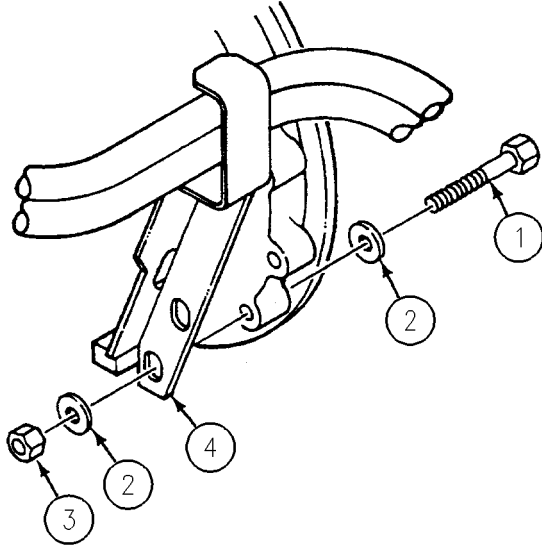

INSTALLATION

1. Install power pack (WP 0156 00 (left side only)).
2. Install driver's power plant access panel (see your -10 (right side only)).
3. Install starter (WP 0259 00 (right side only)).

END OF TASK

REPLACE RIGHT AIR BOX DRAIN CHECK VALVE AND TUBES

0160 00

THIS WORK PACKAGE COVERS:

Removal (page 0160 00-1).
 Installation (page 0160 00-2).

INITIAL SETUP:

Maintenance Level

Unit

References

See your -10

Tools and Special Tools

General Mechanic's Tool Kit (WP 0926 00, Item 65)

Equipment Condition

Engine stopped (see your -10)
 Carrier blocked (see your -10)
 Driver's power plant access panel removed (see your -10)
 Starter removed (WP 0259 00)

Materials/Parts

Adhesive (WP 0928 00, Item 4)
 Lockwasher (2)

Personnel Required

Unit Mechanic

REMOVAL

1. Loosen nut (1). Remove check valve (2) from elbow (3).
2. Remove screw (4), lockwasher (5), and washer (6) from clamp (7). Discard lockwasher.
3. Remove screw (8), two washers (9), tube (10) and clamp (7) from engine.
4. Remove elbow (3) from tube (11).
5. Remove screw (12) and lockwasher (13) from clamp (14). Discard lockwasher.
6. Remove tube (11) and clamp (14) from elbow (15).
7. Remove elbow (15) from engine.

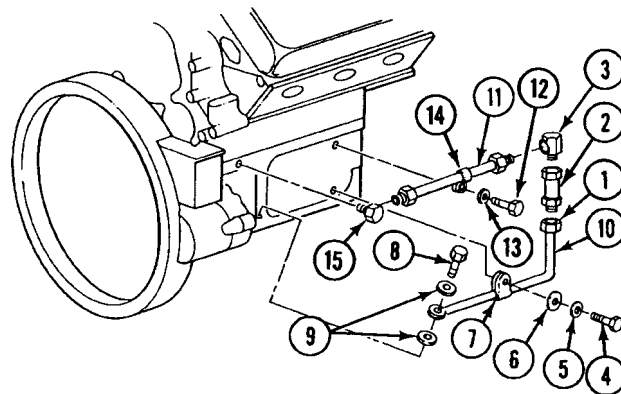

INSTALLATION

1. Apply a thin coat of adhesive to external threads of fittings.
2. Install elbow (15) on engine.
3. Install elbow (3) on tube (11). Install tube on elbow (15).
4. Install new lockwasher (13) and screw (12) on clamp (14).
5. Install tube (10), clamp (7), screw (8), and two washers (9) on engine. Do not tighten screw.
6. Install check valve (2) on elbow (3). Tighten nut (1) on check valve.
7. Install screw (4), new lockwasher (5) and washer (6) on clamp (7) and engine.
8. Tighten screw (8).

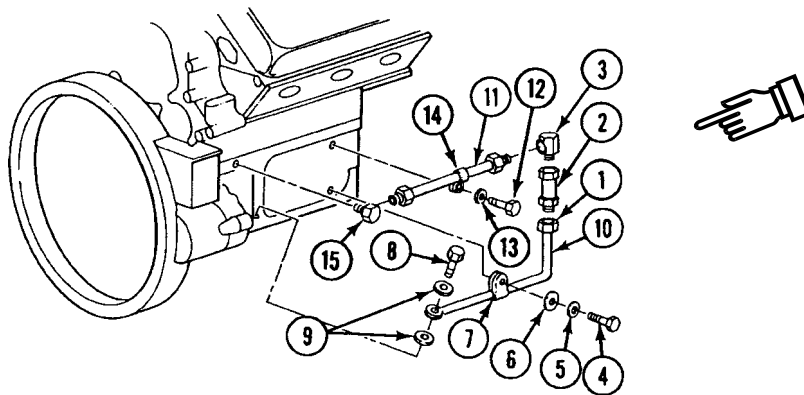
**FOLLOW-THROUGH STEPS**

1. Install starter (WP 0259 00).
2. Install driver's power plant access panel.(see your -10).

END OF TASK

REPLACE ENGINE LIFTING BRACKET

0161 00

THIS WORK PACKAGE COVERS:

Removal (page 0161 00-1).
 Installation (page 0161 00-2).

INITIAL SETUP:

Maintenance Level

Unit

References

See your -10

Tools and Special Tools

General Mechanic's Tool Kit (WP 0926 00, Item 65)

Equipment Condition

Engine stopped (see your -10)
 Carrier blocked (see your -10)
 Trim vane lowered (see your -10)
 Power plant access door open (see your -10)
 Power plant grill raised (WP 0464 00)

Materials/Parts

Lockwasher (2)

Personnel Required

Unit Mechanic

REMOVAL

NOTE

Both brackets are removed and installed the same way.

1. Remove two screws (1), lockwashers (2), and lifting bracket (3) from power plant. Discard lockwashers.

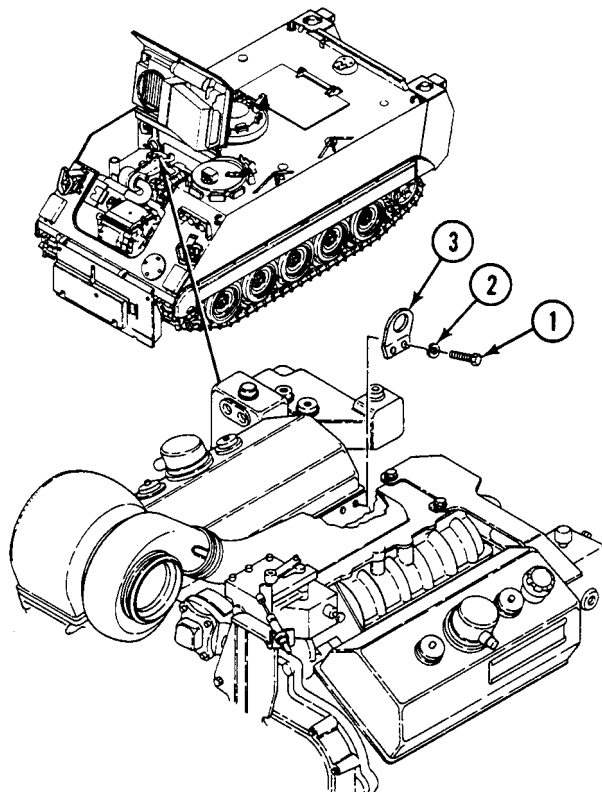

INSTALLATION

1. Install bracket (3) with two screws (1) and new lockwashers (2) on power plant.

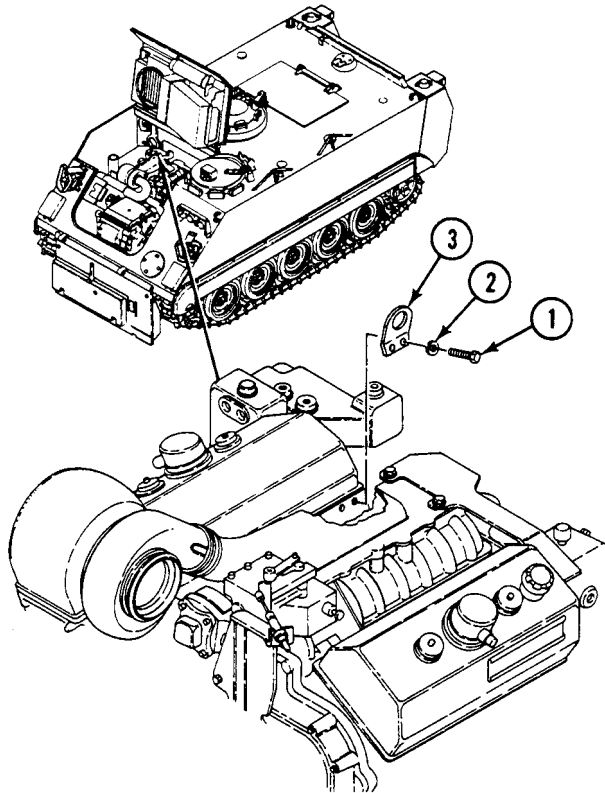
**FOLLOW-THROUGH STEPS**

1. Lower power plant grill (WP 0464 00).
2. Close power plant access door (see your -10).
3. Raise trim vane (see your -10).

END OF TASK

REPLACE ENGINE OIL FILLER CAP

0162 00

THIS WORK PACKAGE COVERS:

Removal (page 0162 00-1).
 Installation (page 0162 00-2).

INITIAL SETUP:

Maintenance Level

Unit

References

See your -10

Tools and Special Tools

General Mechanic's Tool Kit (WP 0926 00, Item 65)

Equipment Condition

Engine stopped (see your -10)

Carrier blocked (see your -10)

Materials/Parts

Filler cap

Hook (2)

Driver's power plant access panel removed
 (see your -10)

Personnel Required

Unit Mechanic

REMOVAL

1. Unscrew T-handle (1) on oil filler cap (2) and remove cap from filler hole (3).
2. Open hook (4) in filler hole (3) to remove cap (2) and chain (5). Discard hook.

3. Open hook (6) on filler cap (2) to remove hook and chain (5) from cap. Discard hook and cap.

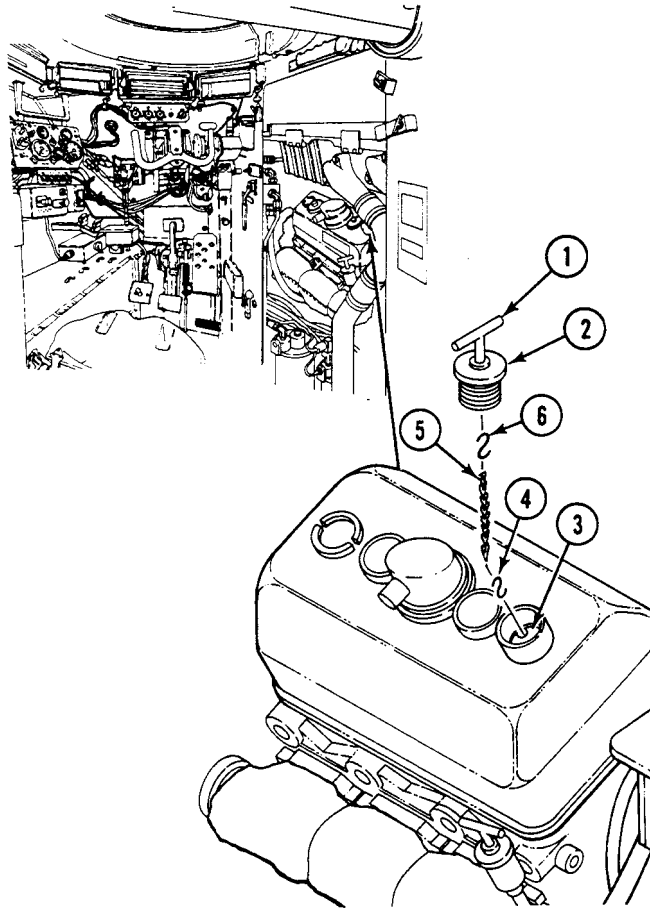

INSTALLATION

1. Secure chain (5) to new filler cap (2) with new hook (6).
2. Secure other end of chain (5) to filler hole (3) with new hook (4).
3. Install cap (2) in filler hole (3) and secure by turning T-handle (1) clockwise.

FOLLOW-THROUGH STEPS

1. Install driver's power plant access panel (see your -10).

END OF TASK

REPLACE ENGINE OIL SAMPLING VALVE AND HOSE

0163 00

THIS WORK PACKAGE COVERS:

Removal (page 0163 00-1).
 Installation (page 0163 00-2).

INITIAL SETUP:

Maintenance Level

Unit

References

See your -10

Tools and Special Tools

General Mechanic's Tool Kit (WP 0926 00, Item 65)

Equipment Condition

Engine stopped (see your -10)

Carrier blocked (see your -10)

Materials/Parts

Sealing compound (WP 0928 00, Item 56)

Driver's power plant access panel removed
 (see your -10)

Personnel Required

Unit Mechanic

REMOVAL

1. Remove hose (1) from adapter (2).
2. Remove hose (1) from elbow (3).
3. Loosen jam nut (4) on valve (5) and slide valve out of bracket (6).
4. Remove elbow (3) from bushing (7).
5. Remove bushing (7) from valve (5).

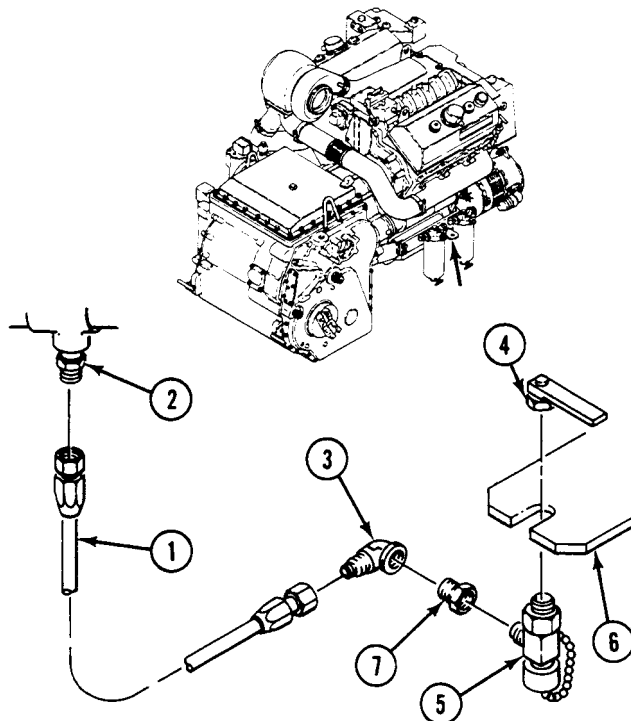

INSTALLATION

1. Apply sealing compound to all male tapered threads. Do not apply sealing compound beyond small end of tapered threads.
2. Install bushing (7) in valve (5).
3. Install elbow (3) in bushing (7).
4. Install valve (5) on bracket (6) and secure with jam nut (4).
5. Install hose (1) on elbow (3).
6. Route hose behind fuel filter and connect hose (1) to adapter (2).

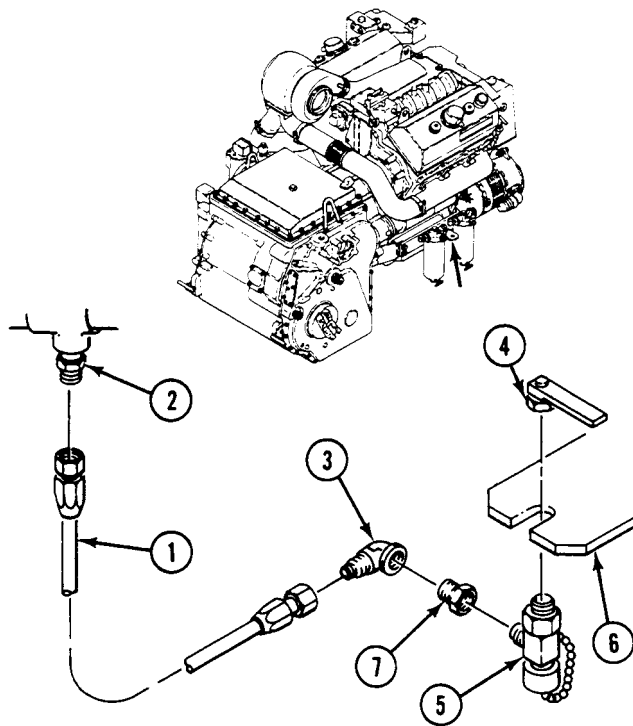
**FOLLOW-THROUGH STEPS**

1. Start engine (see your -10).
2. Check for leaks.
3. Stop engine (see your -10).
4. Install driver's power plant access panel (see your -10).

END OF TASK

REPLACE OIL GAUGE ROD AND TUBE

0164 00

THIS WORK PACKAGE COVERS:

Removal (page 0164 00-1).
 Installation (page 0164 00-2).

INITIAL SETUP:

Maintenance Level

Unit

References

See your -10

Tools and Special Tools

General Mechanic's Tool Kit (WP 0926 00, Item 65)

Equipment Condition

Materials/Parts

Adhesive (WP 0928 00, Item 4)

Locknut

Engine stopped (see your -10)

Carrier blocked (see your -10)

Personnel Required

Unit Mechanic

Driver's power plant access panel removed
 (see your -10)

REMOVAL

1. Loosen oil gauge rod tee handle (1). Remove oil gauge rod (2) from tube (3).
2. Remove locknut (4), clamp (5), and washer (6) from engine. Discard locknut.
3. Loosen nut (7). Remove tube (3) and clamp (5) from oil pan adapter (8).

- Remove adapter (8) from oil pan (9).

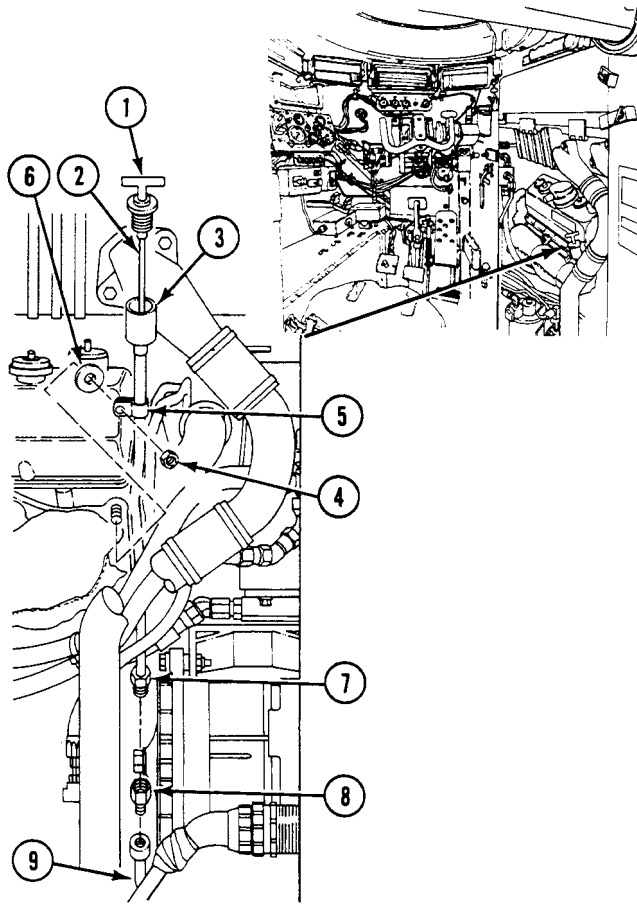

INSTALLATION

- Apply a thin coat of adhesive to external threads of nut (7) and adapter (8).
- Install adapter (8) on oil pan (9).
- Install tube (3) and clamp (5) on oil pan adapter (8). Tighten nut (7).
- Install washer (6), clamp (5) and tube (3) on engine. Secure with new locknut (4).
- Install oil gauge rod (2) in tube (3). Tighten oil gauge rod tee handle (1).

FOLLOW-THROUGH STEPS

- Install driver's power plant access panel (see your -10).

END OF TASK

REPLACE OIL FILTER ELEMENT

0165 00

THIS WORK PACKAGE COVERS:

- Removal (page 0165 00-1).
 - Cleaning (page 0165 00-1).
 - Installation (page 0165 00-2).
-

INITIAL SETUP:

Maintenance Level

Unit

References

See your -10

Tools and Special Tools

- General Mechanic's Tool Kit (WP 0926 00, Item 65)
- Oil filter wrench (WP 0926 00, Item 76)

Materials/Parts

- Cleaning compound (WP 0928 00, Item 19)
- Wiping rag (WP 0928 00, Item 65)

Equipment Condition

- Engine stopped (see your -10)
- Carrier blocked (see your -10)

Personnel Required

Unit Mechanic

Power plant bottom access cover removed (WP 0450 00)

REMOVAL

1. Remove engine oil filter element (1) from adapter (2) and bracket (3). Discard filter element per Unit SOP.

CLEANING

1. Clean surface of filter housing (4) with cleaning compound and wiping rags.

INSTALLATION

1. Install engine oil filter element (1) on adapter (2) and bracket (3).

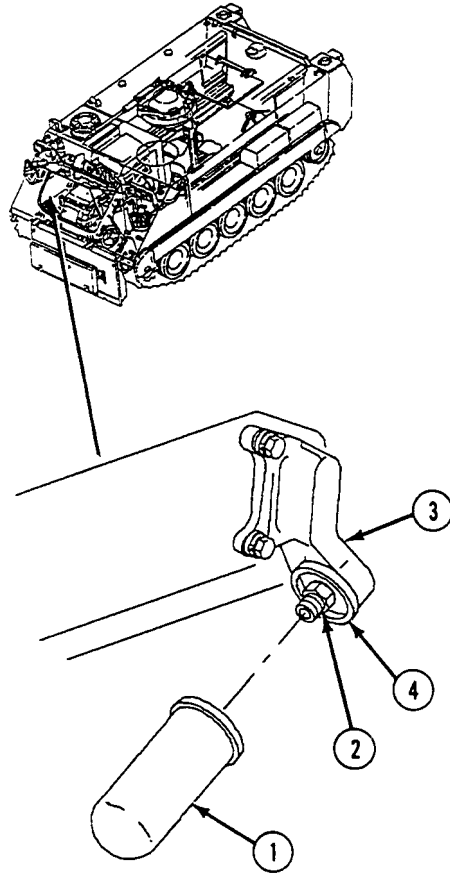
**FOLLOW-THROUGH STEPS**

1. Start engine (see your -10). Check for leaks.
2. Stop engine (see your -10).
3. Install power plant bottom access cover (WP 0450 00).

END OF TASK

CHAPTER 5

UNIT MAINTENANCE INSTRUCTIONS
FOR FUEL SYSTEM

WORK PACKAGE INDEX

<u>Title</u>	<u>Sequence No.</u>
REPLACE ENGINE FUEL PUMP.....	0166 00
SERVICE AIR CLEANER FILTER ELEMENT.....	0167 00
REPLACE AIR CLEANER AND ELBOW.....	0168 00
REPAIR AIR CLEANER ASSEMBLY.....	0169 00
REPAIR AIR CLEANER RETAINER.....	0170 00
REPLACE AIR CLEANER RESTRICTION INDICATOR.....	0171 00
REPLACE AIR CLEANER RESTRICTION INDICATOR HOSE.....	0172 00
REMOVE/INSTALL AIR INTAKE ELBOW.....	0173 00
REPLACE GRILL AIR INTAKE ELBOW AND HOSE.....	0174 00
REPLACE EXHAUST EVACUATOR VALVE AND CONNECTOR.....	0175 00
CLEAN FUEL CAP VENT AND FILTER SCREEN.....	0176 00
DRAIN TANKS (ALL EXCEPT M577A3 AND M1068A3).....	0177 00
DRAIN FUEL TANKS (M577A3 AND M1068A3 ONLY).....	0178 00
REPLACE EXTERNAL FUEL TANKS (ALL EXCEPT M577A3 AND M1068A3).....	0179 00
REPLACE FUEL TANKS (M577A3 AND M1068A3 ONLY).....	0180 00
TEMPORARY FUEL TANK REPAIR (M577A3 AND M1068A3 ONLY).....	0181 00
REPLACE FUEL TANK FILLER COVER AND LOCK (ALL EXCEPT M577A3 AND M1068A3).....	0182 00
REPLACE FUEL TANK FILLER COVER AND LOCK (M577A3 AND M1068A3 ONLY).....	0183 00
REPLACE FILLER CAP AND STRAINER PARTS (ALL EXCEPT M577A3 AND M1068A3).....	0184 00
REPLACE FILLER CAP AND STRAINER PARTS (M577A3 AND M1068A3 ONLY).....	0185 00
REPLACE FUEL FILLER AND STRAINER PARTS (M577A3 AND M1068A3 ONLY).....	0186 00
REPLACE FUEL TANK ACCESS COVERS AND DRAIN PLUGS (ALL EXCEPT M577A3 AND M1068A3).....	0187 00
REPLACE FUEL TANK ACCESS COVERS (M577A3 AND M1068A3 ONLY).....	0188 00
REPLACE FUEL TANK FILLER FLANGE (M577A3 AND M1068A3 ONLY).....	0189 00
REPLACE FUEL QUANTITY TRANSMITTER (ALL EXCEPT M577A3 AND M1068A3).....	0190 00
REPLACE FUEL QUANTITY TRANSMITTER (M577A3 AND M1068A3 ONLY).....	0191 00
REPLACE FUEL SUPPLY HOSES, TUBES, AND FITTINGS (M113A3, M1059A3, AND M58 ONLY).....	0192 00
REPLACE FUEL SUPPLY HOSES, TUBES, AND FITTINGS (M577A3 AND M1068A3 ONLY).....	0193 00
REPLACE FUEL SUPPLY HOSES, TUBES, AND FITTINGS (M1064A3 ONLY).....	0194 00
REPLACE FUEL RETURN HOSES, TUBES, AND FITTINGS (M113A3, M1059A3, AND M58 ONLY).....	0195 00
REPLACE FUEL RETURN HOSES, TUBES, AND FITTINGS (M577A3 AND M1068A3 ONLY).....	0196 00
REPLACE FUEL RETURN HOSES, TUBES, AND FITTINGS (M1064A3 ONLY).....	0197 00
REPLACE FUEL VENT HOSES, TUBES, AND FITTINGS (M577A3 AND M1068A3 ONLY).....	0198 00

CHAPTER 5

UNIT MAINTENANCE INSTRUCTIONS
FOR FUEL SYSTEM

WORK PACKAGE INDEX (Continued)

<u>Title</u>	<u>Sequence No.</u>
REPLACE FUEL VALVE MOUNTING BLOCKS (ALL EXCEPT M577A3 and M1068A3).....	0199 00
REPLACE ENGINE FUEL SUPPLY HOSE.....	0200 00
REPLACE ENGINE FUEL RETURN HOSE.....	0201 00
REPLACE PRIMARY AND SECONDARY FUEL FILTER ELEMENTS.....	0202 00
REPLACE PRIMARY AND SECONDARY FUEL FILTERS AND BRACKET.....	0203 00
REPLACE AIR BOX HEATER IGNITION WIRE.....	0204 00
REPLACE AIR BOX HEATER WIRING HARNESS.....	0205 00
REPLACE AIR BOX HEATER LOWER FUEL LINE.....	0206 00
REPLACE AIR HEATER IGNITER.....	0207 00
REPLACE AIR BOX IGNITION COIL.....	0208 00
REPLACE GLOW PLUG HARNESS AND GLOW PLUGS.....	0209 00
REPLACE GLOW PLUG CONTROLLER.....	0210 00
REPLACE GLOW PLUG POWER HARNESS.....	0211 00
REPLACE GLOW PLUG CONTROLLER MOUNTING BRACKET.....	0212 00
ADJUST THROTTLE VALVE (TV) MODULATOR.....	0213 00
ADJUST ACCELERATOR LINKAGE.....	0214 00
REPLACE LOWER ACCELERATOR PEDAL.....	0215 00
REPLACE UPPER ACCELERATOR PEDAL ASSEMBLY.....	0216 00
REPLACE FUEL CONTROL SHAFT AND LINKAGE.....	0217 00
REPLACE THROTTLE VALVE (TV) MODULATOR AND LEVER.....	0218 00
REPLACE HAND THROTTLE CONTROL CABLE ASSEMBLY.....	0219 00
REPLACE FUEL CUTOFF CONTROL CABLE ASSEMBLY.....	0220 00

REPLACE ENGINE FUEL PUMP

0166 00**THIS WORK PACKAGE COVERS:**

Removal (page 0166 00-1).
 Clean (page 0166 00-2).
 Inspect (page 0166 00-3).
 Repair (page 0166 00-3).
 Installation (page 0166 00-4).

INITIAL SETUP:Maintenance Level

Unit

Tools and Special Tools

General Mechanic's Tool Kit (WP 0926 00, Item 65)

Materials/Parts

Adhesive (WP 0928 00, Item 4)
 Cleaning compound (WP 0928 00, Item 19)
 Gasket

Personnel Required

Unit Mechanic

References

See your -10

Equipment Condition

Engine stopped (see your -10)
 Carrier blocked (see your -10)
 Trim vane lowered (see your -10)
 Power plant upper rear access panel removed
 (see your -10)
 Front power plant access door open (see your -10)
 Battery ground strap disconnected (WP 0337 00),
 (WP 0338 00), or (WP 0339 00)
 Left exhaust elbow removed (WP 0225 00)

REMOVAL**CAUTION**

Install covers on disconnected fuel lines, tubes, valves and components during maintenance. Use tape, cloth, cardboard, or any appropriate material to prevent damage to components or accidental fuel spills.

1. Remove fuel supply hose (1) at quick disconnect (2).
2. Remove fuel return hose (3) at quick disconnect (4).
3. Remove fuel supply hose (5) from elbow (6).
4. Remove elbow (6) from fuel pump (7).
5. Remove fuel supply hose (8) from elbow (9).
6. Remove elbow (9) from fuel pump (7).

7. Remove three screws (10), fuel pump (7), gasket (11), and fork (12) from engine block. Discard gasket.

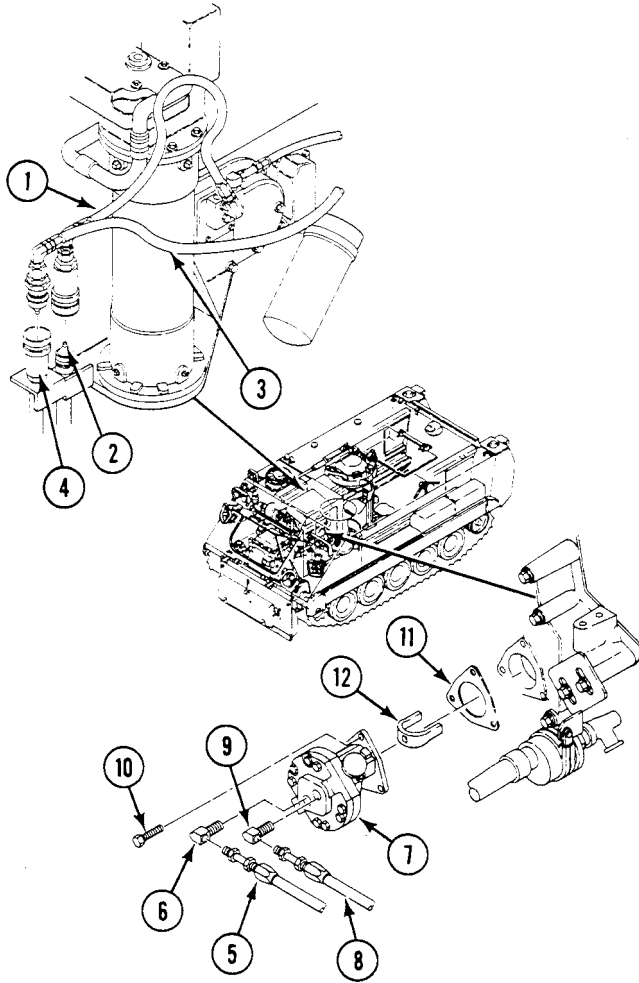

CLEANING

1. Clean fuel pump (1) and fittings with cleaning compound.

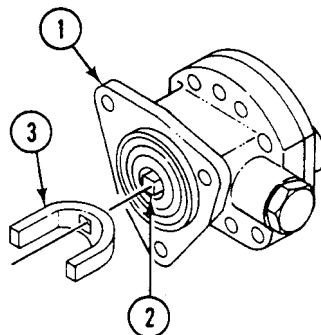

INSPECTION-ACCEPTANCE AND REJECTION CRITERIA

1. Check pump body (1).
2. Check end of shaft (2)
3. Check fork (3).

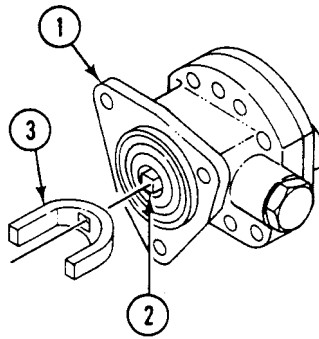
**REPAIR OR REPLACEMENT**

1. Replace pump body (1) if damaged.
2. Replace shaft (2) that is worn or does not rotate smoothly.
3. Replace fork (3) if worn or damaged.

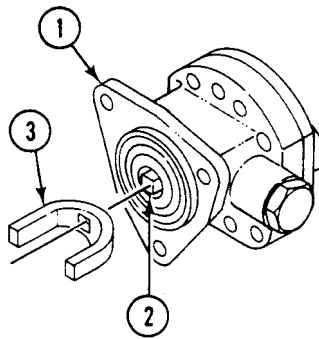

INSTALLATION

1. Apply adhesive to external threads of hoses (4)(5) and elbows (6)(7).
2. Install fork (3), new gasket (8), fuel pump (1) and three screws (9) on engine block.
3. Install elbow (7) in fuel pump (1).
4. Install fuel supply hose (5) on elbow (7).
5. Install elbow (6) in fuel pump (1).
6. Install fuel supply hose (4) on elbow (6).
7. Install fuel supply hose (10) at quick disconnect (11).
8. Install fuel return hose (12) at quick disconnect (13).

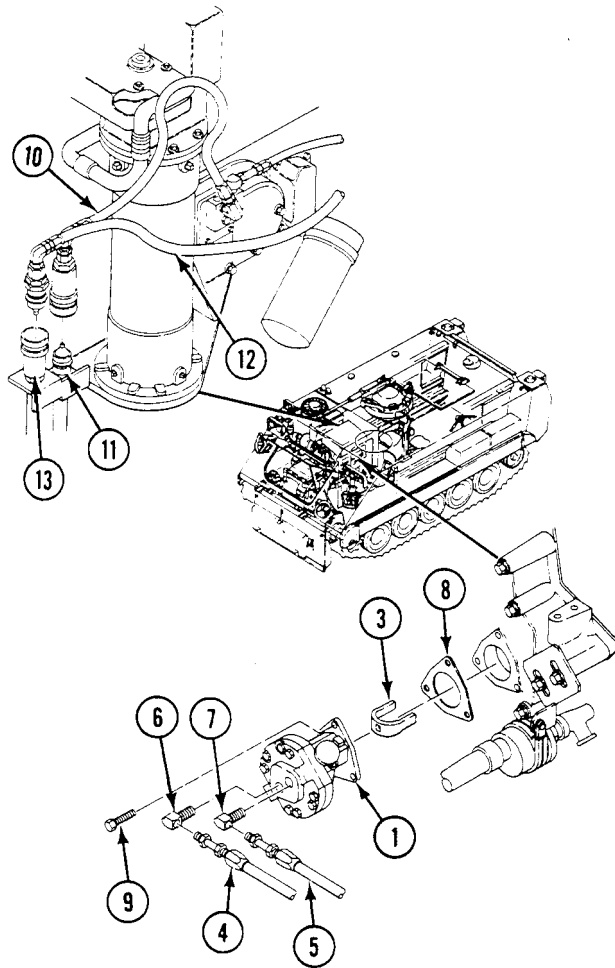

FOLLOW-THROUGH STEPS

1. Install left exhaust elbow (WP 0225 00).
2. Connect battery ground strap (WP 0337 00), (WP 0338 00), or (WP 0339 00).

WARNING

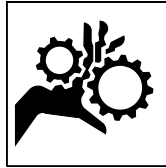

Start up of equipment or moving parts can injure you. Stay clear of moving parts when power unit is running.

3. Start engine (see your -10). Check for leaks. Check for correct fuel pump operation.
4. Stop engine (see your -10).
5. Install power plant upper rear access panel (see your -10).
6. Close power plant access door (see your -10).
7. Raise trim vane (see your -10).

END OF TASK

SERVICE AIR CLEANER FILTER ELEMENT

0167 00

THIS WORK PACKAGE COVERS:

Servicing (page 0167 00-1).

INITIAL SETUP:

Maintenance Level

Unit

References

See your -10

Tools and Special Tools

General Mechanic's Tool Kit (WP 0926 00, Item 65)
Suitable Container

Equipment Condition

Engine stopped (see your -10)

Materials/Parts

Detergent (WP 0928 00, Item 35)

Carrier blocked (see your -10)

Personnel Required

Unit Mechanic

Air cleaner element removed (see your -10)

SERVICING

WARNING

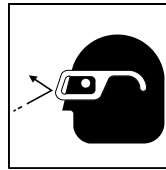

Air pressure in excess of 30 psi (207 kpa) can injure personnel. Do not direct pressurized air at yourself or others. Always wear goggles.

NOTE

Cleaning air filter element may be cleaned by either or both of the following methods.

1. Using air gun, blow out element with 30 psi (206 kpa) maximum compressed air from inside to outside of element (in direction opposite to normal air flow).

2. Wash element in solution of nonsudsing or low sudsing detergent and water or soap and water. Do not use gasoline or solvents for cleaning.
 - a. Prepare solution of 1 cup of dry detergent to 5 gallons of water in a container large enough to completely submerge the element. The temperature of the solution should not exceed 190°F (88°C). Make solution stronger if element is extremely dirty.
 - b. Immerse element completely in the washing solution. Agitate element gently for 2 minutes.
 - c. Allow element to soak in solution for a minimum of 15 minutes. Agitate element gently for an additional 3 to 5 minutes.
 - d. Remove element from solution and allow to drain.
 - e. Rinse element with cold water from a hose with a maximum 45 psi (310 kpa) water pressure from inside to outside of element. Continue rinsing until water runs clear and detergent or soap residue is removed from element.
 - f. Allow element to air dry thoroughly.

FOLLOW-THROUGH STEPS

1. Install air cleaner element (see your -10).

END OF TASK

REPLACE AIR CLEANER AND ELBOW

0168 00

THIS WORK PACKAGE COVERS:

Removal (page 0168 00-2).
 Installation (page 0168 00-7).

INITIAL SETUP:

Maintenance Level

Unit

Personnel Required

Unit Mechanic

Tools and Special Tools

General Mechanic's Tool Kit (WP 0926 00, Item 65)
 Torque Adapter (WP 0926 00, Item 1)
 Torque Wrench (WP 0926 00, Item 85)
 Torque Wrench (WP 0926 00, Item 86)

References

TM 9-2350-277-10

Materials/Parts

Lockwasher (2)
 Lockwasher (3)
 Locknut (10)
 Resilient mount (2)
 Tie strap
 Decal

Equipment Condition

Engine stopped (see your —10)
 Carrier blocked (see your —10)
 Power plant grill raised (WP 0464 00)

REMOVAL

1. Disconnect two hoses (1) from elbows (2) on air cleaner elbow (3). Remove two elbows (2) from tee (4).
2. Remove tee (4) from air cleaner elbow (3).
3. Remove tie strap (5) securing two hoses (1) to air duct (6). Discard tie strap.

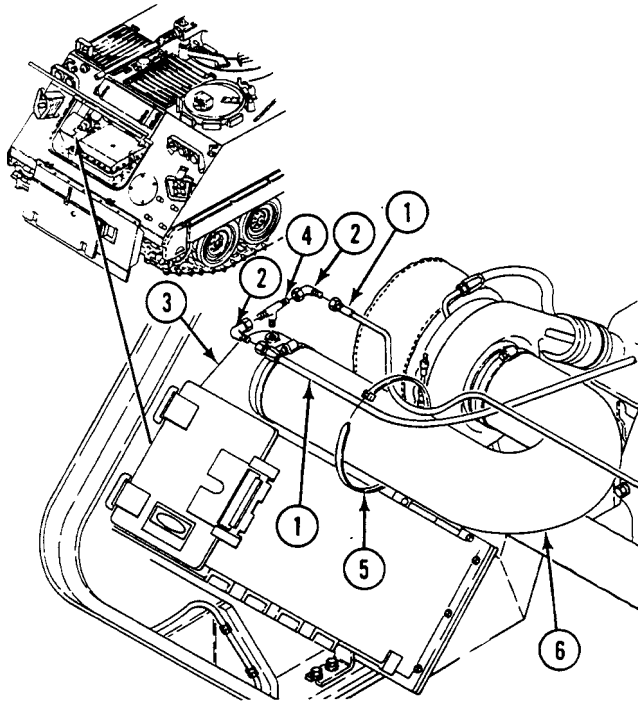

4. Loosen two clamps (1) securing air duct (2) to air cleaner elbow (3) and turbocharger (4).
5. Remove air duct (2) from air cleaner elbow (3) and turbocharger (4).

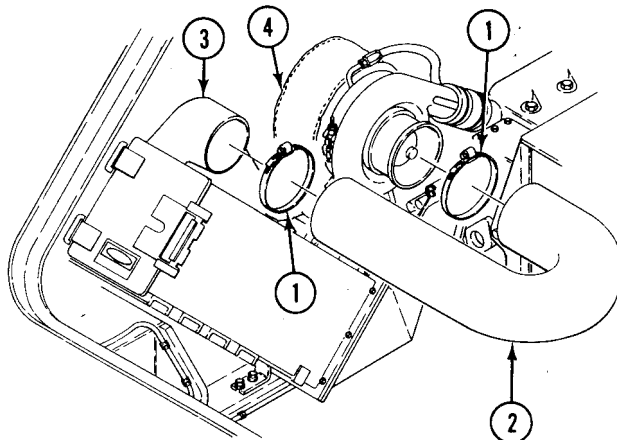

6. Remove two clamps (5) from right exhaust elbow (6). Remove exhaust elbow from exhaust manifold (7) and turbocharger inlet (8).

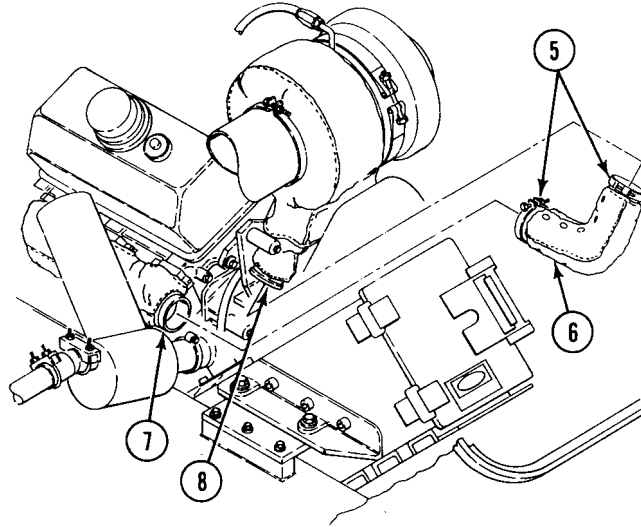

7. Loosen two clamps (9) securing hose (10) to air cleaner lower elbow (11) and exhaust evacuator valve (12).
8. Loosen clamp (13) securing evacuator valve (12) to connector (14). Move valve towards air cleaner elbow and remove valve.
9. Remove clamp (15) and duct (16) from air cleaner elbow (17).

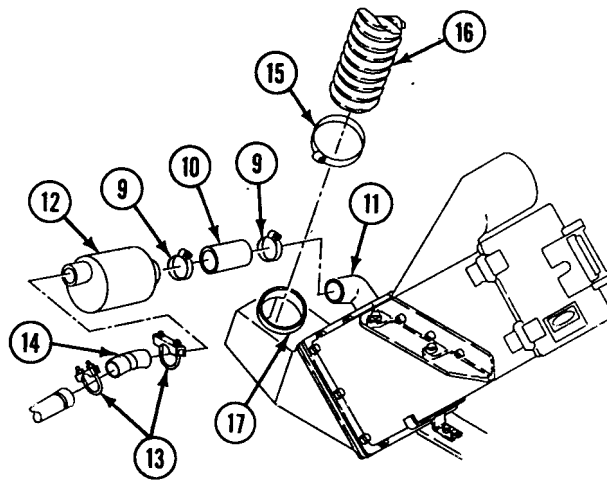

10. Open and remove air cleaner door (18).
11. Release air cleaner element retainer (19) and remove air cleaner element (20).

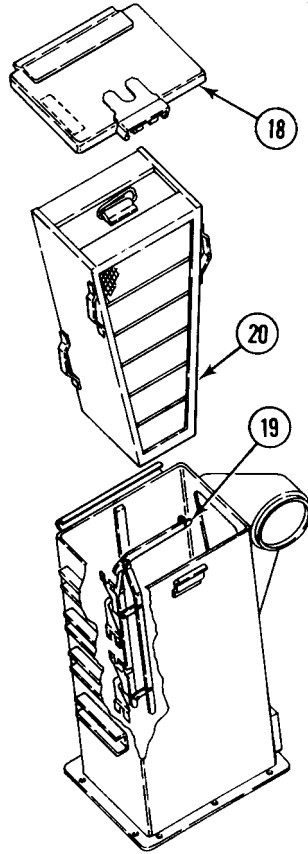

12. Remove three screws (1) and washers (2) securing bracket (3) to air cleaner (4).
13. Remove three screws (5), washers (6), and bracket (3) and (7) from sponson (8).

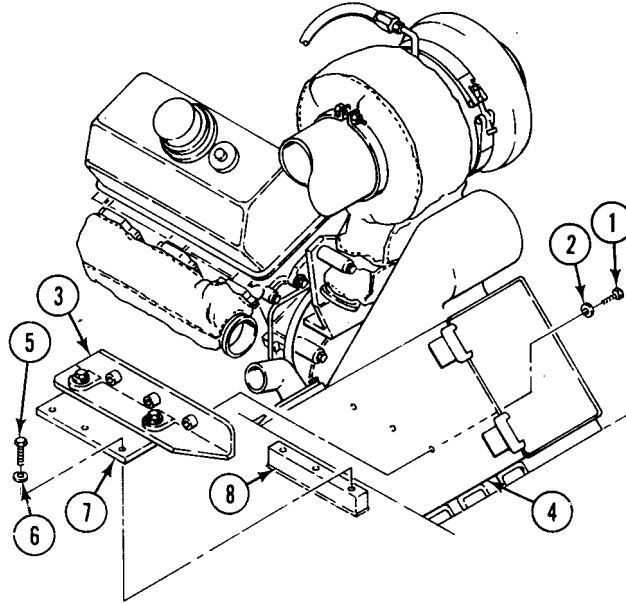

14. Remove two screws (9), lockwashers (10), washers (11), and air cleaner support (12) from box beam. Discard lockwashers.
15. Remove air cleaner (4) from carrier.

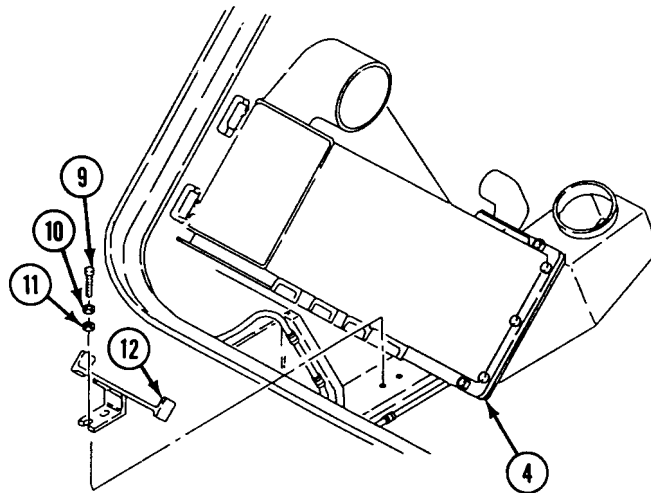

16. Remove three screws (13), lockwashers (14), washers (15), and adapter (16) from air cleaner (4). Discard lockwashers.

NOTE

The four screws at the top and bottom edges of the air cleaner flange are installed with heads down and nuts at top.

17. Remove 10 screws (17), 20 washers (18), 10 locknuts (19), and elbow (20) from air cleaner (4). Discard locknuts.

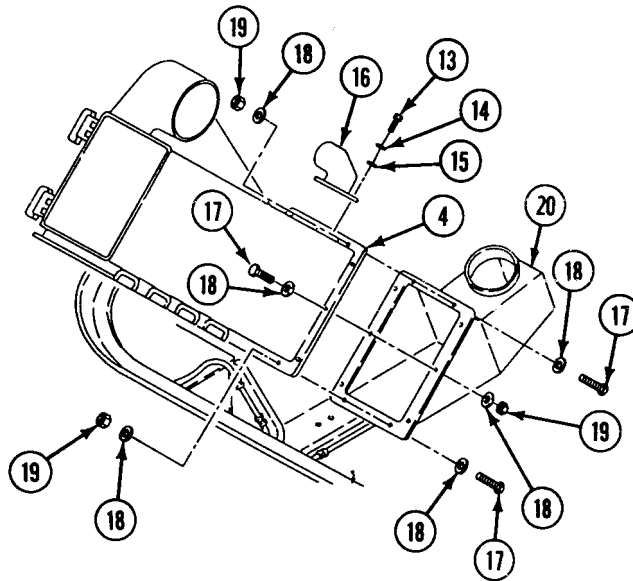

NOTE

Separate brackets only if damaged.

18. Remove two screws (21), washers (22), and resilient mounts (23) from air cleaner bracket (3) and sponson bracket (7). Discard damaged bracket and resilient mounts.

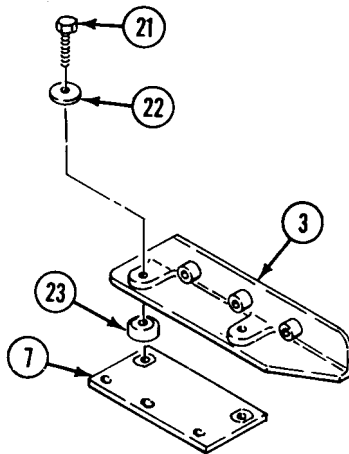

INSTALLATION

NOTE

If separated, reassemble brackets.

1. Lubricate two new resilient mounts (1) with water. Secure air cleaner bracket (2), sponson bracket (3), and two mounts (1) with two screws (4) and washers (5). Do not tighten screws.

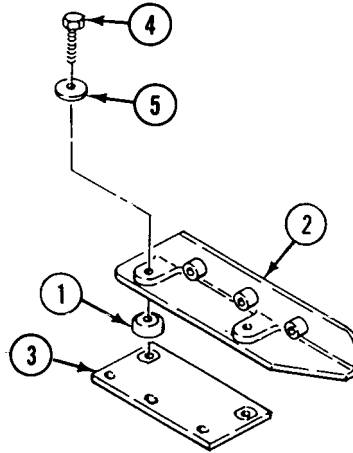

NOTE

The four screws at the top and bottom edges of the air cleaner flange must be installed with heads down and nuts at top.

2. Install elbow (6) on air cleaner (7) and secure with 10 screws (8), 20 washers (9), and 10 new locknuts (10).
3. Install adapter (11) on air cleaner (7) and secure with three screws (12), new lockwashers (13), and washers (14).

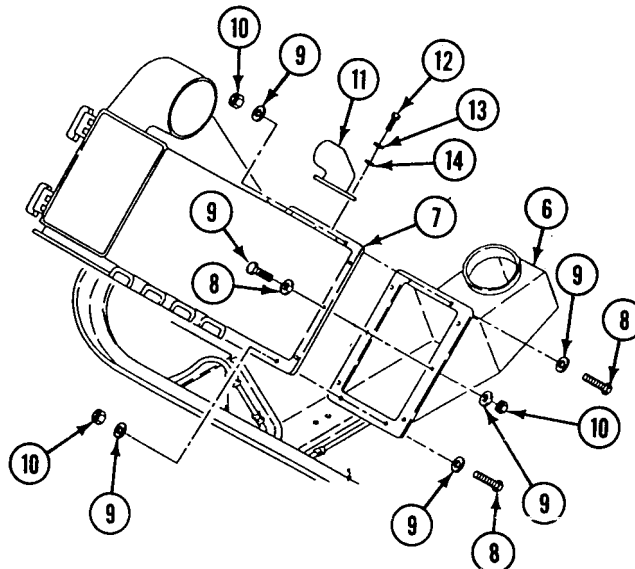

4. Position air cleaner (7) in engine compartment.
5. Position air cleaner support (15) on box beam and secure with two screws (16), new lockwashers (17), and washers (18).

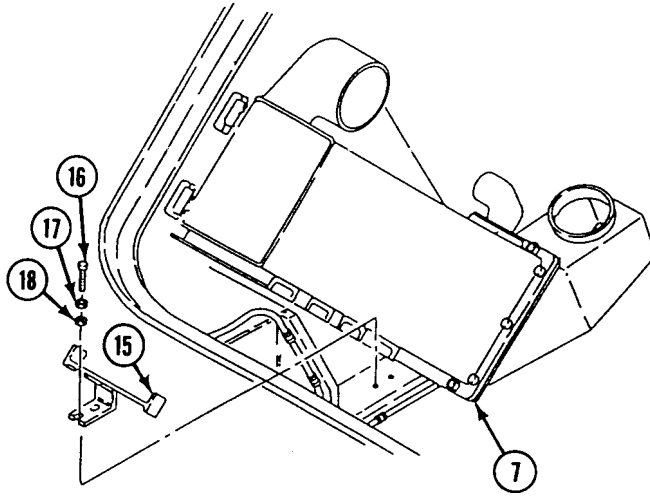

6. Install brackets (1) and (2) on sponson (3) and secure with three screws (4) and washers (5). TIGHTEN THREE SCREWS TO 32-34 LB-FT (43-46 N·m) TORQUE.
7. Position air cleaner (6) and air cleaner bracket (1). Secure bracket to air cleaner with three screws (7) and washers (8). TIGHTEN THREE SCREWS TO 32-34 LB-FT (43-46 N·m) TORQUE.
8. TIGHTEN TWO SCREWS (9) TO 25-27 LB-FT (34-37 N·m) TORQUE.

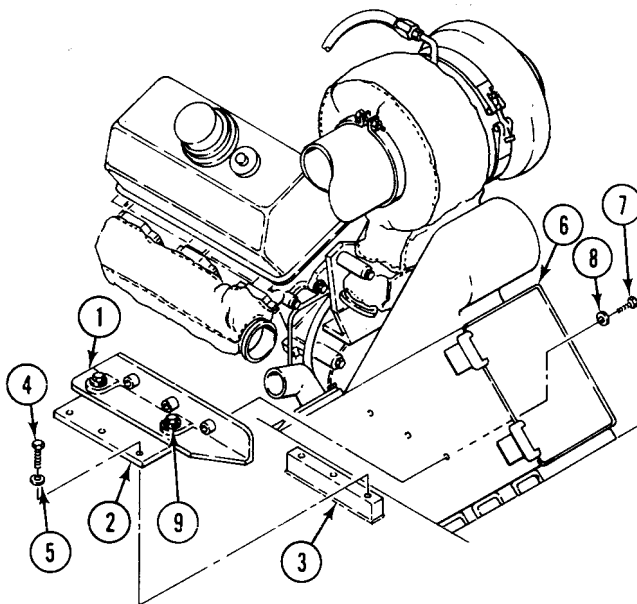

9. Install air cleaner element (10) and reset retainer (11).

NOTE

Install new decal (WP 0644 00) if door is to be replaced. ■

10. Install air cleaner door (12) on air cleaner.

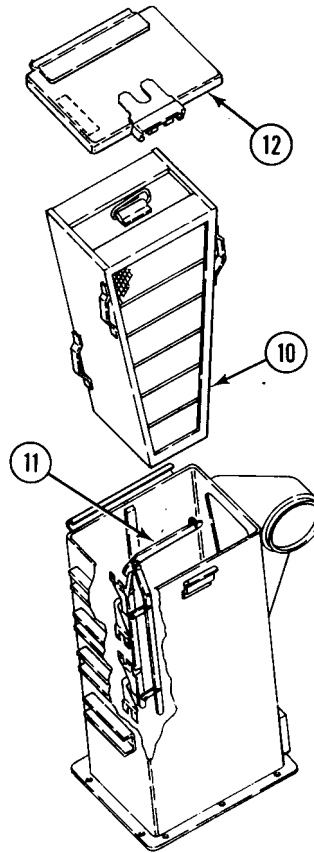

REPLACE AIR CLEANER AND ELBOW — Continued

0168 00

11. Install clamp (13) and duct (14) on air cleaner elbow (15).
12. Position exhaust evacuator valve (16) and hose (17) on elbow (18) and connector (19).
13. Align evacuator valve (16) as indicated on top of valve and tighten two clamps (20) on hose (17).
14. Install and tighten clamp (21) on connector (19).

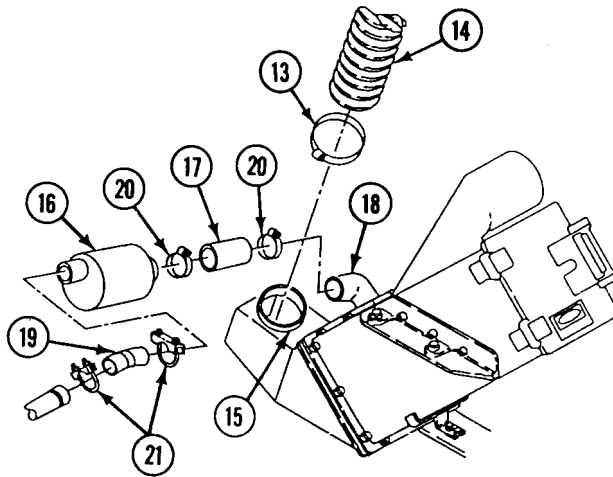

15. Install right exhaust elbow (1) on engine exhaust manifold (2) and turbocharger inlet (3). Secure with two clamps (4).

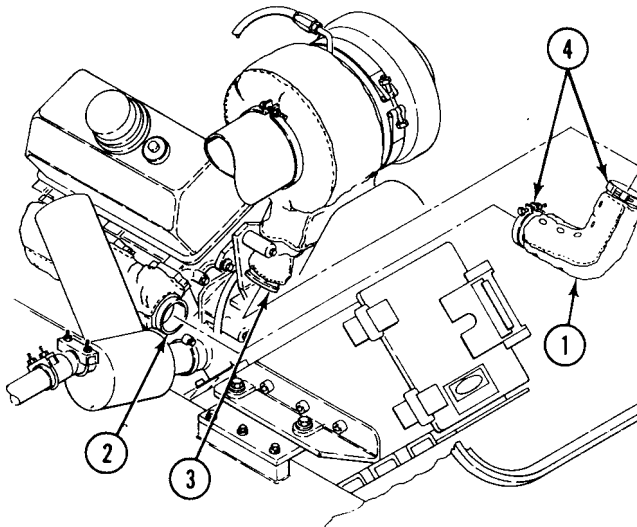

16. Install air duct (5) between air cleaner elbow (6) and turbocharger (7). Secure air duct with two clamps (8).

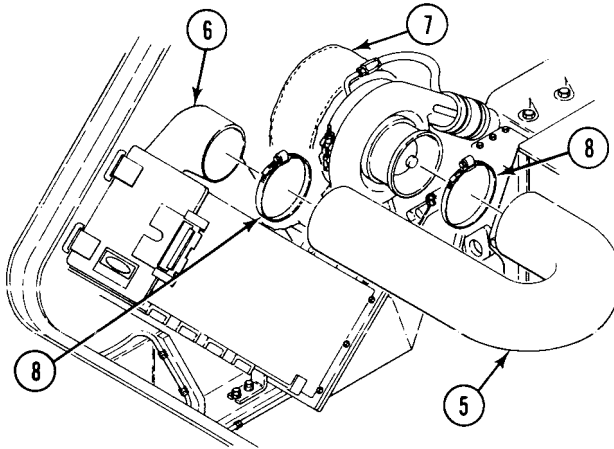

17. Install tee (9) in air cleaner elbow (6). Install two elbows (10) on tee and connect two hoses (11) to elbows. Secure two hoses to air duct (5) with new tie strap (12).

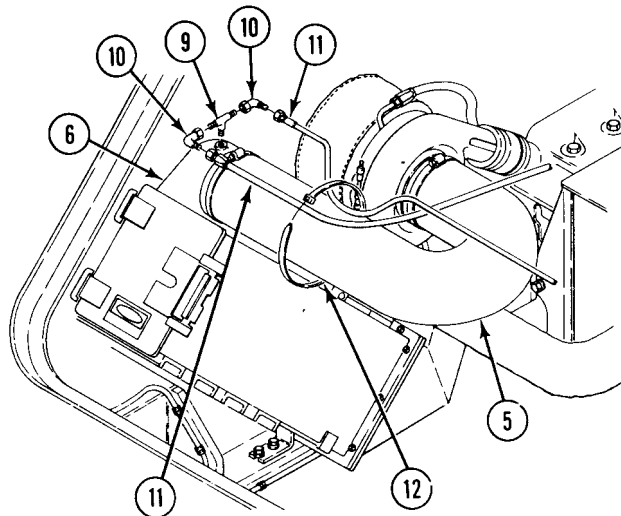

FOLLOW-THROUGH STEPS

1. Lower power plant grill (WP 0464 00).

END OF TASK

REPAIR AIR CLEANER ASSEMBLY

0169 00

THIS WORK PACKAGE COVERS:

Removal (page 0169 00-1).
 Installation (page 0169 00-2).

INITIAL SETUP:

Maintenance Level

Unit

References

See your -10

Tools and Special Tools

General Mechanic's Tool Kit (WP 0926 00, Item 65)

Equipment Condition

Engine stopped (see your -10)

Materials/Parts

Adhesive (WP 0928 00, Item 4)

Gasket

Carrier blocked (see your -10)

Personnel Required

Unit Mechanic

Trim vane lowered (see your -10)

Power plant front access door opened (see your -10)

REMOVAL

1. Remove door (1) from air cleaner (2).
2. Remove gasket (3) from door (1). Discard gasket.

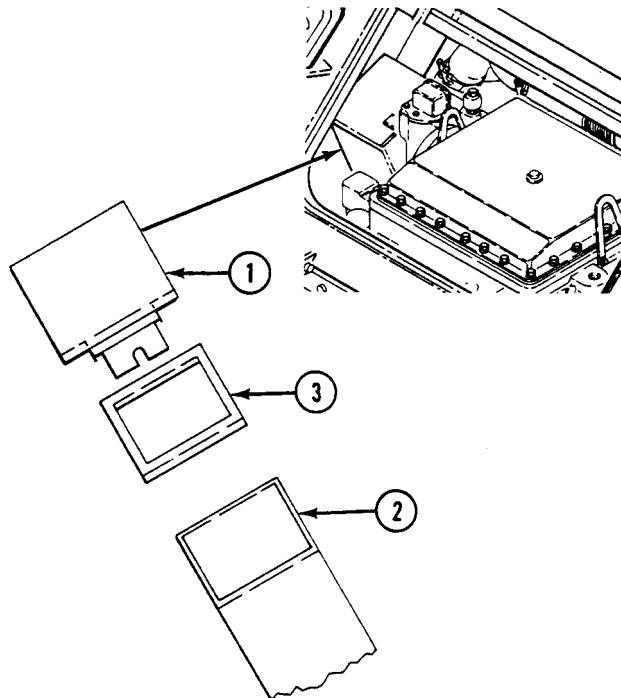

INSTALLATION**NOTE**

Clean area on door before installing new gasket.

1. Apply adhesive to new gasket (3).
2. Install new gasket (3) on door (1).
3. Install door (1) on air cleaner (2).

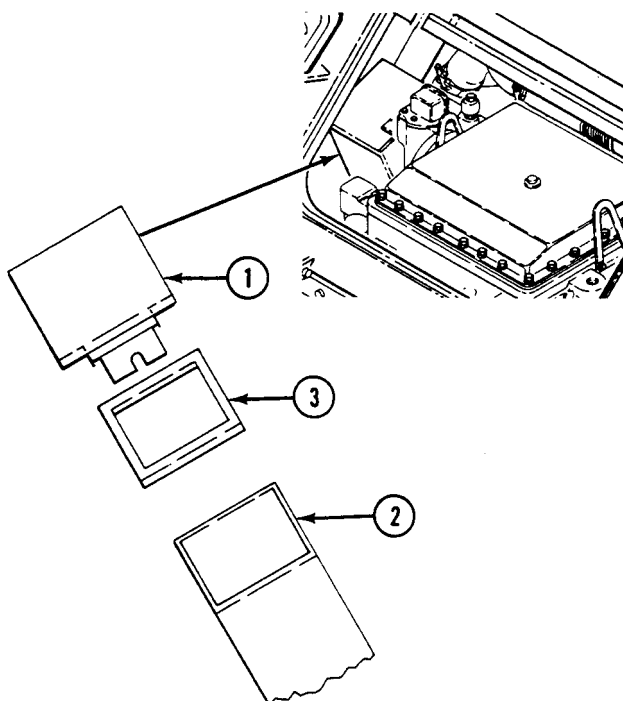
**FOLLOW-THROUGH STEPS**

1. Close power plant front access door (see your -10).
2. Raise trim vane (see your —10).

END OF TASK

REPAIR AIR CLEANER RETAINER

0170 00

THIS WORK PACKAGE COVERS:

- Removal (page 0170 00-1).
- Installation (page 0170 00-1).

INITIAL SETUP:

Maintenance Level

Unit

References

See your -10

Tools and Special Tools

General Mechanic's Tool Kit (WP 0926 00, Item 65)

Equipment Condition

- Engine stopped (see your -10)
- Carrier blocked (see your -10)
- Trim vane lowered (see your -10)
- Power plant front access door open (see your -10)
- Air cleaner door removed (see your -10)

Materials/Parts

Lockwasher (8)

Personnel Required

Unit Mechanic

REMOVAL

1. Release retainer handle (1) and slide out filter element (2).
2. Remove eight nuts (3), lockwashers (4), and screws (5) from retainer (6) and housing (7). Remove retainer from housing. Discard lockwashers.

INSTALLATION

1. Position new retainer (6) into housing (7). Secure with eight screws (5), new lockwashers (4), and nuts (3). Tighten all nuts at this time.

NOTE

Check operation of retainer to make sure there is no binding during operation. If binding occurs, loosen screws and repeat Step 1.

2. Install filter element (2) and reset retainer handle (1).

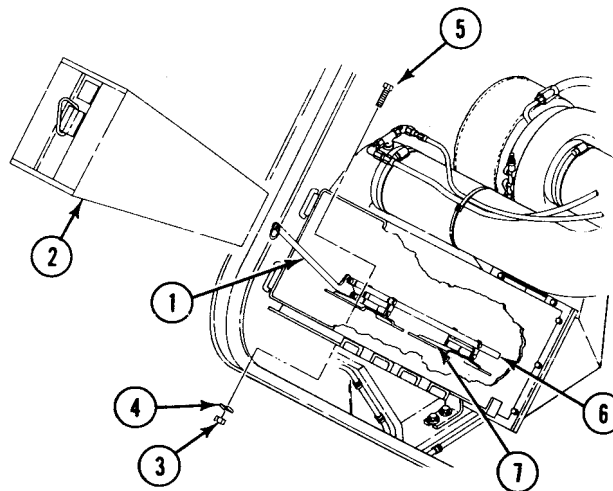

FOLLOW-THROUGH STEPS

1. Install air cleaner door (see your —10).
2. Close power front access door (see your —10).
3. Raise and lock trim vane (see your —10).

END OF TASK

REPLACE AIR CLEANER RESTRICTION INDICATOR

0171 00

THIS WORK PACKAGE COVERS:

Removal (page 0171 00-1).
 Installation (page 0171 00-2).

INITIAL SETUP:

Maintenance Level

Unit

References

See your -10

Tools and Special Tools

General mechanic's tool kit (WP 0926 00, Item 65)

Equipment Condition

Engine stopped (see your -10)

Carrier blocked (see your -10)

Driver's power plant access panel removed
 (see your -10)

Materials/Parts

Locknut (2)

Personnel Required

Unit Mechanic

REMOVAL

1. Remove air cleaner restriction indicator hose (1) from indicator adapter (2). Tape end of hose.
2. Remove two screws (3), four washers (4), and two locknuts (5) from indicator (6). Remove indicator. Discard locknuts. Remove adapter (2) from indicator (6).

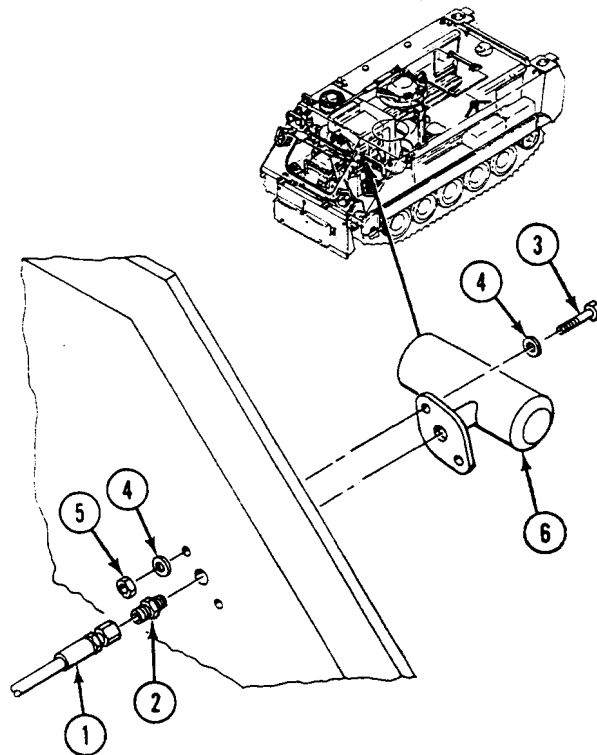

INSTALLATION

1. Remove and reuse the modified adapter (2) with a filter disc. Install adapter (2) in indicator (6).
2. Install restriction indicator (6), two screws (3), four washers (4), and two new locknuts (5).
3. Install hose (1) on indicator adapter (2).

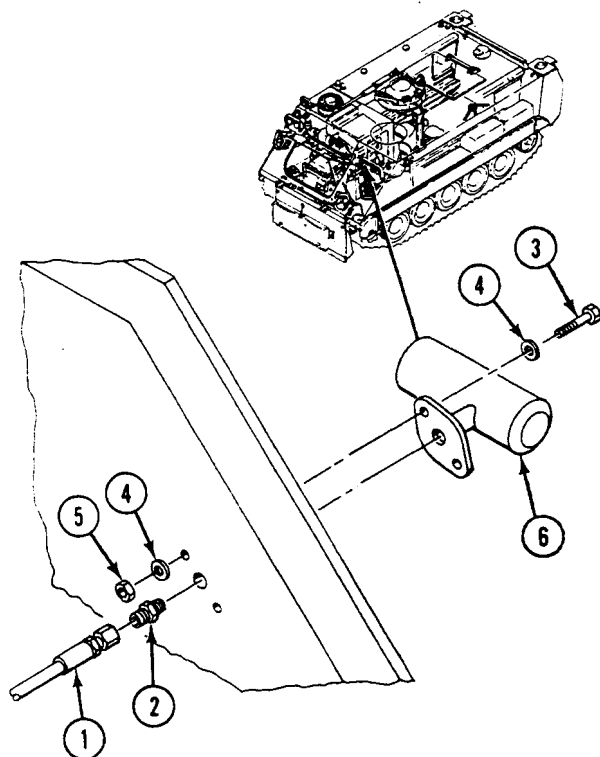
**FOLLOW-THROUGH STEPS**

1. Install driver's power plant access panel (see your -10).

END OF TASK

REPLACE AIR CLEANER RESTRICTION INDICATOR HOSE

0172 00

THIS WORK PACKAGE COVERS:

Removal (page 0172 00-1).
 Installation (page 0172 00-2).

INITIAL SETUP:

Maintenance Level

Unit

References

See your -10

Tools and Special Tools

General mechanic's tool kit (WP 0926 00, Item 65)

Equipment Condition

Engine stopped (see your -10)

Materials/Parts

Sealing compound (WP 0928 00, Item 56)

Strap

Carrier blocked (see your -10)

Personnel Required

Unit Mechanic

Trim vane lowered (see your -10)

Power plant access door open (see your -10)

REMOVAL

1. Disconnect air cleaner restrictor indicator hose (1) from indicator adapter (2).
2. Remove strap (3) from hose (1) and air intake elbow (4). Discard strap.

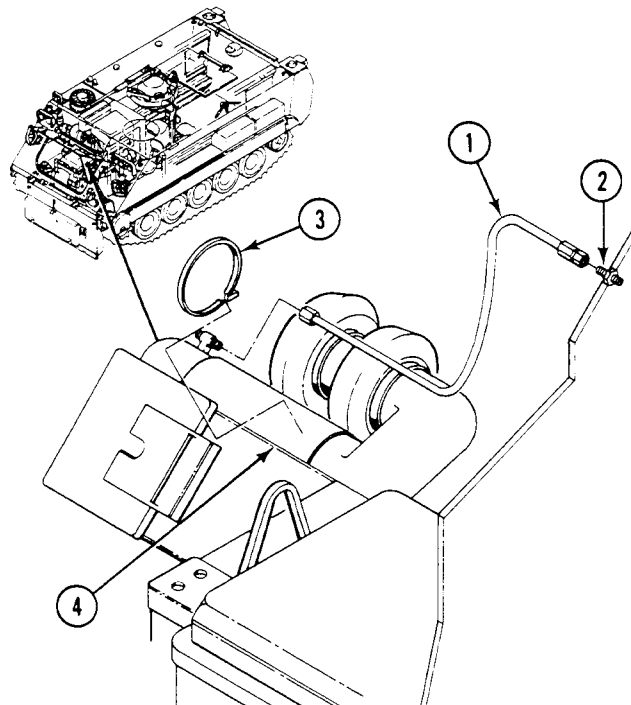

3. Remove hose (1) from reducer (5).
4. Remove nut (6) and reducer (5) from elbow (7).
5. Remove elbow (7) from indicator side of tee (8).
6. Remove hose (9) from elbow (10).
7. Remove tee (8) from reducer (11), and elbow (10).

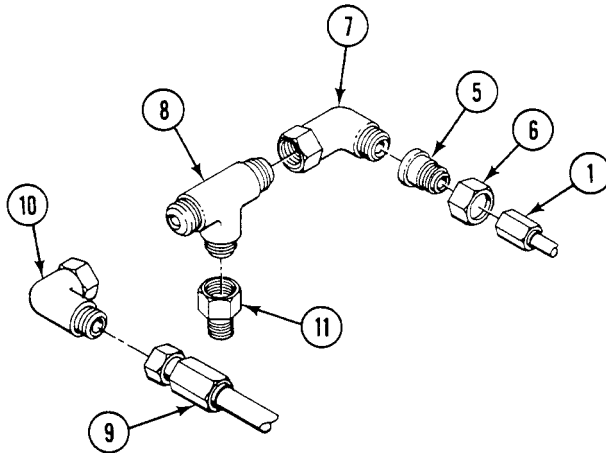

INSTALLATION

1. Apply light coat of sealing compound to pipe threads of tee (1). Install tee on reducer (2).
2. Install elbow (3) on tee (1).
3. Install hose (4) on elbow (3).
4. Install elbow (5) on tee (1).
5. Install reducer (6) and nut (7) on elbow (5).
6. Install hose (8) on reducer (6).

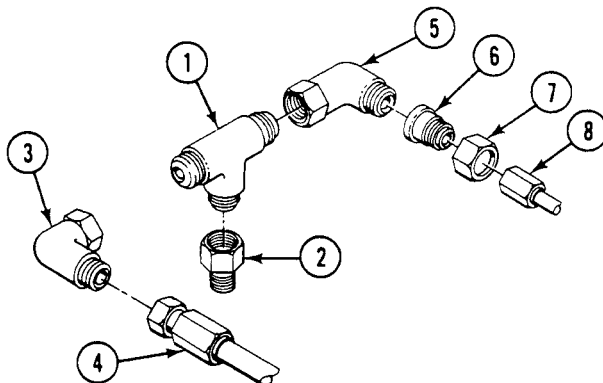

7. Install new strap (9) on hose (8) and elbow (10).
8. Connect hose (8) to indicator adapter (11).

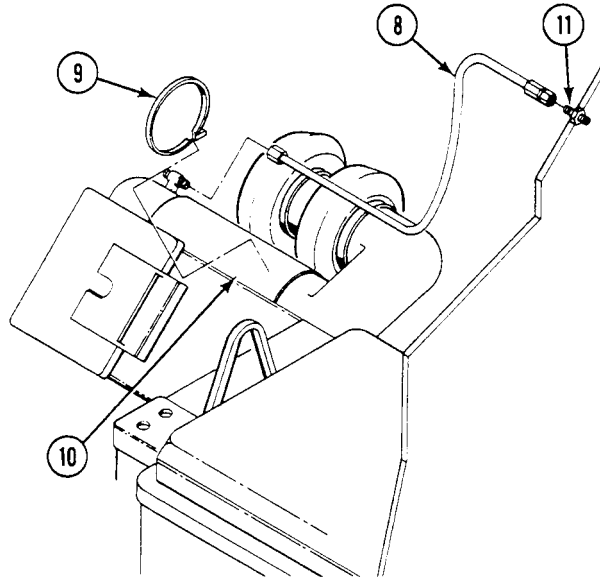
**FOLLOW-THROUGH STEPS**

1. Close power plant front access door (see your -10).
2. Raise trim vane (see your -10).

END OF TASK

REMOVE/INSTALL AIR INTAKE ELBOW

0173 00

THIS WORK PACKAGE COVERS:

Removal (page 0173 00-1).
 Installation (page 0173 00-2).

INITIAL SETUP:

Maintenance Level
 Unit

References
 See your -10

Tools and Special Tools
 General mechanic's tool kit (WP 0926 00, Item 65)

Equipment Condition
 Engine stopped (see your -10)
 Carrier blocked (see your -10)
 Power plant grill raised (WP 0464 00)

Materials/Parts
 Strap

Personnel Required
 Unit Mechanic

REMOVAL

1. Remove strap (1), from air intake elbow (2) and air restriction indicator hose (3). Discard strap.
2. Loosen two clamps (4) and remove air intake elbow (2) from turbocharger inlet (5) and air cleaner (6).

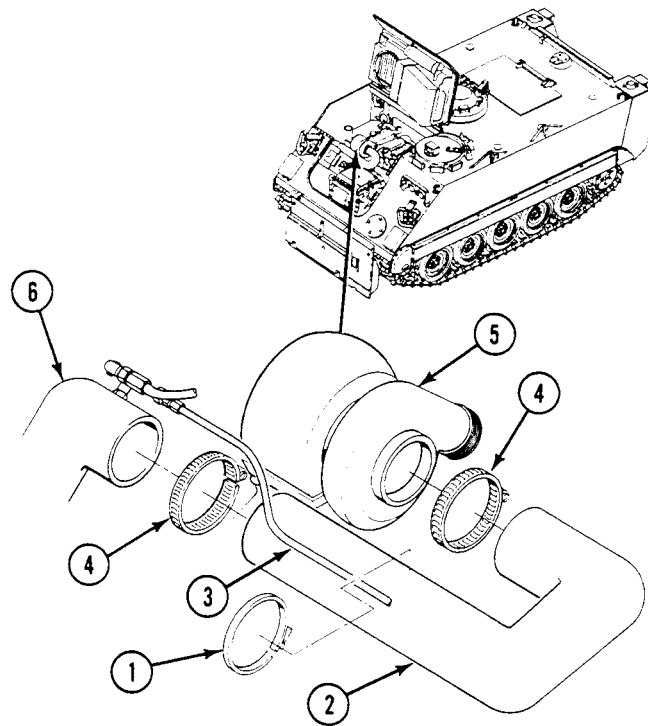

INSTALLATION

1. Install air intake elbow (2) on turbocharger inlet (5) and air cleaner (6). Secure with two clamps (4).
2. Install new strap (1) to secure air restriction hose (3) to air intake elbow (2).

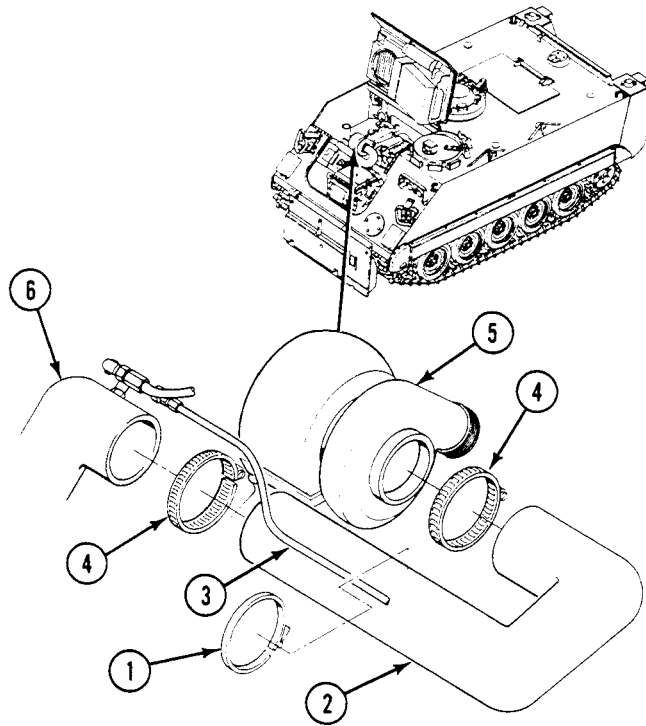
**FOLLOW-THROUGH STEPS**

1. Lower power plant grill (WP 0464 00).

END OF TASK

REPLACE GRILL AIR INTAKE ELBOW AND HOSE

0174 00

THIS WORK PACKAGE COVERS:

Removal (page 0174 00-1).
 Installation (page 0174 00-2).

INITIAL SETUP:

Maintenance Level

Unit

References

See your -10

Tools and Special Tools

General mechanic's tool kit (WP 0926 00, Item 65)

Equipment Condition

Engine stopped (see your -10)
 Carrier blocked (see your -10)
 Power plant grill raised (WP 0464 00)

Personnel Required

Unit Mechanic

REMOVAL

1. Remove two clamps in tandem (1), from elbow (2) and bracket (3) on power plant grill (4).
2. Remove clamp (5) from intake hose (6) and plenum (7).
3. Remove clamp (8) from intake hose (6) and elbow (2).

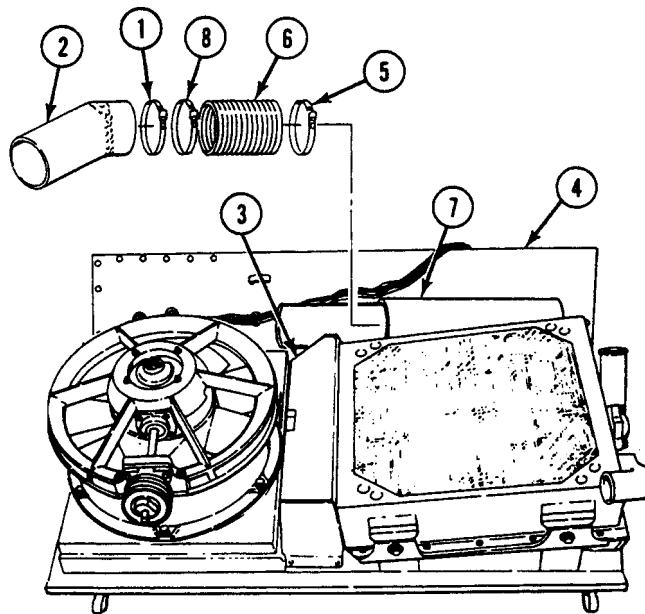

INSTALLATION

1. Install air intake hose (6) on elbow (2). Secure with clamp (8).
2. Install hose (6) on plenum (7). Secure with clamp (5).
3. Secure elbow (2) to bracket (3) on grill (4) with two clamps in tandem (1).

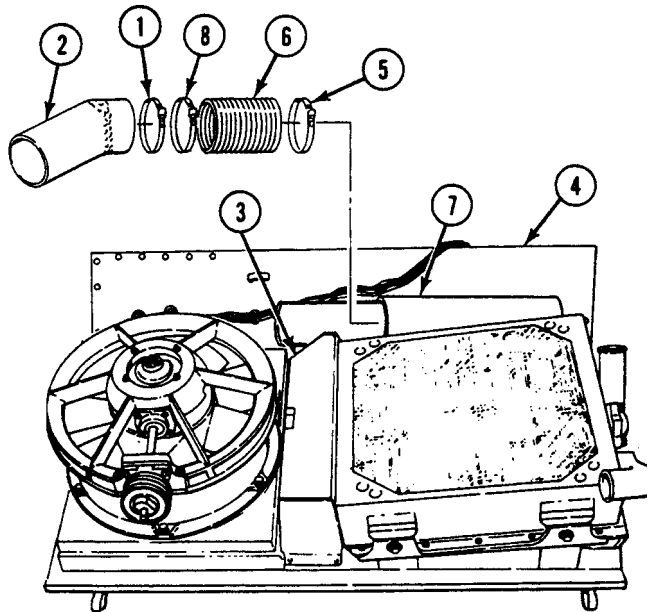
**FOLLOW-THROUGH STEPS**

1. Lower power plant grill (WP 0464 00).

END OF TASK

REPLACE EXHAUST EVACUATOR VALVE AND CONNECTOR

0175 00

THIS WORK PACKAGE COVERS:

Removal (page 0175 00-1).
 Installation (page 0175 00-2).

INITIAL SETUP:

Maintenance Level

Unit

References

See your -10

Tools and Special Tools

General mechanic's tool kit (WP 0926 00, Item 65)
 Torque wrench (WP 0926 00, Item 85)

Equipment Condition

Engine stopped (see your -10)
 Carrier blocked (see your -10)
 Trim vane lowered (see your -10)
 Power plant access door open (see your -10)
 Power plant grill raised (WP 0464 00)

Materials/Parts

Clamp (2)
 Lockwasher (2)

Personnel Required

Unit Mechanic

REMOVAL

1. Remove three screws (1) and washers (2) holding air cleaner support (3) to sponson.
2. Remove two screws (4), lockwashers (5), washers (6), and air cleaner support (7). Discard lockwashers.

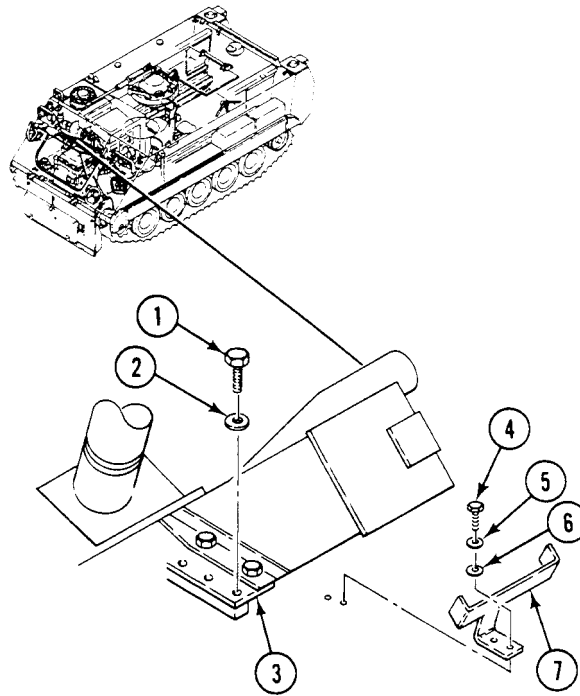

3. Loosen two clamps (8) securing hose (9) to evacuator valve (10) and air cleaner adapter (11). Slide hose (9) onto evacuator (10).
4. Remove two clamps (12) securing connector (13) to muffler (14) and evacuator valve (10). Discard clamps.

5. Move air cleaner against power plant. Remove connector (13) and valve (10) from muffler (14). Separate connector and valve. Remove clamps (8) and hose (9) from valve.

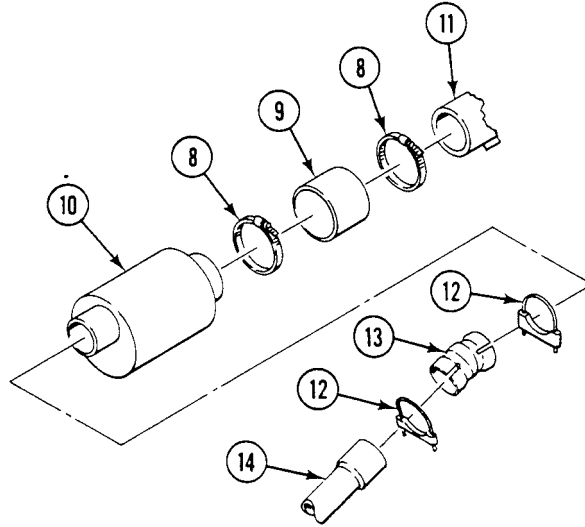

INSTALLATION

1. Join valve (1) and connector (2). Install hose (3) on valve (1). Install clamps (4) and valve (1).
2. Move air cleaner (5) against power plant. Install connector (2) and valve (1) on muffler (6).

NOTE

The position of the lettering may be within ± 1.5 inch (3.81 cm) of the top.

3. Rotate valve (1) and connector (2) until the lettering is on the top and the drain is on the bottom.
4. Secure connector (2) to muffler (6) and valve (1) with two new clamps (7).

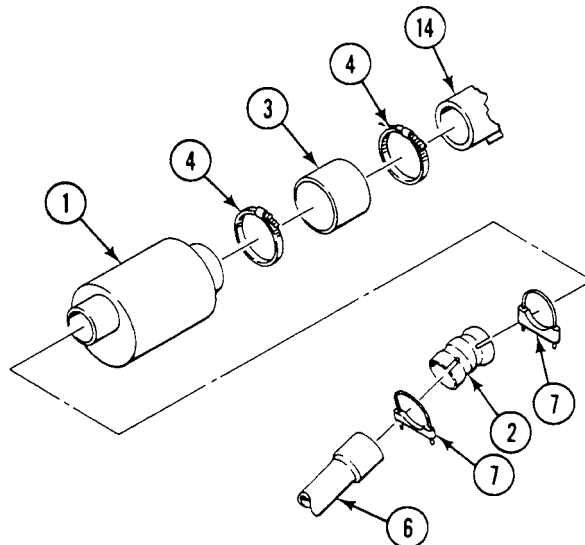

5. Move air cleaner (5) in position. Secure air cleaner to sponson with three screws (8) and washers (9). **TIGHTEN SCREWS TO 32-34 LB-FT (43-46 N·m) TORQUE. USE TORQUE WRENCH.**
6. Install support (10), two screws (11), new lockwashers (12), and flat washers (13).
7. Slide hose (3) on valve onto air cleaner adapter (14). Secure hose with two clamps (4).

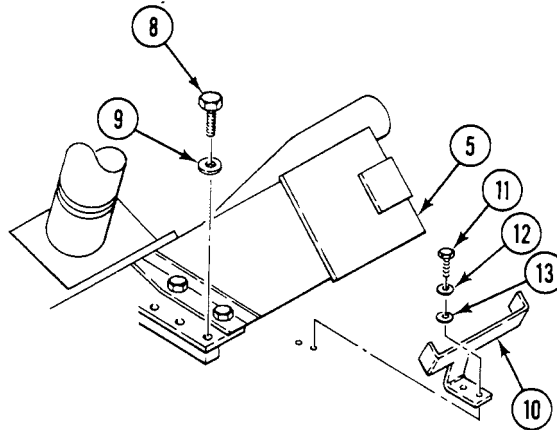
**FOLLOW-THROUGH STEPS**

1. Lower power plant grill (WP 0464 00).
2. Close power plant front access door (see your -10).
3. Raise trim vane (see your -10).

END OF TASK

CLEAN FUEL CAP VENT AND FILTER SCREEN

0176 00

THIS WORK PACKAGE COVERS:

Cleaning (page 0176 00-1).

INITIAL SETUP:

Maintenance Level

Unit

References

See your -10

Tools and Special Tools

General Mechanic's Tool Kit (WP 0926 00, Item 65)

Equipment Condition

Engine stopped (see your -10)

Carrier blocked (see your -10)

Materials/Parts

Cleaning cloth (WP 0928 00, Item 15)

Cleaning compound (WP 0928 00, Item 19)

Personnel Required

Unit Mechanic

CLEANING

WARNING



Fuel fumes can explode and burn you. Do not smoke or allow open flame near carrier when removing and cleaning fuel cap(s).

NOTE

**Carrier may have optional cap with pressure relief valve.
If fuel cap has pressure relief valve, do not perform this task.**

1. Open ballistic cover (1), and remove fuel cap (2) from filler neck (3).
2. Squeeze spring plate (4), and remove fuel cap (2), with attached chain (5), from filler neck (3).
3. Clean vent grommet (6) and screen cap (7) in fuel cap (2) as follows:
 - a. Using pliers, pull on the tang in the center of screen cap (7), and remove screen cap from fuel cap (2).

NOTE

Do not remove internal filter screen from screen cap.

- b. Check vent grommet (6) to make sure it is clean, free from damage, and secure.
- c. If vent grommet (6) is damaged, replace entire fuel cap (WP 0184 00 or WP 0185 00).

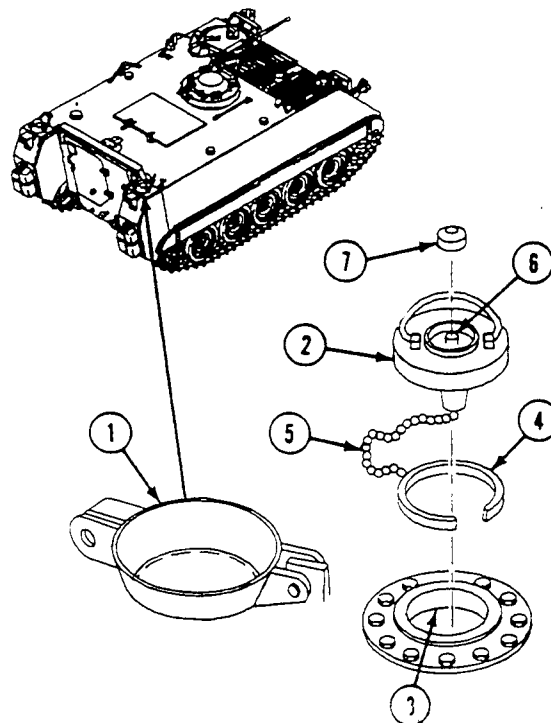

- d. If grommet (1) is clogged or dirty, remove and clean with cleaning compound and clean cloth.
- e. Reinstall grommet (1) in fuel cap (2). Make sure it is properly seated.

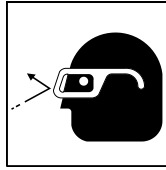
WARNING

Air pressure in excess of 30 psi (207 kPa) can injure personnel. Do not direct pressurized air at yourself or others. Always wear goggles.

- f. Clean screen cap (3) with cleaning compound. Dry with compressed air.
 - g. Reinstall screen cap (3) in fuel cap (2).
4. Squeeze spring plate (4), and install in filler neck (5).
 5. Install fuel cap (2), with attached chain (6) in filler neck (5).
 6. Close ballistic cover (7).

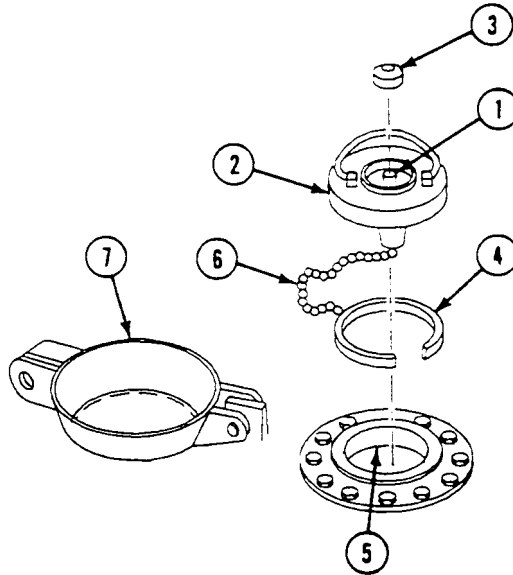

END OF TASK

DRAIN TANKS (ALL EXCEPT M577A3 AND M1068A3)

0177 00

THIS WORK PACKAGE COVERS:

Servicing (page 0177 00-1).

INITIAL SETUP:

Maintenance Level

Unit

References

See your -10

Tools and Special Tools

General Mechanic's Tool Kit (WP 0926 00, Item 65)

Equipment Condition

Materials/Parts

30 Gallon (114 liter) container (2)

Engine stopped (see your -10)

Carrier blocked (see your -10)

Personnel Required

Unit Mechanic

Battery ground strap disconnected (WP 0337 00) or
(WP 0339 00)

SERVICING

1. Open fuel filler combat cover (1). Remove fuel filler cap (see your -10).
2. Place a container (2), with at least 30 gallon (114 liters) capacity, directly beneath the fuel tank (3).

WARNING



Fuel flowing over a metal surface causes static electricity. This will cause a spark unless the surface is grounded.

3. Ground container (2) to carrier.
4. Shut off both fuel tank (3) shutoff valves. Drain fuel.
5. Install plug (4) in fuel tank (3) after the tank has been drained.

6. Install fuel filler cap. Close filler combat cover (1) to keep dirt out of tanks.

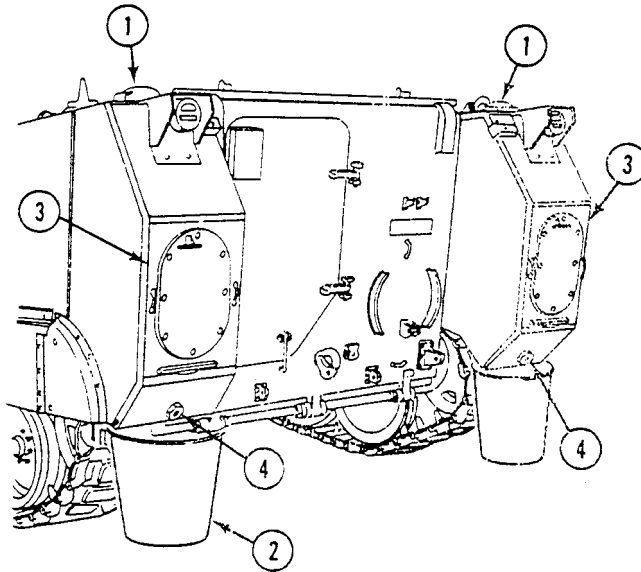
**FOLLOW-THROUGH STEPS**

1. Connect battery ground strap (WP 0337 00) or (WP 0339 00).
2. After maintenance has been performed, fill fuel tanks (see your -10).

END OF TASK

DRAIN FUEL TANKS (M577A3 AND M1068A3 ONLY)

0178 00

THIS WORK PACKAGE COVERS:

Drain (page 0178 00-1).

INITIAL SETUP:

Maintenance Level

Unit

References

See your -10

Tools and Special Tools

General Mechanic's Tool Kit (WP 0926 00, Item 65)
 Hose Assembly (WP 0926 00, Item 26)

Equipment Condition

Engine stopped (see your -10)
 Carrier blocked (see your -10)
 Battery ground lead disconnected (WP 0338 00).
 Rear compartment floor plates removed (WP 0539 00) or
 (WP 0544 00)

Materials/Parts

Sealing compound (WP 0928 00, Item 56)
 Wiping rag (WP 0928 00, Item 65)
 Suitable container

Personnel Required

Unit Mechanic

SERVICING

1. Open fuel filler combat cover (1) and remove filler cap.
2. Loosen drain plug retaining screw (2) from under carrier. Remove drain plug (3).
3. Place container (4) under hull drain opening.

WARNING

Fuel flowing over a metal surface causes static electricity. This will cause a spark unless the surface is grounded.

NOTE

Use wiping rag to wipe up any spilled fuel.

4. Attach a ground strap (5) between hull and container (4).

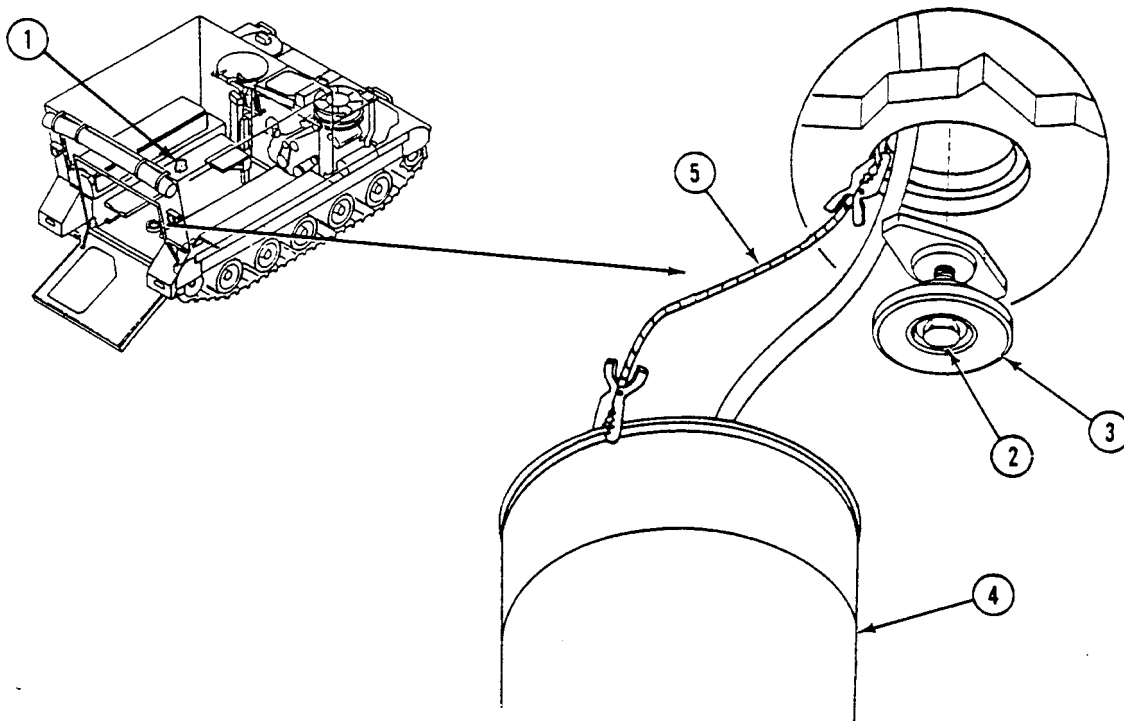

5. Remove pipe plug (1) from drain cock (2).
6. Install fuel drain hose (3) on drain cock (2). Insert drain hose through hull opening into container (4).
7. Open valve (5) and drain fuel from tanks.
8. Close valve (5) and remove hose (3) from drain cock (2).
9. Apply sealing compound to threads of pipe plug (1) and install plug in drain cock (2).
10. Remove ground strap (6) from hull and container (4).
11. Install drain plug (7) in hull and secure with retaining screw (8).
12. Install fuel filler cap. Close combat cover (9).

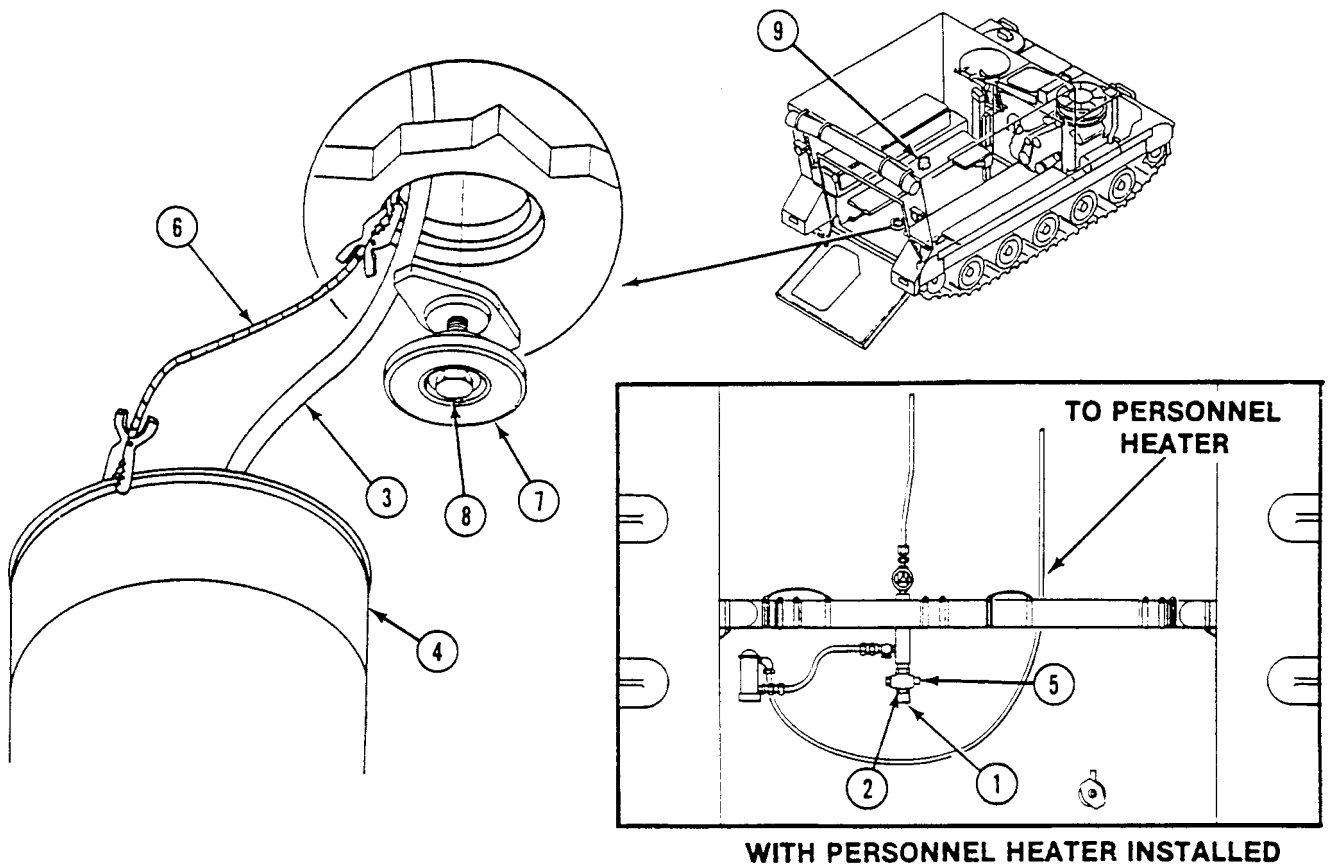

FOLLOW-THROUGH STEPS

1. Fill fuel tanks (see your -10).
2. Install rear compartment floor plates (WP 0539 00) or (WP 0544 00).
3. Connect battery ground lead (WP 0338 00).
4. Start engine (see your -10).
5. Raise and lock ramp (see your -10).
6. Stop engine (see your -10).

END OF TASK

REPLACE EXTERNAL FUEL TANKS (ALL EXCEPT M577A3 AND M1068A3)

0179 00

THIS WORK PACKAGE COVERS:

- Removal (page 0179 00-2).
 - Installation (page 0179 00-5).
-

INITIAL SETUP:

Maintenance Level

Unit

References

See your -10

Tools and Special Tools

- General Mechanic's Tool Kit (WP 0926 00, Item 65)
- Lifting Bracket (WP 0926 00, Item 9)
- Socket Wrench Set (WP 0926 00, Item 73)
- Torque Wrench (WP 0926 00, Item 86)
- Suitable Lifting Device

Equipment Condition

- Engine stopped (see your -10)
- Carrier blocked (see your -10)
- Ramp lowered (see your -10)
- Battery ground strap disconnected (WP 0337 00)
- Fuel tanks drained (WP 0177 00)
- Filler covers and locks removed (WP 0182 00)
- Filler caps and strainers removed (WP 0184 00)
- Fuel tank access covers removed (WP 0187 00)
- Cable reel holders removed (M1064A3)
(WP 0603 00)
- Tail lights and guards removed (WP 0298 00)
- Fuel quantity transmitter removed (WP 0190 00)
- Track shrouds removed (WP 0438 00)

Materials/Parts

- Adhesive (WP 0928 00, Item 4)
- Caulking compound (WP 0928 00, Item 14)
- Grease GMD (WP 0928 00, Item 41)
- Sealing compound (WP 0928 00, Item 54)
- Sealing compound (WP 0928 00, Item 56)
- Sealing compound primer (WP 0928 00, Item 57)

Gasket

Lockwasher (5)

Setscrew (4)

Personnel Required

Unit Mechanic

Helper (H)

REMOVAL

NOTE

Two pipes are removed from both fuel tanks in the same way.

1. Unthread pipe (1) from fuel tank (2).

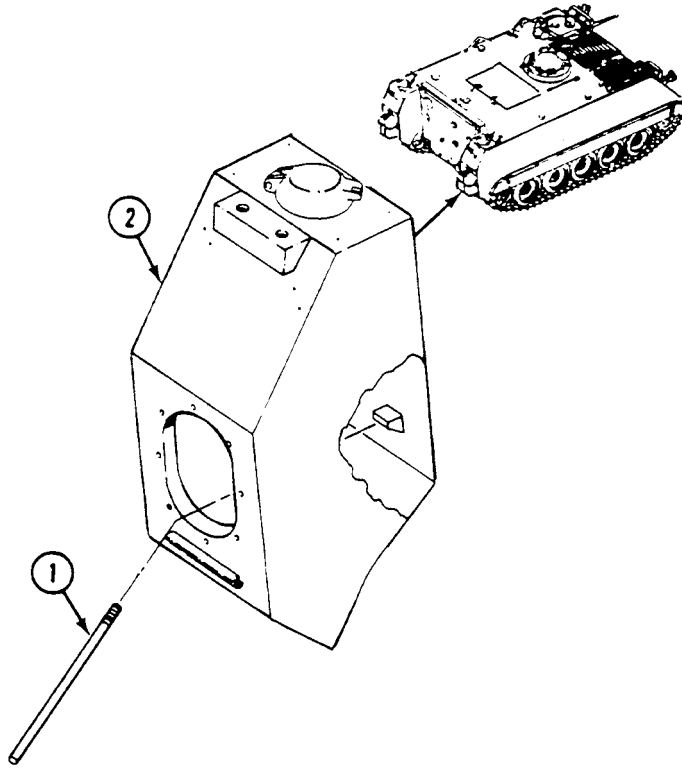

2. On M113A3 only, slide spall liners to access fuel fittings (see your -10).

NOTE

Fuel hoses are removed from both fuel tanks in the same way. Right side fuel tank shown.

3. On M113A3 only, remove five screws (1), lockwashers (2), washers (3), and guard (4) from bulkhead. Discard lockwashers.
4. Remove two elbows (5) with fuel hoses from two adapters (6).
5. Remove two adapters (6) from fuel tank (7).

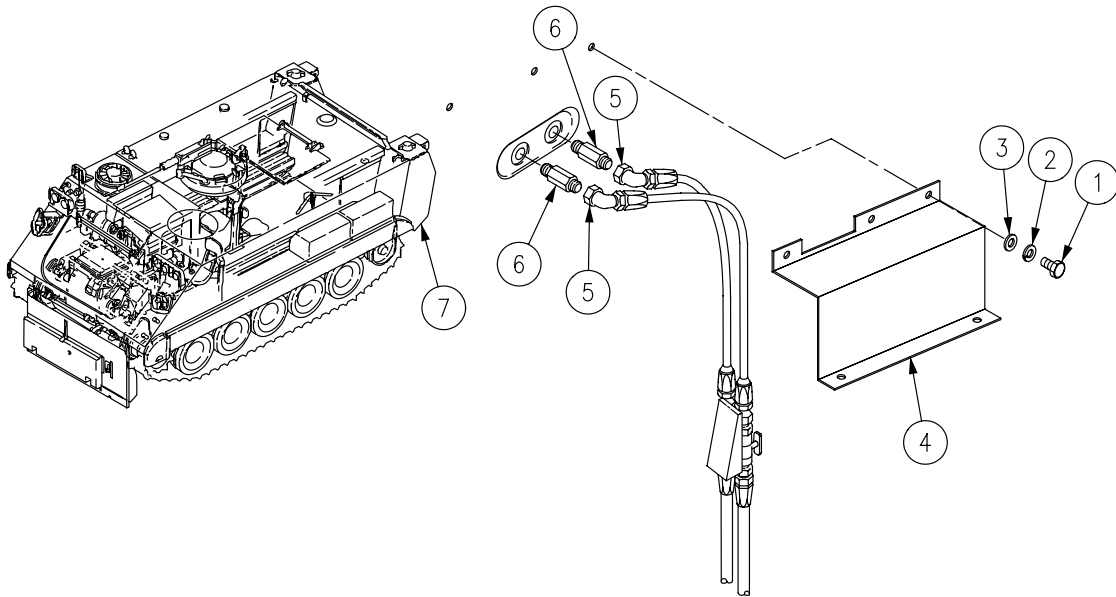

NOTE

Both fuel tanks are removed from carrier in the same way. Left side fuel tank shown.

Use tail light bracket screws to secure lifting bracket to fuel tank.

6. Install lifting bracket (8) on tail light bracket mounting holes (9). Secure with two screws (10). Attach lifting device to lifting bracket.

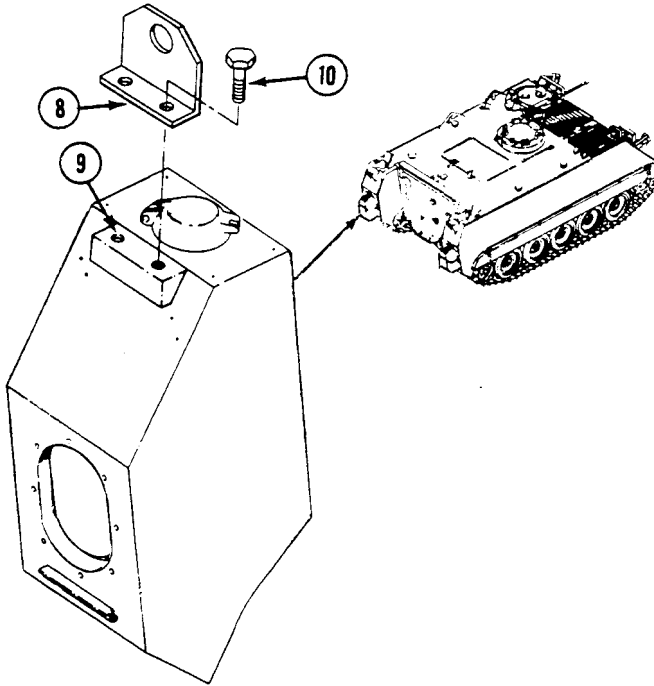

7. Remove fuel cap locking thumbscrew (11) from inside carrier.

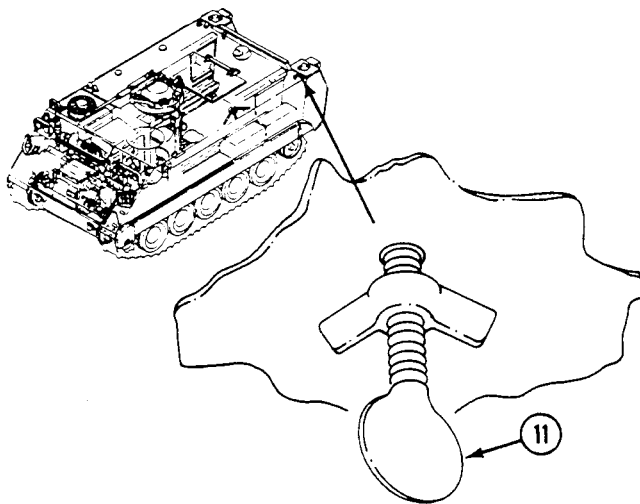

WARNING



Damaged lifting slings can fail with load. Soldiers can be killed or injured. Inspect all slings (WP 0673 00) before use. Do not use damaged slings.

WARNING



Hanging loads can kill or injure you. Keep away from hanging loads and overhead equipment. Keep hands out of compartment while power plant is being lifted for removal or lowered for installation.

8. Remove five screws (1), washers (2), and fuel tank (3) from carrier. Remove gasket (4) from fuel tank. Discard gasket.

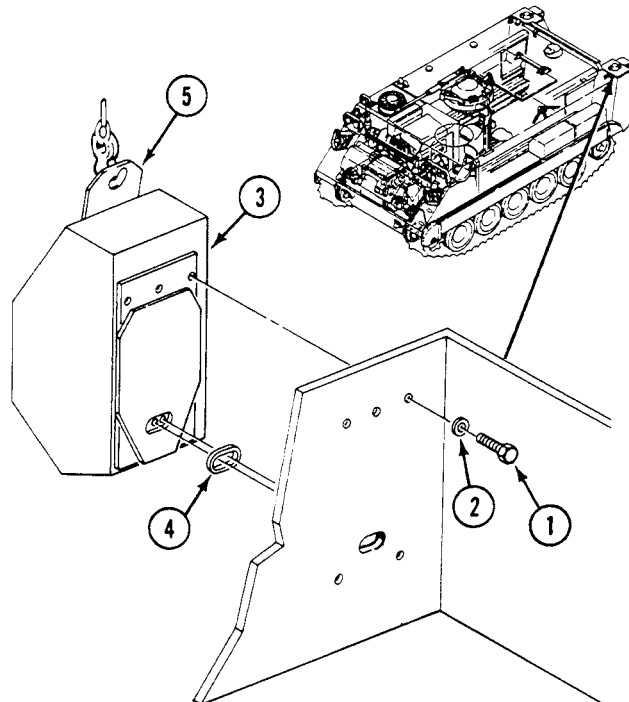

INSTALLATION

NOTE

Both fuel tanks are installed on carrier in the same way. Left side fuel tank shown.

1. Apply thin coat of adhesive to gasket surface of fuel tank (3) and new gasket (4). When adhesive has become tacky, install gasket on tank.

WARNING



Damaged lifting slings can fail with load. Soldiers can be killed or injured. Inspect all slings (WP 0673 00) before use. Do not use damaged slings.

WARNING



Hanging loads can kill or injure you. Keep away from hanging loads and overhead equipment. Keep hands out of compartment while power plant is being lifted for removal or lowered for installation.

2. Attach lifting device to lifting bracket (5). Position fuel tank (3) against rear hull plate. Have helper assist.
3. Apply grease GMD to threads of five screws (1).

NOTE

Inside of mounting holes and full diameter area under each washer must be free of paint to ensure good electrical ground.

4. Check that mounting holes and surfaces are free of paint. Secure fuel tank (3) to rear hull plate with five screws (1) and washers (2). TIGHTEN SCREWS TO 270-295 LB-FT (366-400 N·m) TORQUE. Remove lifting device. Have helper assist.
5. Apply caulking compound to space around installed screw heads (1) and washers (2) on rear hull plate. Do not apply compound to screw threads which engage with fuel tank (3).

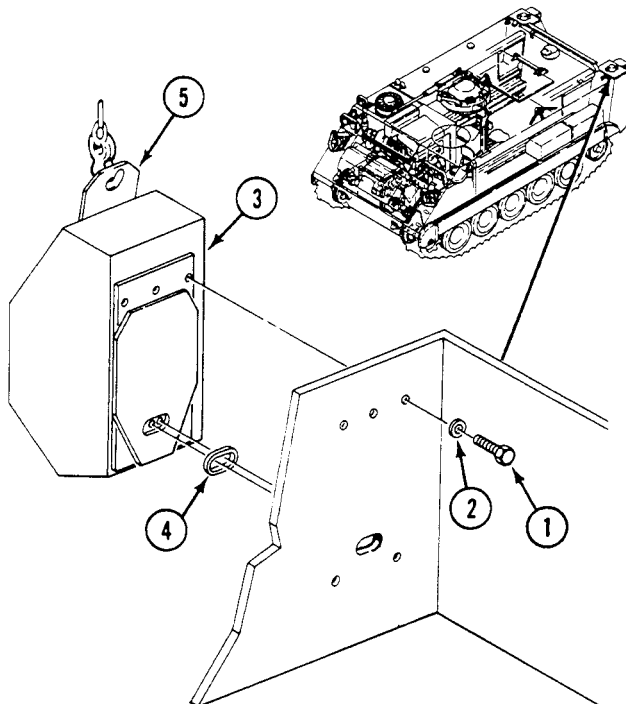

6. Install fuel cap locking thumbscrew (6) in carrier bulkhead.

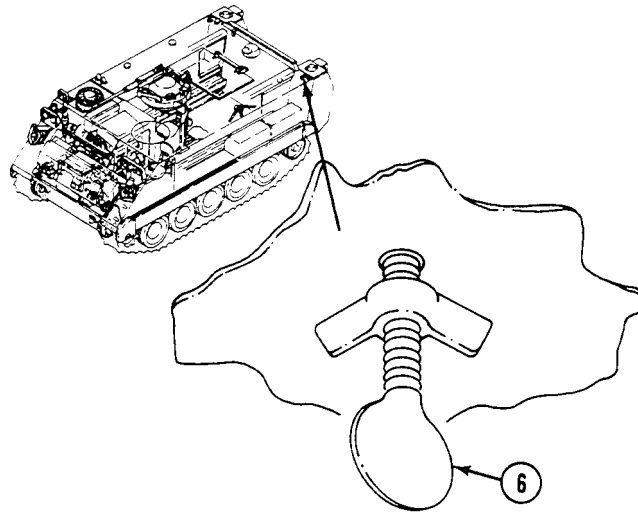

NOTE

Save lifting bracket screws for installation of tail light bracket.

7. Remove two screws (1) and lifting bracket (2) from fuel tank (3).

NOTE

Two pipes are installed in both fuel tanks in the same way.

8. Apply sealing compound primer to threads of pipe (4). Then coat threads with sealing compound.
9. Install pipe (4) in fuel tank (3).

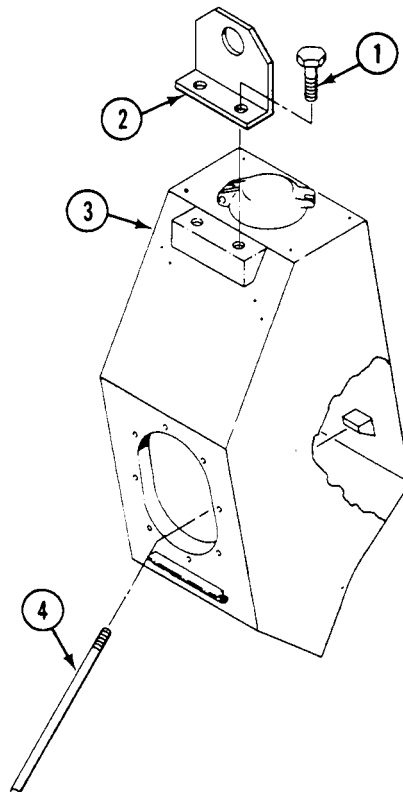

NOTE

Fuel hoses are installed on both fuel tanks the same way. Right side fuel tank shown.

10. Apply sealing compound to threads of adapters (5). Install adapters in fuel tank.
11. Apply caulking compound to space around adapters on fuel tank (6).
12. Install two elbows (7) with hoses on adapters (5).
13. On M113A3 only, install guard (8) on bulkhead. Secure with five screws (9), new lockwashers (10), and washers (11).

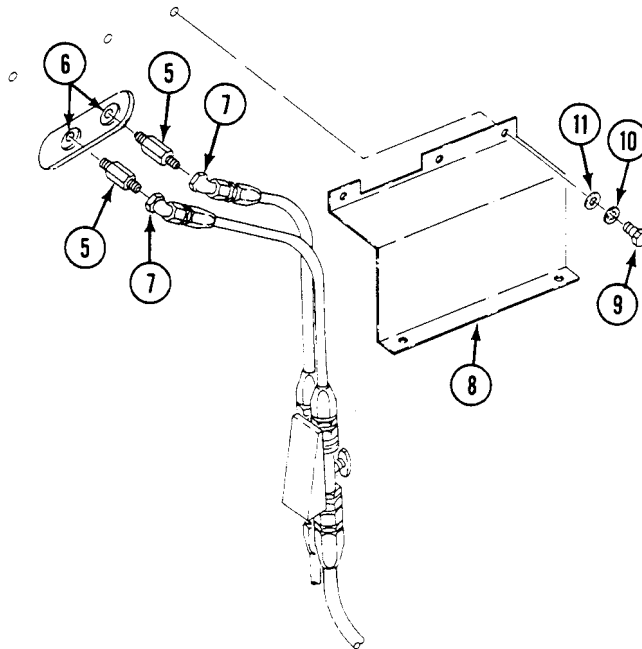
**NOTE**

The four spare electrical mounting holes are always the holes located on the outer edge of each fuel tank. The electrical guards are always mounted on the inner edge of each fuel tank.

14. Install four setscrews (12) in spare holes provided for electrical mounting.

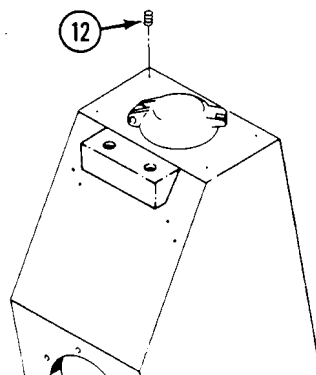

FOLLOW-THROUGH STEPS

1. Install track shrouds (WP 0438 00).
2. Install fuel quantity transmitter (WP 0190 00).
3. Install guards and tail lights (WP 0298 00).
4. Install cable reel holders (M1064A3) (WP 0603 00).
5. Install fuel tank access covers (WP 0187 00).
6. Install filler caps and strainers (WP 0184 00).
7. Install filler covers and locks (WP 0182 00).
8. Fill fuel tanks (see your -10).
9. Connect battery ground strap (WP 0337 00).
10. Start engine (see your -10). Check for leaks.
11. Raise and lock ramp (see your -10).
12. Stop engine (see your -10).
13. Close spill liners (M113A3) (see your -10).

END OF TASK

REPLACE FUEL TANKS (M577A3 AND M1068A3 ONLY)

0180 00

THIS WORK PACKAGE COVERS:

Removal (page 0180 00-1).
 Installation (page 0180 00-4).

INITIAL SETUP:

Maintenance Level

Unit

Tools and Special Tools

General Mechanic's Tool Kit (WP 0926 00, Item 65)

Materials/Parts

Sealing compound (WP 0928 00, Item 56)

Key washers (6)

Locknut (4)

Personnel Required

Unit Mechanic

References

See your -10

Equipment Condition

Engine stopped (see your -10)

Carrier blocked (see your -10)

Ramp lowered (see your -10)

Battery ground lead disconnected (WP 0338 00)

Map board removed (see your -10)

Work tables removed (WP 0578 00) or (WP 0581 00)
 and (WP 0582 00)

Fuel tanks drained (WP 0178 00)

Rear bilge pump discharge tube removed (WP 0634 00)

Fuel quantity transmitter removed (WP 0191 00)

Fuel tank access cover removed (WP 0188 00)

Fuel tank filler flange removed (WP 0189 00)

REMOVAL

1. Disconnect four supply hoses (1) and four adapters (2) from fuel tanks (3) and (4).
2. Loosen two clamps (5) and remove two supply hoses (6) from fuel tanks (3) and (4).
3. Disconnect vent hose (7) from elbow (8).
4. Disconnect vent hose (9) from elbow (10).

5. Remove six screws (11), key washers (12), two plates (13), and two brackets (14) that secure front of fuel tanks (3) and (4) on sponson. Discard key washers.

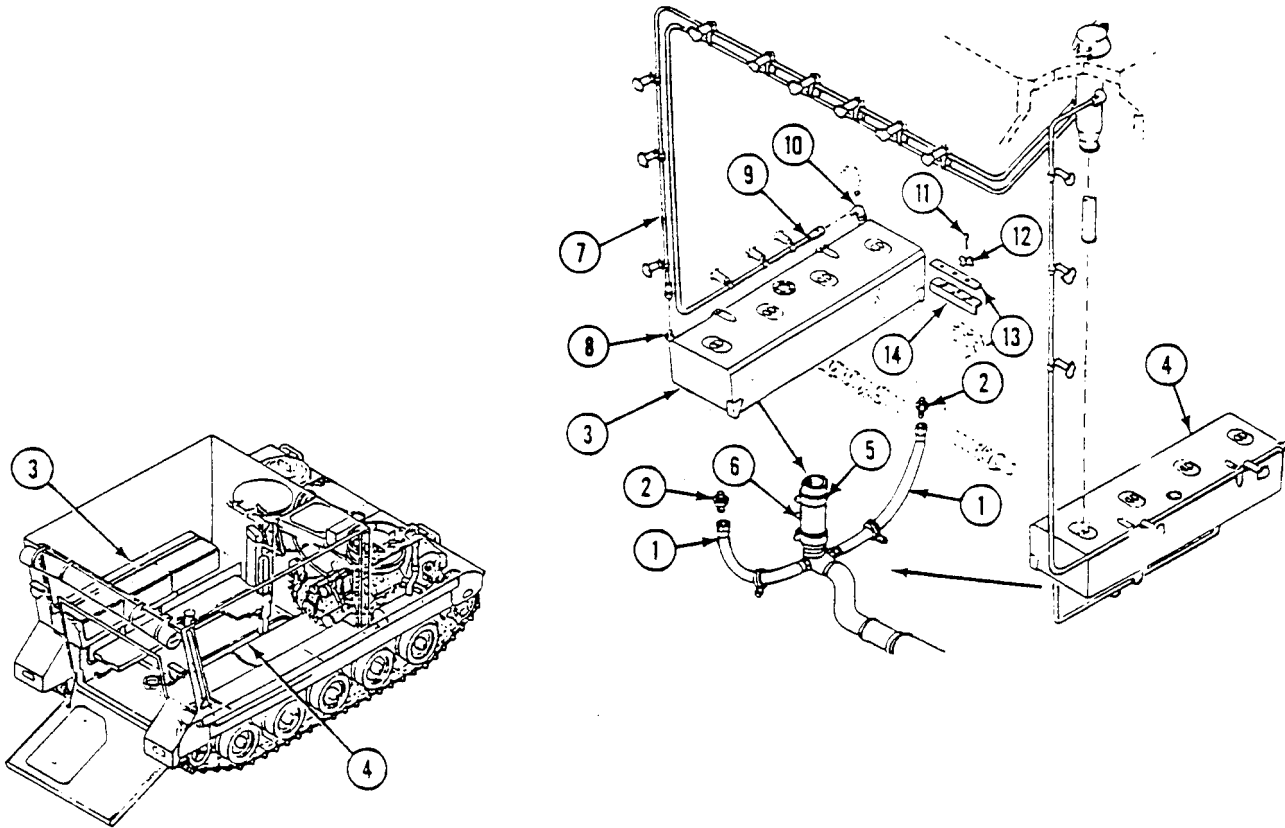

REPLACE FUEL TANKS (M577A3 AND M1068A3 ONLY) — Continued

0180 00

6. Remove four locknuts (1), screws (2), 12 washers (3), and 4 mounts (4) that secure bottom of fuel tanks (5) and (6) to sponson. Discard locknuts.
7. Disconnect vent tube (7) from elbow (8).
8. Remove four screws (9), plates (10), eight washers (11), and four mounts (12) that secure bottom of fuel tanks (5) and (6) to sponson.
9. Remove two fuel tanks (5) and (6) from carrier.
10. Remove elbow (13) from left fuel tank (5).
11. Remove elbow (14) from nipple (15).
12. Remove nipple (15) and elbow (16) from left fuel tank (5).
13. Remove elbow (8) and bushing (17) from right fuel tank (6).
14. Remove plug (18) from right fuel tank (6).

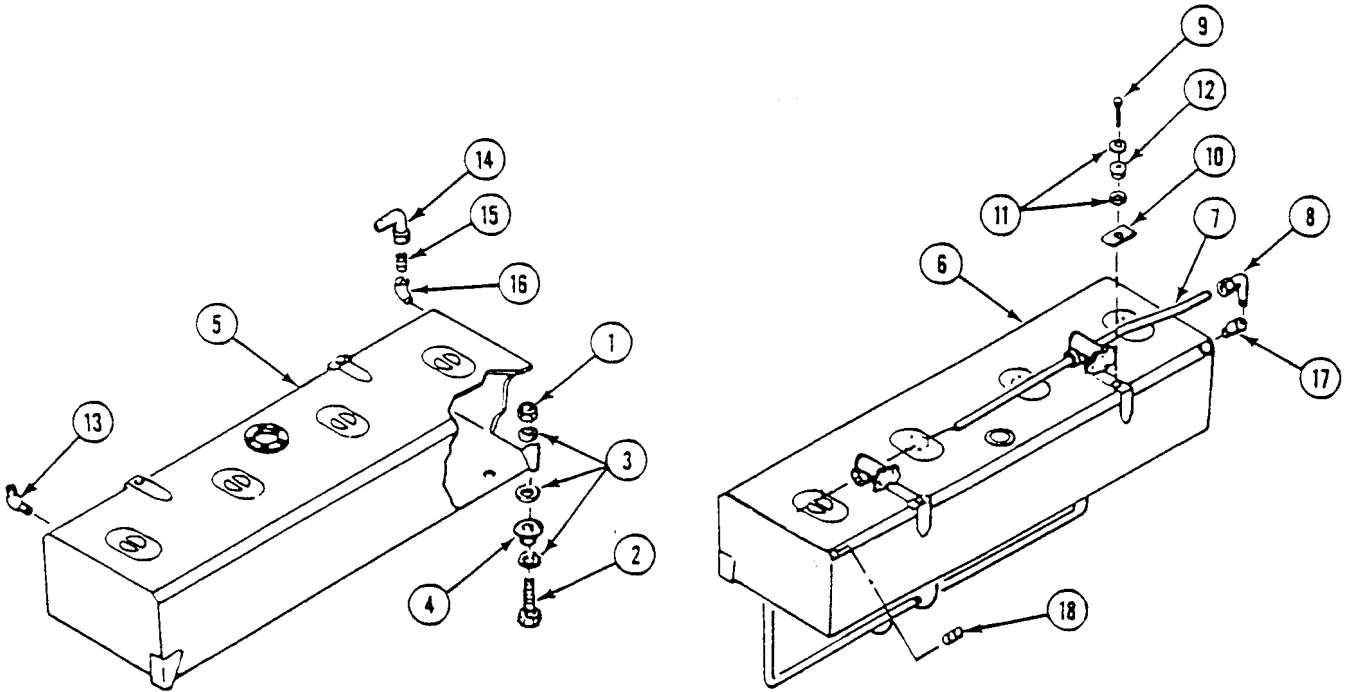

INSTALLATION

1. Apply a thin, even coat of sealing compound to cleaned external threads of fittings.
2. Install plug (18) in right fuel tank (6).
3. Install bushing (17) in fuel tank (6).
4. Install elbow (8) in bushing (17).
5. Install elbow (13) in left fuel tank (5).
6. Install elbow (16) in left fuel tank (5).
7. Install nipple (15) in elbow (16).
8. Install elbow (14) on nipple (15).
9. Place fuel tanks (5) and (6) on left and right sponsons.
10. Secure top of two fuel tanks (5) and (6) to hull with four screws (9), plates (10), eight washers (11), and four mounts (12).
11. Secure bottom of two fuel tanks (5) and (6) to sponson with four mounts (4), new locknuts (1), screws (2), and 12 washers (3).

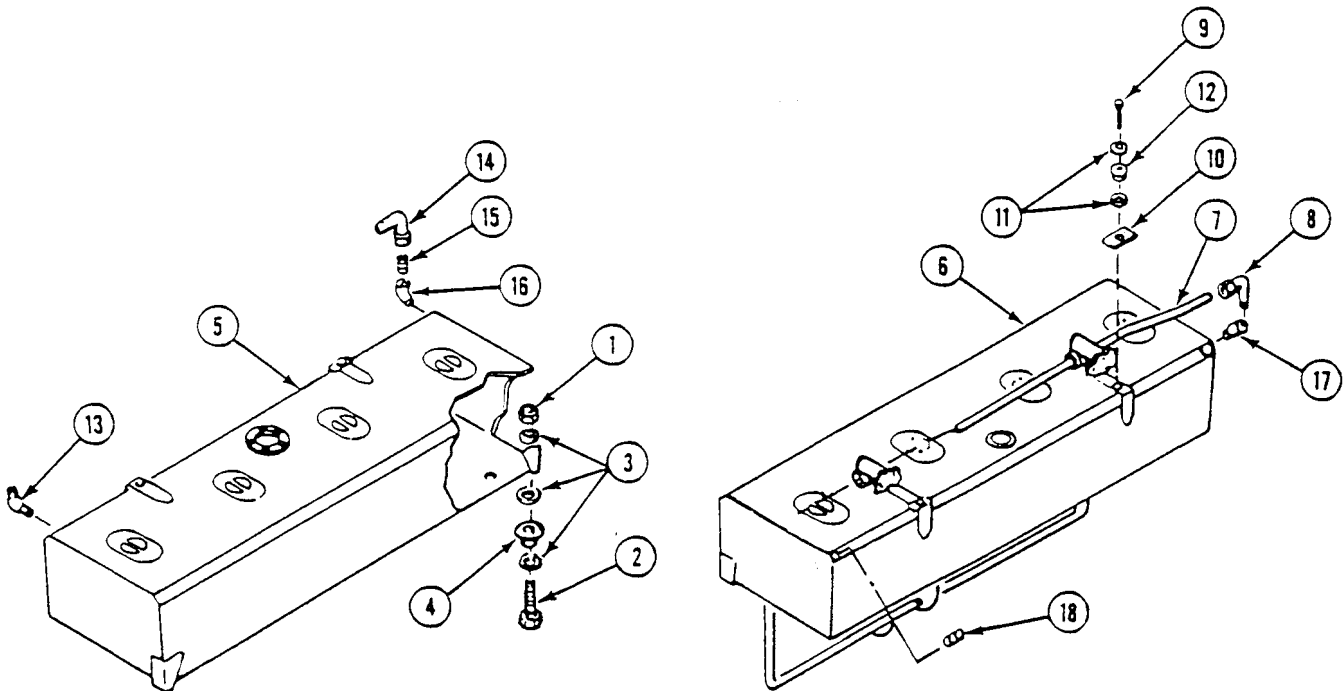

12. Secure front of two fuel tanks (3) and (4) to sponson with six screws (11), new key washers (12), two plates (13), and bracket (14).
13. Connect vent hose (9) to elbow (10).
14. Connect vent hose (7) to elbow (8).
15. Install two supply hoses (6) on fuel tanks (3) and (4). Secure with two clamps (5).

16. Connect four supply hoses (1) with four adapters (2) on fuel tanks (3) and (4).

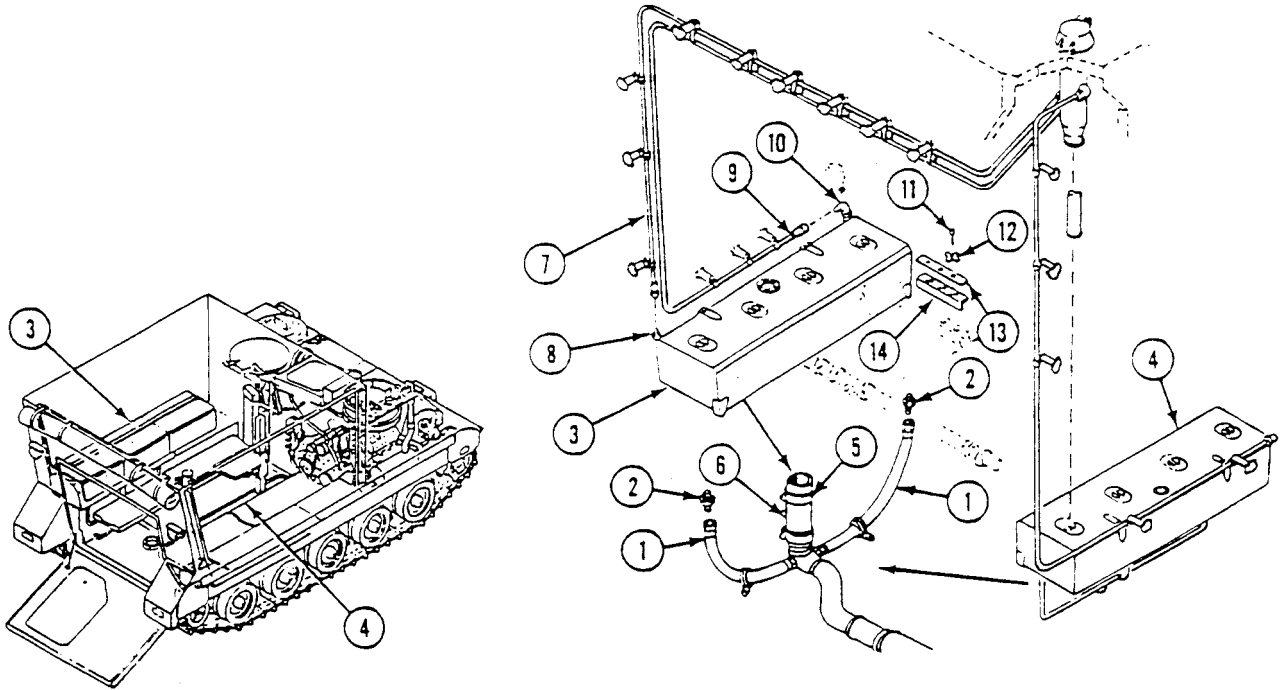

FOLLOW-THROUGH STEPS

1. Install fuel tank filler flange (WP 0189 00).
2. Install fuel tank access covers (WP 0188 00).
3. Install fuel quantity transmitter (WP 0191 00).
4. Install rear bilge pump discharge tube (WP 0634 00).
5. Fill fuel tanks (see your -10). Check for leaks.
6. Connect battery ground lead (WP 0338 00).
7. Start engine (see your -10). Check for leaks.
8. Raise and lock ramp (see your -10).
9. Stop engine (see your -10).
10. Install work tables (WP 0578 00) or (WP 0581 00) and (WP 0582 00).
11. Install map board (see your -10).

END OF TASK

TEMPORARY FUEL TANK REPAIR (M577A3 AND M1068A3 ONLY)

0181 00

THIS WORK PACKAGE COVERS:

Repair (page 0181 00-1).

INITIAL SETUP:

Maintenance Level

Unit

References

See your -10

Tools and Special Tools

General Mechanic's Tool Kit (WP 0926 00, Item 65)

Equipment Condition

Materials/Parts

Cleaning compound (WP 0928 00, Item 19)
 Rubber adhesive tape (WP 0928 00, Item 46)
 Sealing compound (WP 0928 00, Item 56)

Engine stopped (see your -10)
 Carrier blocked (see your -10)
 Ramp lowered (see your -10)
 Battery ground lead disconnected (WP 0338 00)
 Fuel tank removed (optional), (WP 0180 00) or
 Fuel drained below area of repair (WP 0178 00)

Personnel Required

Unit Mechanic

REPAIR OR REPLACEMENT

CAUTION

Be sure fuel level in tank is below area to be repaired.

NOTE

This task is for fuel tank temporary repair only. Repair is not feasible in temperatures below +40°F (+4°C). Best results are obtained if temperature is between 75° and 90°F (24° and 32°C).

1. Clean 3 to 4 inches (8 to 10 cm) around repair area. Use a wire brush, steel wool, or emery cloth.
2. Clean area with cleaning compound. Dry area with a clean cloth.
3. Reinforce small repair area with clean cloth or rubber adhesive tape.
4. Reinforce large repair area with sheet metal (aluminum), cut to fit.

NOTE

Sealing compound is usable for two hours after mixing. Use mixed sealing compound within this time.

5. Apply mixed sealing compound 3/16-1/4 inch (4-6 mm) thick over repair area.
6. Apply 1/16 inch (2 mm) minimum of sealing compound over reinforcement. Sealing compound must extend at least two inches (5 cm) beyond reinforcement on all sides.
7. Allow sealing compound to cure before filling fuel tank. Sealing compound will be tack-free in 40 hours and cured in 72 hours.

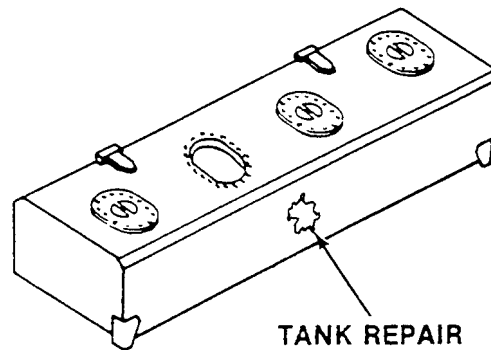
**FOLLOW-THROUGH STEPS**

1. Install fuel tank (WP 0180 00), (optional).
2. Fill fuel tank (see your -10). Check tank for leaks.
3. Connect battery ground lead (WP 0338 00).
4. Start engine (see your -10).
5. Raise and lock ramp (see your -10).
6. Stop engine (see your -10).

END OF TASK

REPLACE FUEL TANK FILLER COVER AND LOCK (ALL EXCEPT M577A3 AND M1068A3)

0182 00

THIS WORK PACKAGE COVERS:

Removal (page 0182 00-1).
 Installation (page 0182 00-2).

INITIAL SETUP:

Maintenance Level

Unit

References

TM 9-2350-277-10

Tools and Special Tools

General Mechanic's Tool Kit (WP 0926 00, Item 65)

Equipment Condition

Engine stopped (see your -10)

Carrier blocked (see your -10)

Battery ground strap disconnected (WP 0337 00) or (WP 0339 00)

Materials/Parts

Spring pin (3)

Personnel Required

Unit Mechanic

Ramp lowered (see your-10)

REMOVAL

1. Loosen wing nut (7) and thumbscrew (6) from inside carrier.
2. Remove spring pin (1), pin (2), washer (4), and spring (5) from support (3). Discard spring pin.

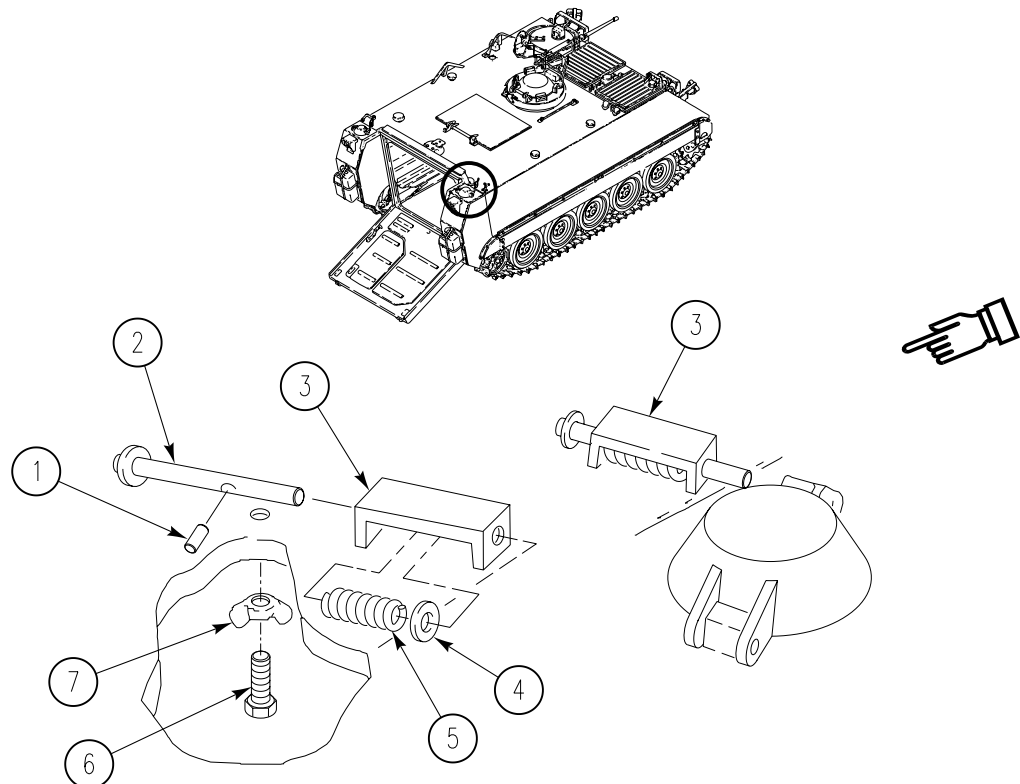

REPLACE FUEL TANK FILLER COVER AND LOCK (ALL EXCEPT M577A3 AND M1068A3) — Continued

0182 00

3. Remove spring pin (8), washer (9), pin (10), and spring (11) from cover (12). Discard spring pin.
4. Remove spring pin (13) and cover (12) from top of hull. Discard spring pin.

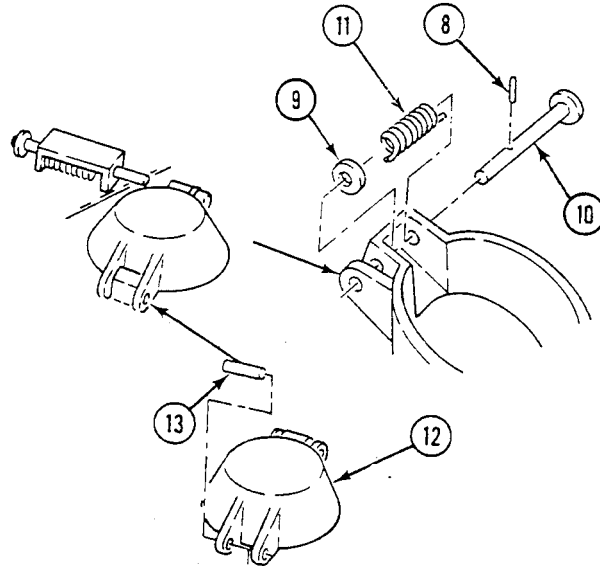

INSTALLATION

1. Secure spring (1), pin (2), and washer (3) to cover (4) with new spring pin (5).
2. Secure spring (6), washer (7), and pin (8) to support (9) with new spring pin (10).
3. Secure cover (4) to hull with new spring pin (11).
4. Turn thumbscrew (12) into lock position. Secure with wing nut (13).

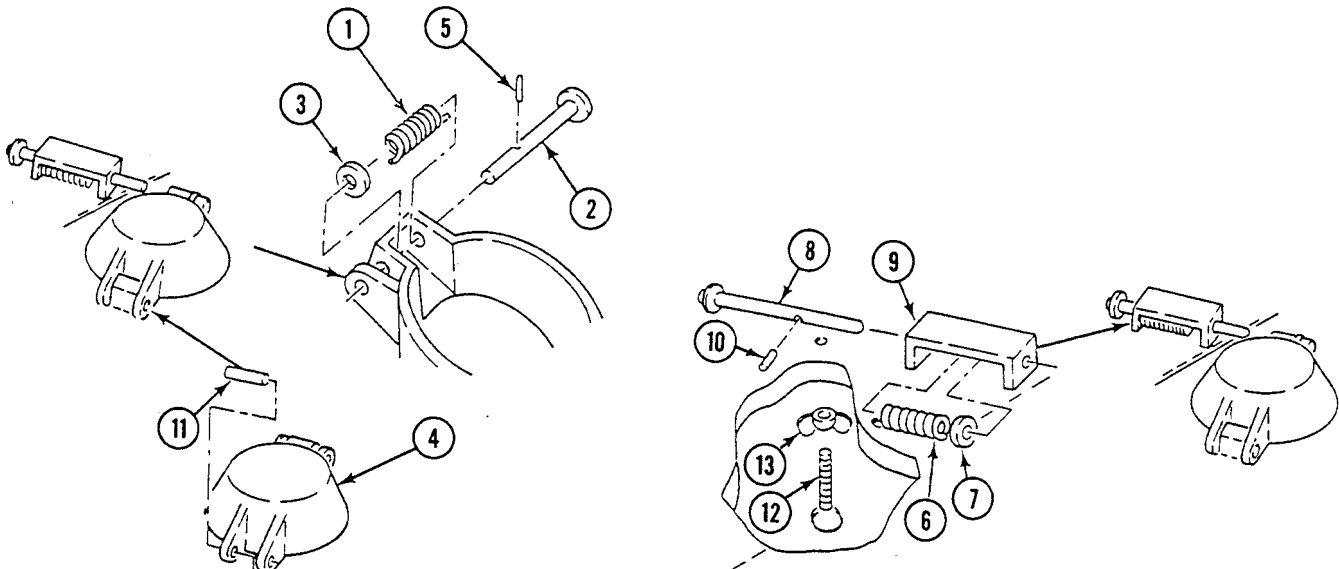

**REPLACE FUEL TANK FILLER COVER AND LOCK (ALL EXCEPT M577A3 AND
M1068A3) — Continued**

0182 00

FOLLOW-THROUGH STEPS

1. Connect battery ground strap (WP 0337 00) or (WP 0339 00).

END OF TASK

REPLACE FUEL TANK FILLER COVER AND LOCK (M577A3 AND M1068A3 ONLY)

0183 00

THIS WORK PACKAGE COVERS:

Removal (page 0183 00-1).
 Installation (page 0183 00-2).

INITIAL SETUP:

Maintenance Level

Unit

References

See your -10

Tools and Special Tools

General Mechanic's Tool Kit (WP 0926 00, Item 65)

Materials/Parts

Spring pin
 Spring pin

Equipment Condition

Engine stopped (see your -10)

Personnel Required

Unit Mechanic

Carrier blocked (see your -10)

Ramp lowered (see your -10)

REMOVAL

NOTE

If threads on thumbscrew were previously deformed, do Step 1.

1. Grind away deformed threads on thumbscrew (1). Remove wing nut (2) and thumbscrew (1).
2. Loosen wing nut (2) and thumbscrew (1) above fuel tank inside carrier.
3. Remove spring pin (3) and cover (4) from top of hull. Discard spring pin.

REPLACE FUEL TANK FILLER COVER AND LOCK (M577A3 AND M1068A3 ONLY) —
Continued

0183 00

4. Remove spring pin (5), washer (6), pin (7), and spring (8) from cover (4). Discard spring pin.

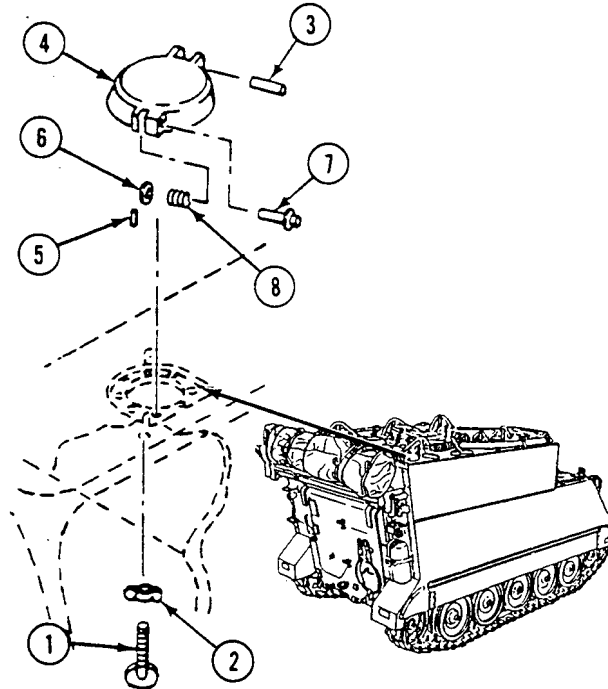
**INSTALLATION****NOTE**

If thumbscrew and wing nut were removed, do Step 1.

1. Screw wing nut (2) on thumbscrew (1) and install thumbscrew inside carrier above fuel tank. Deform threads on thumbscrew (1). Tighten wing nut (2).
2. Secure spring (8), pin (7), and washer (6) to cover (4) with new spring pin (5).
3. Secure cover (4) to hull with new spring pin (3).
4. Turn thumbscrew (1) into lock position. Tighten wing nut (2).

FOLLOW-THROUGH STEPS

1. Start engine (see your -10).
2. Raise and lock ramp (see your -10).
3. Stop engine (see your -10).

END OF TASK

REPLACE FILLER CAP AND STRAINER PARTS (ALL EXCEPT M577A3 AND M1068A3)

0184 00

THIS WORK PACKAGE COVERS:

- Removal (page 0184 00-2)
 - Installation (page 0184 00-3)
-

INITIAL SETUP:

Maintenance Level

Unit

References

TM 9-2350-277-10

Tools and Special Tools

General Mechanic's Tool Kit (WP 0926 00, Item 65)

Equipment Condition

Materials/Parts

Lockwire (WP 0928 00, Item 42)

Gasket

Engine stopped (see your —10)

Carrier blocked (see your —10)

Personnel Required

Unit Mechanic

Battery ground strap disconnected (WP 0339 00) or (WP 0337 00)

— Continued

REMOVAL

NOTE

Carrier may have optional cap with pressure relief valve.

If fuel cap has pressure relief valve, cap is removed by lifting pressure relief valve handle, then turning cap counterclockwise.

1. Unfasten fuel filler cap and chain assembly (1) from filler neck (2).
2. Remove lockwire (3), 12 screws (4), filler neck (2), strainer (5), and filler cap and chain assembly (1) from hull top. Discard lockwire.
3. Pull filler cap and chain assembly (1) through opening in filler neck (2).
4. Remove gasket (6). Discard gasket.

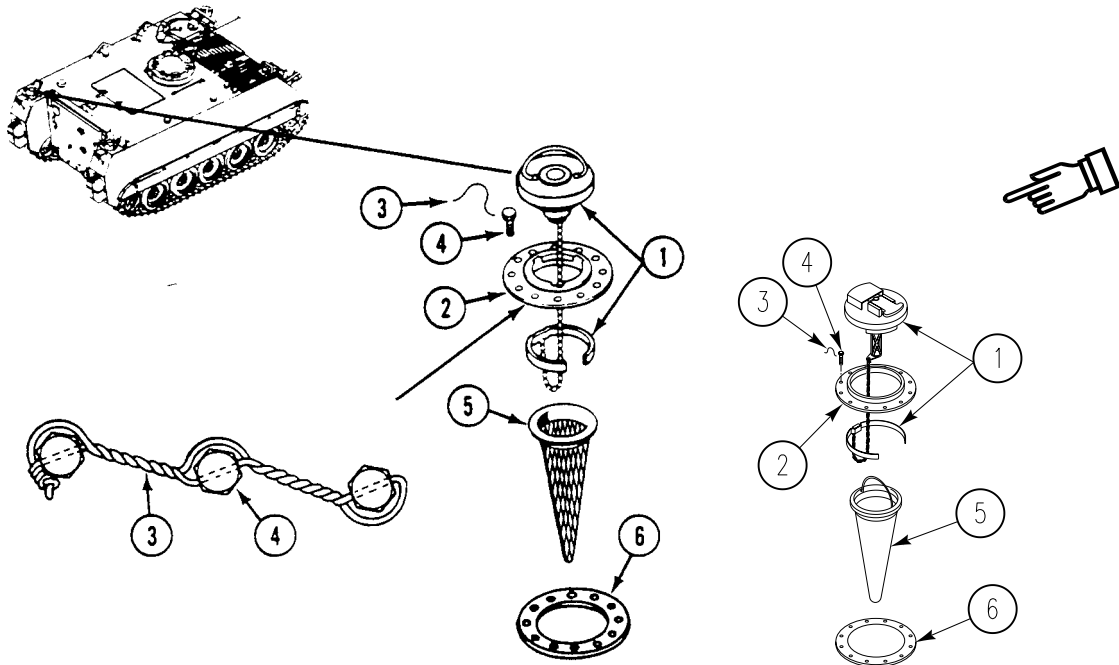

— Continued

INSTALLATION

1. Install new gasket (6).
2. Install filler cap and chain assembly (1) through filler neck (2).
3. Secure filler neck (2), strainer (5), and filler cap and chain assembly (1) to hull top with 12 screws (4).
4. Install new lockwire (3) thru heads of 12 screws (4). Secure with double twist method.
5. Fasten filler cap and chain assembly (1) in filler neck (2).

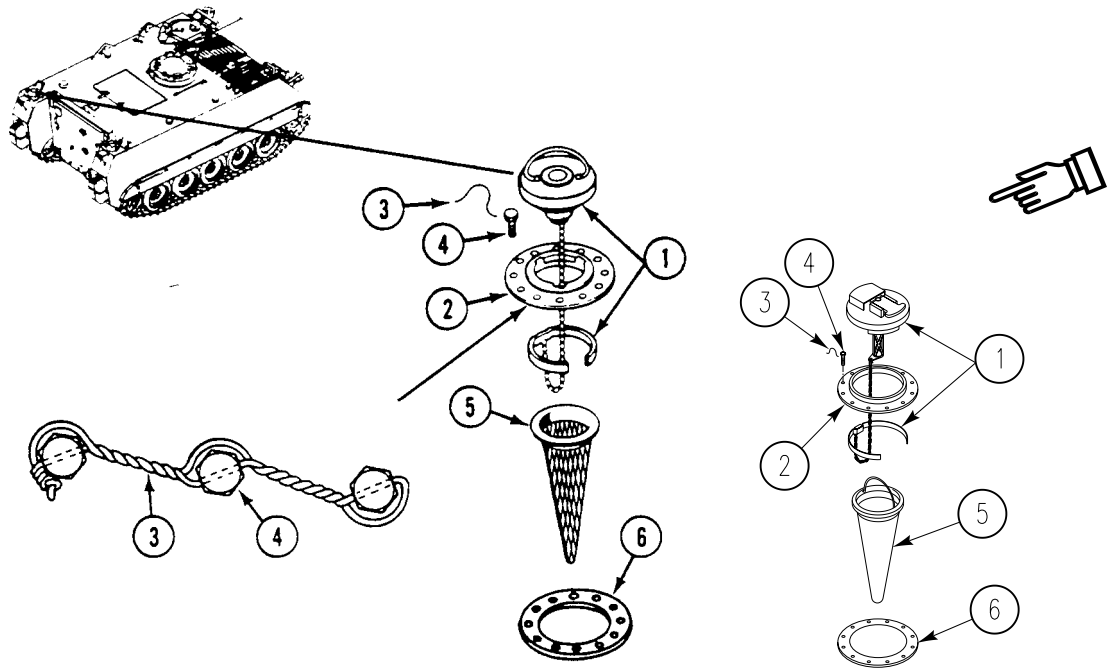

FOLLOW-THROUGH STEPS

1. Connect battery ground strap (WP 0339 00) or (WP 0337 00).

END OF TASK

REPLACE FILLER CAP AND STRAINER PARTS (M577A3 AND M1068A3 ONLY)

0185 00

THIS WORK PACKAGE COVERS:

Removal (page 0185 00-1).
Installation (page 0185 00-2).

INITIAL SETUP:

Maintenance Level

Unit

References

TM 9-2350-277-10

Tools and Special Tools

General Mechanic's Tool Kit (WP 0926 00, Item 65)

Equipment Condition

Engine stopped (see your -10)

Materials/Parts

Nonelectrical wire (WP 0928 00, Item 42)

Carrier blocked (see your -10)

Personnel Required

Unit Mechanic

Battery ground lead disconnected (WP 0338 00)

Combat filler cover and lock open (see your -10)

REMOVAL

NOTE

Carrier may have optional cap with pressure relief valve.

If fuel cap has pressure relief valve, remove cap by lifting pressure relief handle and turning cap counterclockwise.

1. Unfasten fuel filler cap and chain assembly (1) from filler neck.
2. Compress C ring (3) and remove from filler neck (2).
3. Remove lockwire (4), twelve screws (5), filler neck (2), retainer (7), and filler cap and chain assembly (1) from hull top. Discard lockwire.
4. Loosen clamp (8) that secures boot (9) to inside fuel tank. Remove boot through top of hull.

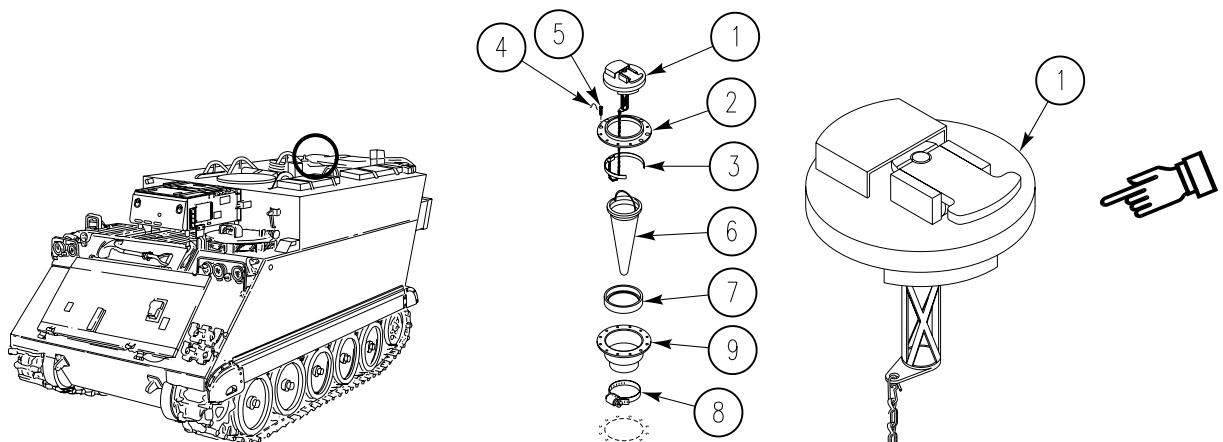

REPLACE FILLER CAP AND STRAINER PARTS (M577A3 AND M1068A3 ONLY) —
Continued

0185 00

INSTALLATION

1. Align mounting holes in boot (9) with mounting holes in hull top. Secure boot (9) to inside fuel tank neck with clamp (8).
2. Secure filler neck (2), retainer (7), strainer (6), and filler cap and chain assembly (1) to hull top with twelve screws (5).
3. Install new lockwire (4) through heads of twelve screws (5). Secure with double twist method.
4. Compress C ring (3) and install through filler neck (2).

NOTE

If fuel cap has pressure relief valve, cap is installed by turning cap clockwise until tight, then push pressure relief handle down.

5. Fasten filler cap and chain assembly (1) in filler neck.

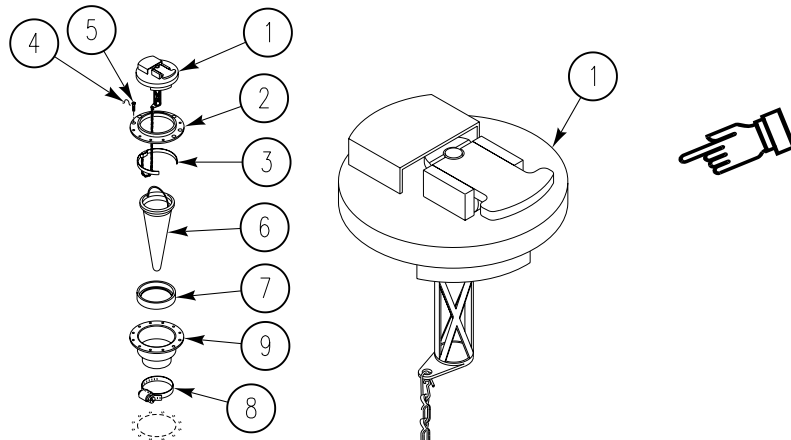

FOLLOW-THROUGH STEPS

1. Connect battery ground lead (WP 0338 00).
2. Close and lock combat filler cover (see your -10).

END OF TASK

REPLACE FUEL FILLER AND STRAINER PARTS (M577A3 AND M1068A3 ONLY)

0186 00

THIS WORK PACKAGE COVERS:

- Removal (page 0186 00-1).
- Cleaning (page 0186 00-2).
- Repair (page 0186 00-2).
- Installation (page 0186 00-2).

INITIAL SETUP:

Maintenance Level

Unit

References

See your -10

Tools and Special Tools

General Mechanic's Tool Kit (WP 0926 00, Item 65)

Equipment Condition

- Engine stopped (see your -10)
- Carrier blocked (see your -10)
- Ramp lowered (see your -10)
- Battery ground lead disconnected (WP 0338 00)
- Filler cover and lock removed (WP 0183 00)
- Filler cap removed (WP 0185 00)
- Fuel tanks drained below filler flange level (WP 0178 00)

Materials/Parts

Sealing compound (WP 0928 00, Item 56)
Gasket (2)

Personnel Required

Unit Mechanic

REMOVAL

1. Disconnect two fuel tank vent hoses (2) from two elbows (3) and remove elbows from filler neck (4).
2. Disconnect APU fuel return tube (5) from tee (6).
3. Disconnect engine fuel return hose (7) from elbow (8).
4. Disconnect fuel tank vent tube (9) from elbow (10) and remove elbow from filler neck (4).
5. Remove elbow (8) from tee (6) and tee from filler neck (4).
6. Remove 12 screws (11) and nuts (12) that secure flange (13), filler neck (4), and two gaskets (14) and (15) to hull top opening. Discard gaskets.
7. Remove strainer element (16), strainer assembly (17), and bushing (18) from hull.
8. Remove screw (19), nut (20), washer (21), clamp (22), and ground lead (23) from filler tube (24).

REPLACE FUEL FILLER AND STRAINER PARTS (M577A3 AND M1068A3 ONLY) —
Continued

0186 00

9. Remove four clamps (25), filler tube (24), filler neck (4), and two hoses (26) from fuel tank flange (1).

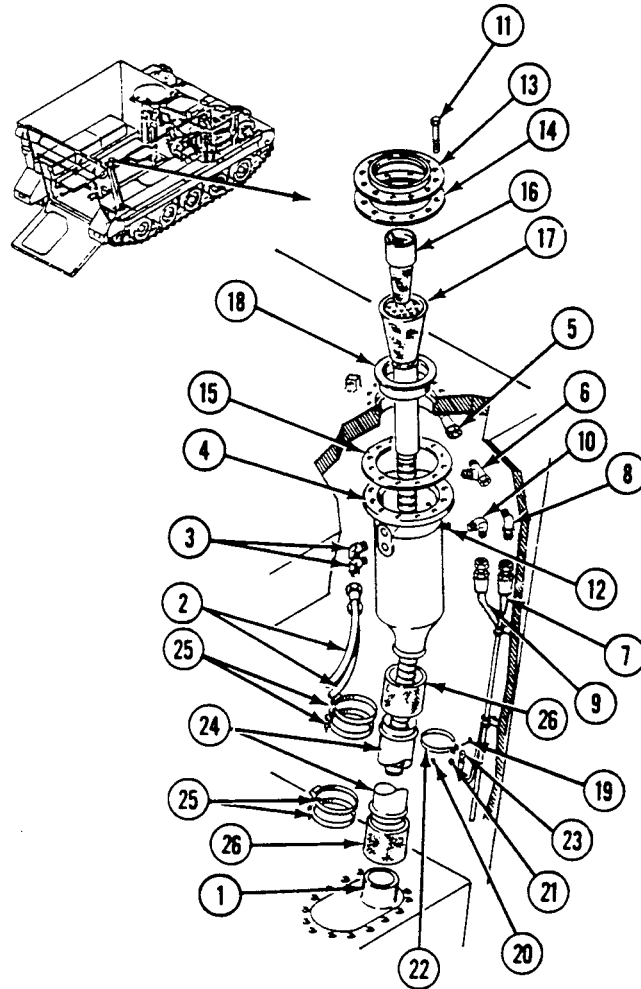
**CLEANING**

1. Clean and check hoses and tubes.
2. Clean and check machined surfaces of parts.

REPAIR OR REPLACEMENT

1. Replace worn, crimped, or cracked hoses and tubes.
2. Repair or replace nicked or dented machined surfaces of parts.

INSTALLATION

1. Apply a thin even coat of sealing compound to clean external threads of fittings before installation.
2. Install two hoses (1), and filler neck (2) with a new gasket (3) and filler tube (4) on filler flange (5). Secure with four clamps (6).
3. Install clamp (7) and ground lead (8) on filler tube (4). Secure with screw (9), washer (10), and nut (11).

REPLACE FUEL FILLER AND STRAINER PARTS (M577A3 AND M1068A3 ONLY) —
Continued

0186 00

4. Install bushing (12), strainer assembly (13), and strainer element (14) into hull top opening and filler neck (2).
5. Install flange (15) and new gasket (16) on hull top opening. Secure flange to filler neck (2) with 12 screws (17) and nuts (18).
6. Install two elbows (19) in filler neck (2) and connect two fuel tank vent hoses (20) to elbows.
7. Install tee (21) on filler neck (2) and install elbow (22) on tee.
8. Install elbow (23) in filler neck (2) and connect fuel tank vent tube (24) to elbow.
9. Connect engine fuel return hose (25) to elbow (22) and APU fuel return tube (26) to tee (21).

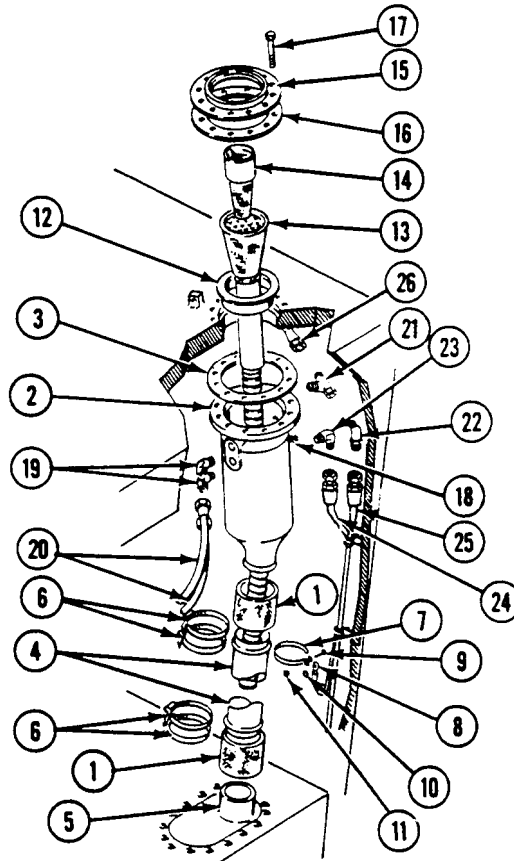
**FOLLOW-THROUGH STEPS**

1. Fill fuel tank (see your -10).
2. Check filler tube and hoses for leaks.
3. Install filler cap (WP 0185 00).
4. Install filler cover and lock (WP 0183 00).
5. Connect battery ground lead (WP 0338 00).
6. Start engine (see your -10).
7. Raise and lock ramp (see your -10).
8. Stop engine (see your -10).

END OF TASK

REPLACE FUEL TANK ACCESS COVERS AND DRAIN PLUGS (ALL EXCEPT M577A3 AND M1068A3)

0187 00

THIS WORK PACKAGE COVERS:

Removal (page 0187 00-1).
 Installation (page 0187 00-2).

INITIAL SETUP:

Maintenance Level

Unit

References

See your -10

Tools and Special Tools

General Mechanic's Tool Kit (WP 0926 00, Item 65)
 Torque Wrench (WP 0926 00, Item 85)

Equipment Condition

Engine stopped (see your -10)
 Carrier blocked (see your -10)
 Battery ground strap disconnected (WP 0337 00) or
 (WP 0339 00)
 Fuel tanks drained (WP 0177 00)

Materials/Parts

Sealing compound (WP 0928 00, Item 56)
 Gasket
 Lockwasher (10)

Personnel Required

Unit Mechanic

REMOVAL

NOTE

Right and left access covers are the same. The following steps apply to one cover.

1. Remove two screws (1), lockwashers (2), flat washers (3), and bracket (4) from cover (5). Discard lockwashers.
2. Remove eight screws (6), lockwashers (7), flat washers (8), cover (5), and gasket (9) from fuel tank (10). Discard gasket and lockwashers.

REPLACE FUEL TANK ACCESS COVERS AND DRAIN PLUGS (ALL EXCEPT M577A3 AND M1068A3) — Continued

0187 00

3. Remove drain plug (11) and bushing (12) from fuel tank (10).

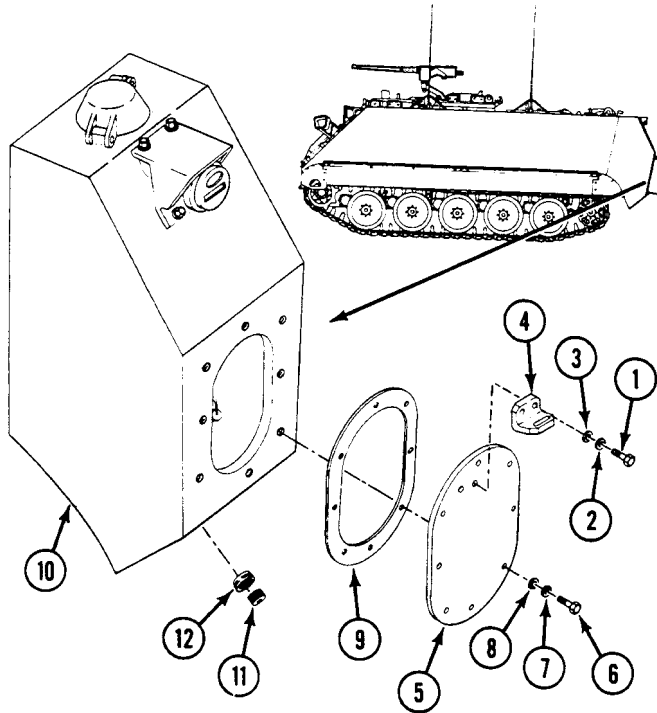
**INSTALLATION**

1. Install cover (5) and new gasket (9) on fuel tank (10). Secure with eight screws (6), new lockwashers (7), and flat washers (8). **TIGHTEN SCREWS TO 45-50 LB-FT (61-68 N·m) TORQUE.**
2. Install bracket (4) on cover (5). Secure with two screws (1), new lockwashers (2), and flat washers (3).
3. Apply a coat of sealing compound to cleaned threads of bushing (12) and drain plug (11).
4. Install bushing (12) in fuel tank (10).

REPLACE FUEL TANK ACCESS COVERS AND DRAIN PLUGS (ALL EXCEPT M577A3 AND M1068A3) — Continued

0187 00

5. Install drain plug (11) in bushing (12).

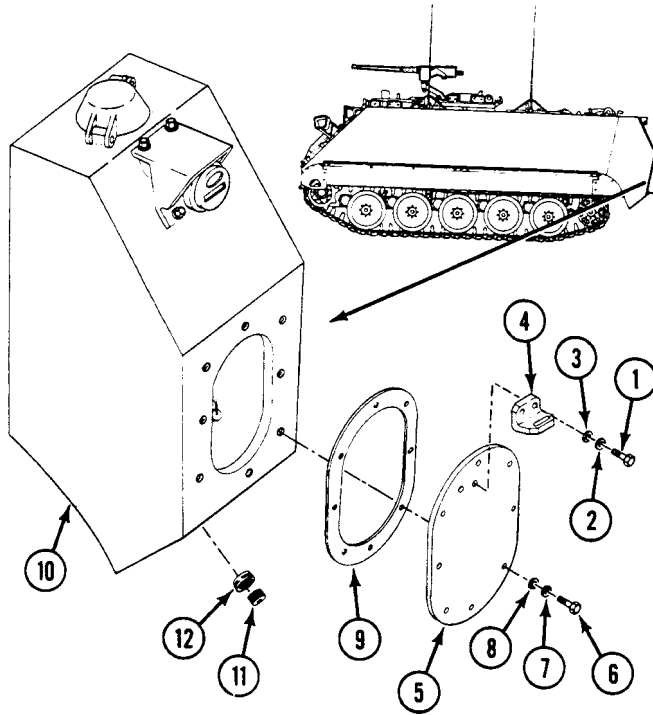

FOLLOW-THROUGH STEPS

1. Fill fuel tanks (see your -10).
2. Check for fuel leaks.
3. Connect battery ground strap (WP 0337 00) or (WP 0339 00).

END OF TASK

REPLACE FUEL TANK ACCESS COVERS (M577A3 AND M1068A3 ONLY)

0188 00

THIS WORK PACKAGE COVERS:

- Removal (page 0188 00-1).
- Installation (page 0188 00-2).

INITIAL SETUP:

Maintenance Level

Unit

References

See your -10

Tools and Special Tools

- General Mechanic's Tool Kit (WP 0926 00, Item 65)
- Socket Wrench Set (WP 0926 00, Item 73)
- Torque Wrench (WP 0926 00, Item 85)

Equipment Condition

- Engine stopped (see your -10)
- Carrier blocked (see your -10)
- Ramp lowered (see your -10)
- Battery access cover removed (see your -10)
- Battery ground lead disconnected (WP 0338 00)
- Map board removed (see your -10)
- Work tables removed (WP 0578 00) or (WP 0581 00) and (WP 0582 00)

Materials/Parts

- Gasket
- Locking plate bolt (8)

Personnel Required

Unit Mechanic

REMOVAL

NOTE

Left and right fuel tank access covers are the same. The following steps apply to one cover.

1. Drain fuel tank below filler flange (WP 0178 00).
2. Remove 16 screws (1) and eight locking plate bolts (2) securing fuel tank access cover (3) and gasket (4) to fuel tank. Discard locking plate bolts.

3. Remove fuel tank access cover (3) and gasket (4) from fuel tank. Discard gasket.

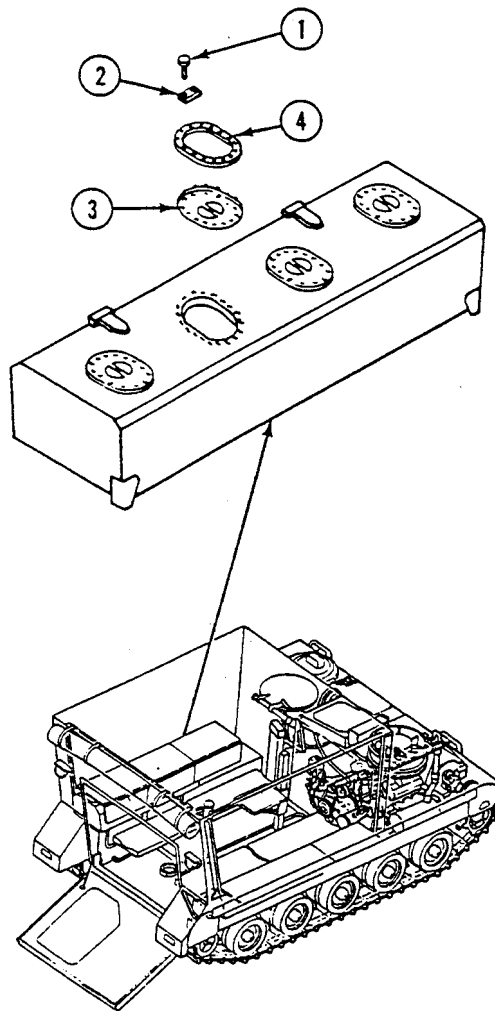

INSTALLATION

1. Place new gasket (4) on access cover (3).
2. Place cover (3) and new gasket (4) inside fuel tank opening. Secure with eight new locking plate bolts (2) and sixteen screws (1).

3. TIGHTEN SIXTEEN SCREWS (1) TO 36-48 LB-IN (4-6 N·m).

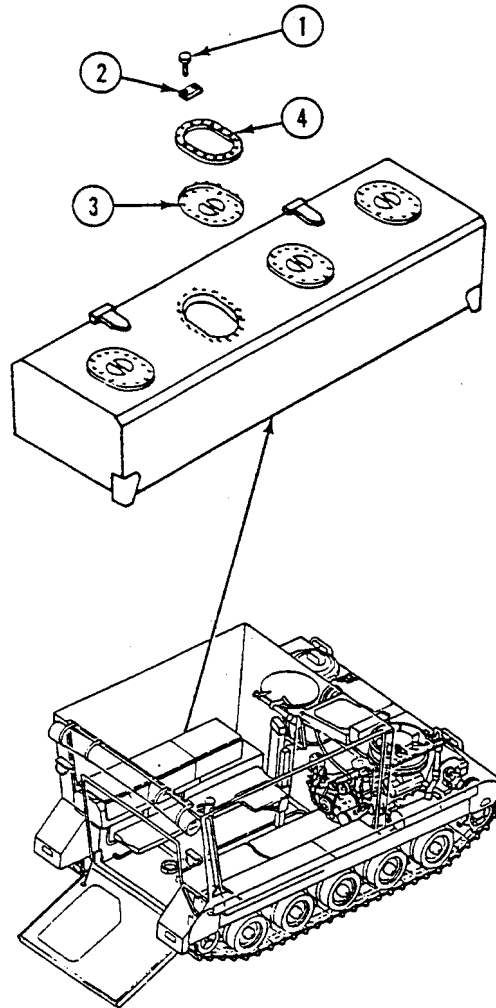

FOLLOW-THROUGH STEPS

1. Fill fuel tank (see your -10). Check tank for leaks.
2. Install work tables (WP 0578 00) or (WP 0581 00) and (WP 0582 00).
3. Install map board (see your -10).
4. Connect battery ground lead (WP 0338 00).
5. Install battery access cover (see your -10).
6. Start engine (see your -10).
7. Raise and lock ramp (see your -10).
8. Stop engine (see your -10).

END OF TASK

REPLACE FUEL TANK FILLER FLANGE (M577A3 AND M1068A3 ONLY)

0189 00

THIS WORK PACKAGE COVERS:

Removal (page 0189 00-1).
 Installation (page 0189 00-2).

INITIAL SETUP:

Maintenance Level

Unit

References

See your -10

Tools and Special Tools

General Mechanic's Tool Kit (WP 0926 00, Item 65)
 Socket Wrench Set (WP 0926 00, Item 73)
 Torque Wrench (WP 0926 00, Item 85)

Equipment Condition

Engine stopped (see your -10)
 Carrier blocked (see your -10)
 Ramp lowered (see your -10)
 Battery access cover removed (see your -10)
 Battery ground lead disconnected (WP 0338 00)
 Map board removed (see your -10)
 Work tables removed (WP 0578 00) or (WP 0581 00)
 and (WP 0582 00)
 Fuel tanks drained below filler flange level (WP 0178 00)

Materials/Parts

Gasket
 Locking plate bolt (8)

Personnel Required

Unit Mechanic

REMOVAL

1. Remove two clamps (1) and filler hose (2) from filler tube (3) and filler flange (4).
2. Remove 16 screws (5), 8 locking plate bolts (6), filler flange (4), and gasket (7) from fuel tank. Discard gasket and locking plate bolts.

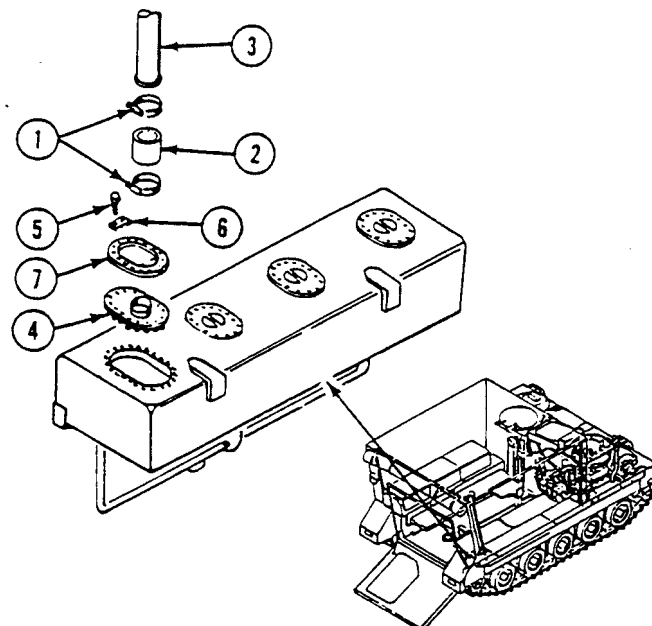

INSTALLATION

1. Place new gasket (7) on filler flange (4).
2. Place filler flange (4) and new gasket (7) inside fuel tank opening. Secure with 8 new locking plate bolts (6) and 16 screws (5).
3. TIGHTEN 16 SCREWS (5) TO 36-48 LB-IN (4-6 N·m) TORQUE.
4. Secure filler hose (2) to filler flange (4) and filler tube (3) with two clamps (1).

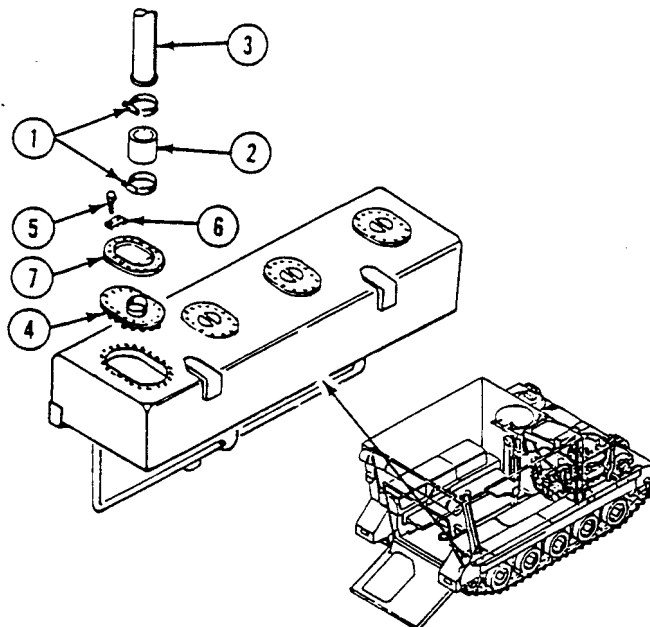
**FOLLOW-THROUGH STEPS**

1. Fill fuel tank (see your -10). Check tank for leaks.
2. Install work tables (WP 0578 00) or (WP 0581 00) and (WP 0582 00).
3. Install map board (see your -10).
4. Connect battery ground lead (WP 0338 00).
5. Install battery access cover (see your -10).
6. Start engine (see your -10).
7. Raise and lock ramp (see your -10)
8. Stop engine (see your -10).

END OF TASK

REPLACE FUEL QUANTITY TRANSMITTER (ALL EXCEPT M577A3 AND M1068A3)

0190 00

THIS WORK PACKAGE COVERS:

- Removal (page 0190 00-1).
- Inspection (page 0190 00-2).
- Repair (page 0190 00-2).
- Installation (page 0190 00-3).

INITIAL SETUP:

Maintenance Level

Unit

Tools and Special Tools

General Mechanic's Tool Kit (WP 0926 00, Item 65)

Materials/Parts

Sealing compound (WP 0928 00, Item 56)

Personnel Required

Unit Mechanic

References

See your -10

Equipment Condition

- Engine stopped (see your -10)
- Carrier blocked (see your -10)
- Battery ground strap disconnected (WP 0337 00) or (WP 0339 00)
- Fuel tanks drained (WP 0177 00)
- Fuel tank access covers removed (WP 0187 00)
- Tail lights and guards removed (WP 0298 00)

REMOVAL

NOTE

Right and left fuel quantity transmitters are replaced the same. The following steps apply to one unit.

1. Disconnect lead (1) from transmitter (2). Circuit 30A is left tank transmitter lead. Circuit 31A is right tank transmitter lead.
2. Remove two screws (3), washers (4), bracket (5), and transmitter (2) from fuel tank (6).
3. Remove screw (7), washer (8), and clamp (9) that secures lead (1) to fuel tank (6).
4. Remove connector (10) and lead (1) from fuel tank (6).

REPLACE FUEL QUANTITY TRANSMITTER (ALL EXCEPT M577A3 AND M1068A3) —
Continued

0190 00

5. Remove five screws (11) and nuts (12). Separate transmitter (2) from bracket (5).

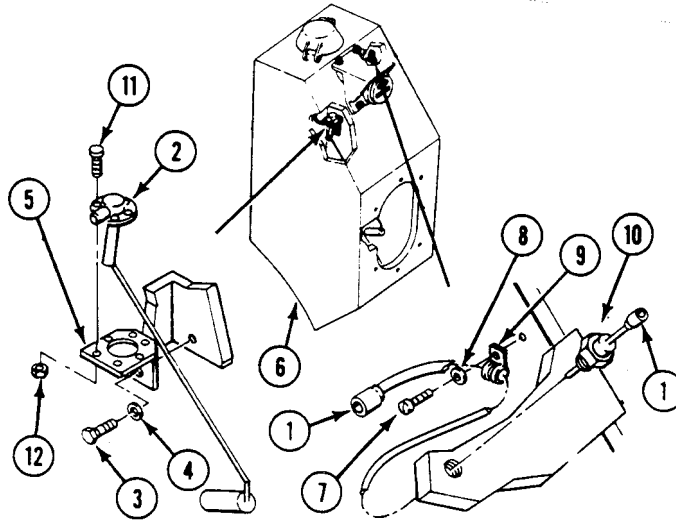
**INSPECTION-ACCEPTANCE AND REJECTION CRITERIA**

1. Inspect bracket.
2. Inspect connector.

REPAIR OR REPLACEMENT

1. Replace bracket if cracked.
2. Replace connector that is cracked or has stripped threads (WP 0382 00).

REPLACE FUEL QUANTITY TRANSMITTER (ALL EXCEPT M577A3 AND M1068A3) —
Continued

0190 00

INSTALLATION

1. Apply a thin coat of sealing compound to cleaned external threads of connector (1) before installation.
2. Secure transmitter (2) to bracket (3) with five screws (4) and nuts (5).
3. Install bracket (3) and transmitter (2) on fuel tank (6). Secure with two screws (7) and washers (8).
4. Install lead (9) and connector (1) in tank (6).
5. Connect lead (9) to transmitter (2). Circuit 30A is left tank transmitter lead. Circuit 31A is right tank transmitter lead.
6. Secure lead (9) to tank (6) with clamp (10), washer (11), and screw (12).

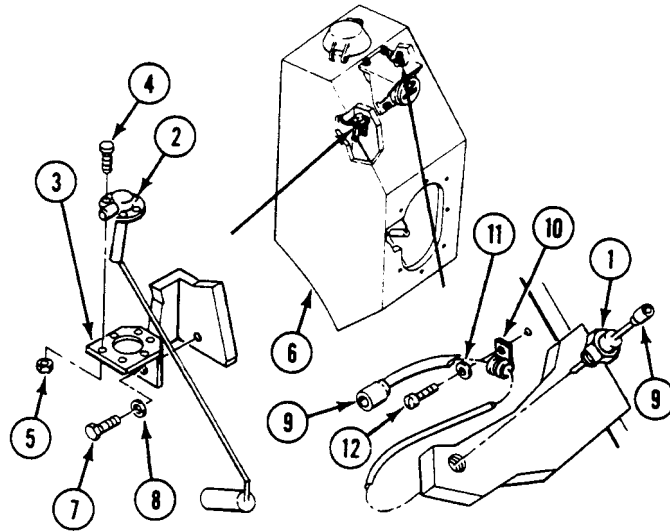
**FOLLOW-THROUGH STEPS**

1. Install tail lights and guards (WP 0298 00).
2. Install fuel tank access covers (WP 0187 00).
3. Fill fuel tanks (see your -10).
4. Connect battery ground strap (WP 0337 00) or (WP 0339 00).
5. Check that fuel quantity transmitter works properly (see your -10).

END OF TASK

REPLACE FUEL QUANTITY TRANSMITTER (M577A3 AND M1068A3 ONLY)

0191 00

THIS WORK PACKAGE COVERS:

- Removal (page 0191 00-1).
 - Cleaning (page 0191 00-2).
 - Installation (page 0191 00-2).
-

INITIAL SETUP:

Maintenance Level

Unit

References

See your -10

Tools and Special Tools

General Mechanic's Tool Kit (WP 0926 00, Item 65)

Equipment Condition

- Engine stopped (see your -10)
- Carrier blocked (see your -10)
- Ramp lowered (see your -10)
- Battery ground lead disconnected (WP 0338 00)
- Map board removed (see your -10)
- Work tables removed (WP 0578 00) or (WP 0581 00) and (WP 0582 00)
- Fuel tanks drained to less than 3/4 full (WP 0178 00)

Materials/Parts

- Cleaning Compound (WP 0928 00, Item 19)
- Nonelectrical Wire (WP 0928 00, Item 42)
- Gasket

Personnel Required

Unit Mechanic

REMOVAL

NOTE

Right and left fuel quantity transmitter are the same. The following steps apply to only one transmitter.

1. Disconnect lead (1) from transmitter (2). Circuit 29 lead is for right transmitter. Circuit 30 lead is for left transmitter.
2. Remove lockwire (3) from five screws (4). Discard lockwire.

3. Remove five screws (4), ground lead (5), transmitter (2), and gasket (6) from fuel tank. Discard gasket.

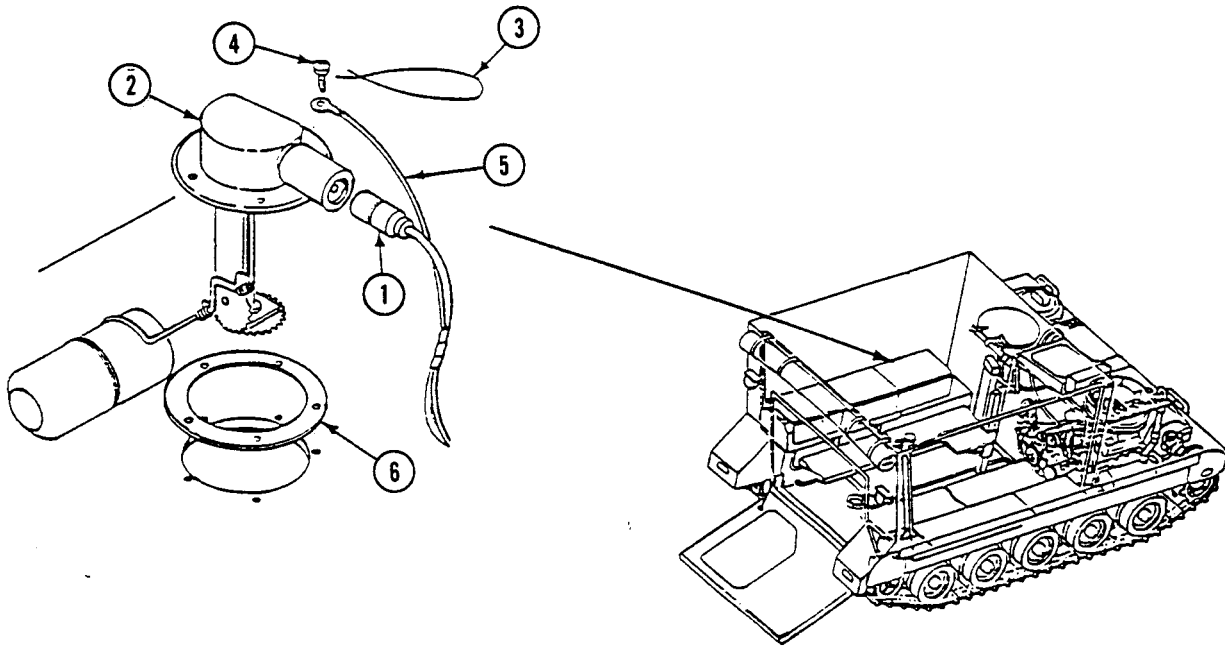

CLEANING

1. Clean gasket mating surface on top of fuel tank with cleaning compound.

INSTALLATION

1. Install new gasket (1), transmitter (2), and ground lead (3) on fuel tank. Secure with five screws (4).

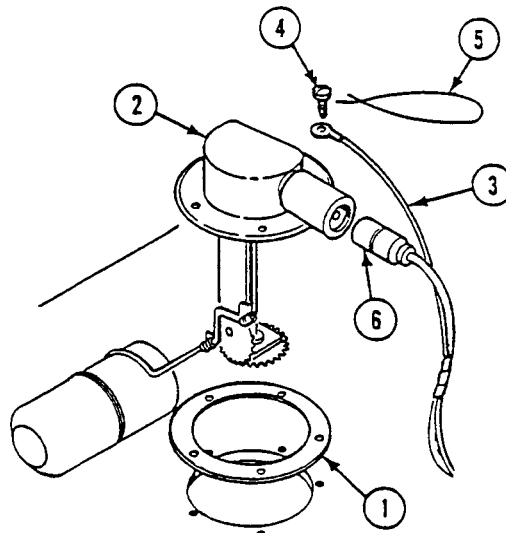

2. Install new lockwire (5) through heads of five screws (4). Secure with double twist method.

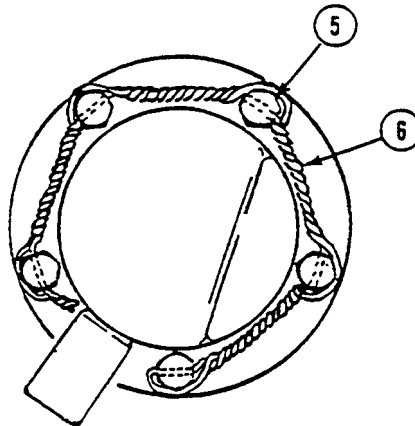

3. Connect lead (6) to transmitter (2). Circuit 29 is lead for right transmitter. Circuit 30 is lead for left transmitter.

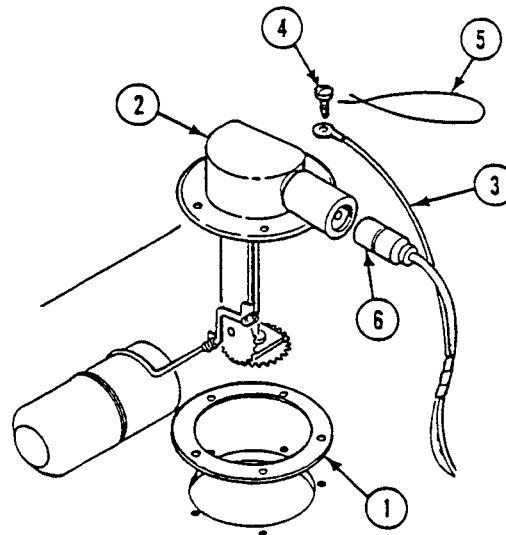

FOLLOW-THROUGH STEPS

1. Fill fuel tank. Check for leaks (see your -10).
2. Connect battery ground lead (WP 0338 00).
3. Check that fuel quantity transmitter operates properly (see your -10).
4. Install work tables (WP 0578 00) or (WP 0581 00) and (WP 0582 00).
5. Install map board (see your -10).
6. Start engine (see your -10).
7. Raise and lock ramp (see your -10).
8. Stop engine (see your -10).

END OF TASK

REPLACE FUEL SUPPLY HOSES, TUBES, AND FITTINGS (M113A3, M1059A3, AND M58 ONLY)

0192 00

THIS WORK PACKAGE COVERS:

Removal (page 0192 00-1).
 Installation (page 0192 00-8).

INITIAL SETUP:

Maintenance Level

Unit

Tools and Special Tools

General Mechanic's Tool Kit (WP 0926 00, Item 65)

Materials/Parts

Caulking compound (WP 0928 00, Item 14)

Sealing compound (WP 0928 00, Item 53)

Grommet

Lockwasher (6)

Personnel Required

Unit Mechanic

References

See your -10

TM 3-1040-285-20

Equipment Condition

Engine stopped (see your -10)

Carrier blocked (see your -10)

Ramp lowered

Power plant lower rear access panel removed
 (see your -10)

Floor plates removed (WP 0539 00), (WP 0542 00) and
 (WP 0545 00)

Battery ground strap disconnected (WP 0337 00)

Fuel tanks drained (WP 0177 00)

Smoke generator fog oil tank module removed
 (M1059A3 only) (WP 0753 00)

Smoke generator system removed (M58 only)
 (TM 3-1040-285-20)

**REPLACE FUEL SUPPLY HOSES, TUBES, AND FITTINGS (M113A3,
M1059A3, AND M58 ONLY) — Continued**

0192 00

REMOVAL

1. Remove quick disconnect (1) from coupler body (2).
2. Remove hose (3) from elbow (4).
3. Remove grommet (5) and hose (3) from bulkhead. Discard grommet.

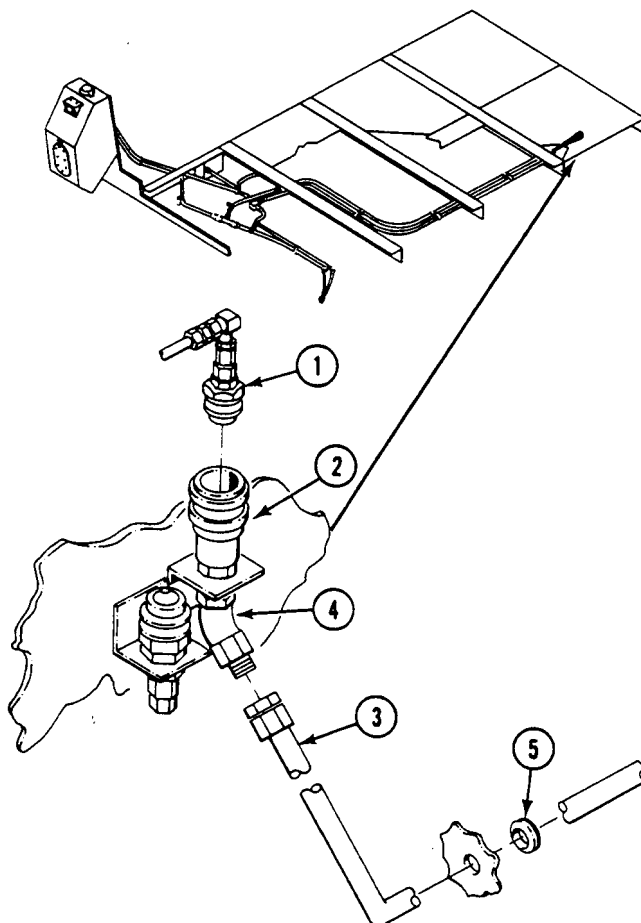

NOTE

Step 4, Step 5, and Step 6 refer to M58 only.

4. Remove hose (1) from tube cross (2).
5. Remove five screws (3), lockwashers (4), clamps (5), and hose (1) from carrier. Discard lockwashers.
6. Remove hoses (6 and 6.1) from tube cross (2). Remove tube cross from carrier.

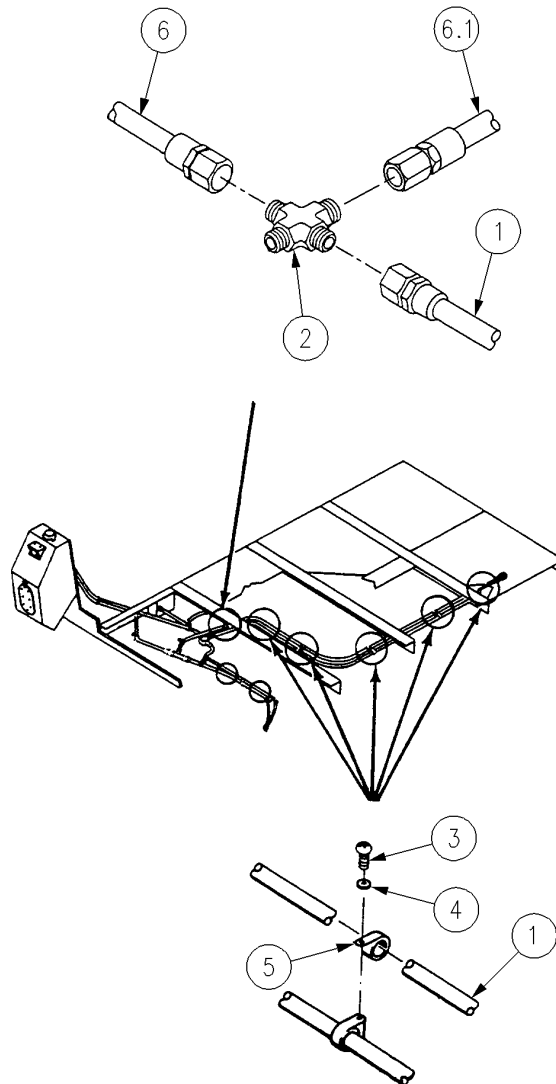

**REPLACE FUEL SUPPLY HOSES, TUBES, AND FITTINGS (M113A3,
M1059A3, AND M58 ONLY) — Continued**

0192 00

7. Remove screw (7), lockwasher (8), and clamp (9) from hose (6) and carrier. Discard lockwasher.
8. Remove hose (6) from adapter (10). Remove hose from carrier.
9. Remove adapter (10) from tee (11).

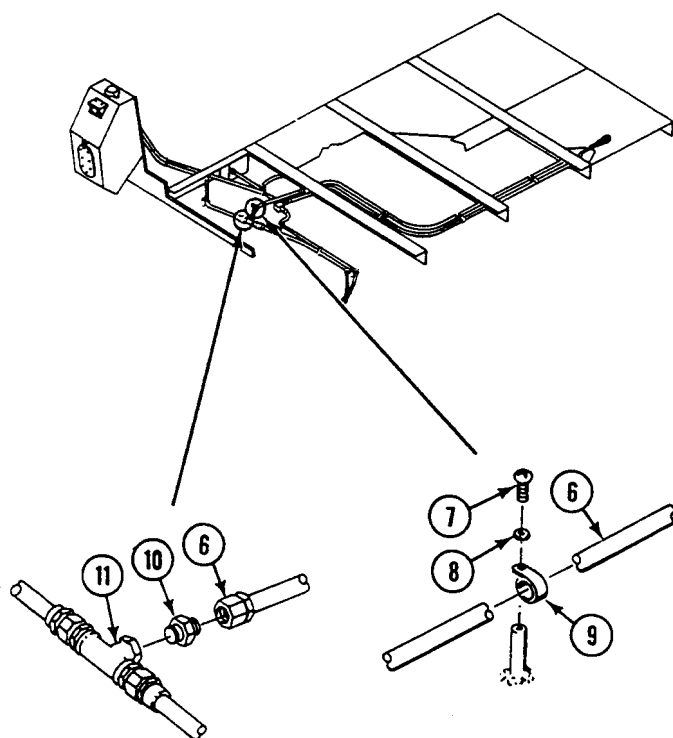

NOTE

Do Steps 10 - 24 for removing left side fuel tank supply hoses and fittings. Do Steps 25 - 38 for removing right side fuel tank supply hoses and fittings.

10. Remove hose (12) from adapter (20).
11. Remove adapter (20) from tee (11).
12. Remove three screws (21), lockwashers (22), and clamps (23) from hose (12) and carrier. Discard lockwashers.
13. Remove tiedown strap (14) from two hoses (12) and (13).
14. Remove locknut (18) and screw (17) from guard (16). Discard locknut.
15. Remove screw (19), washer (15), and guard (16) from ramp pulley mount.

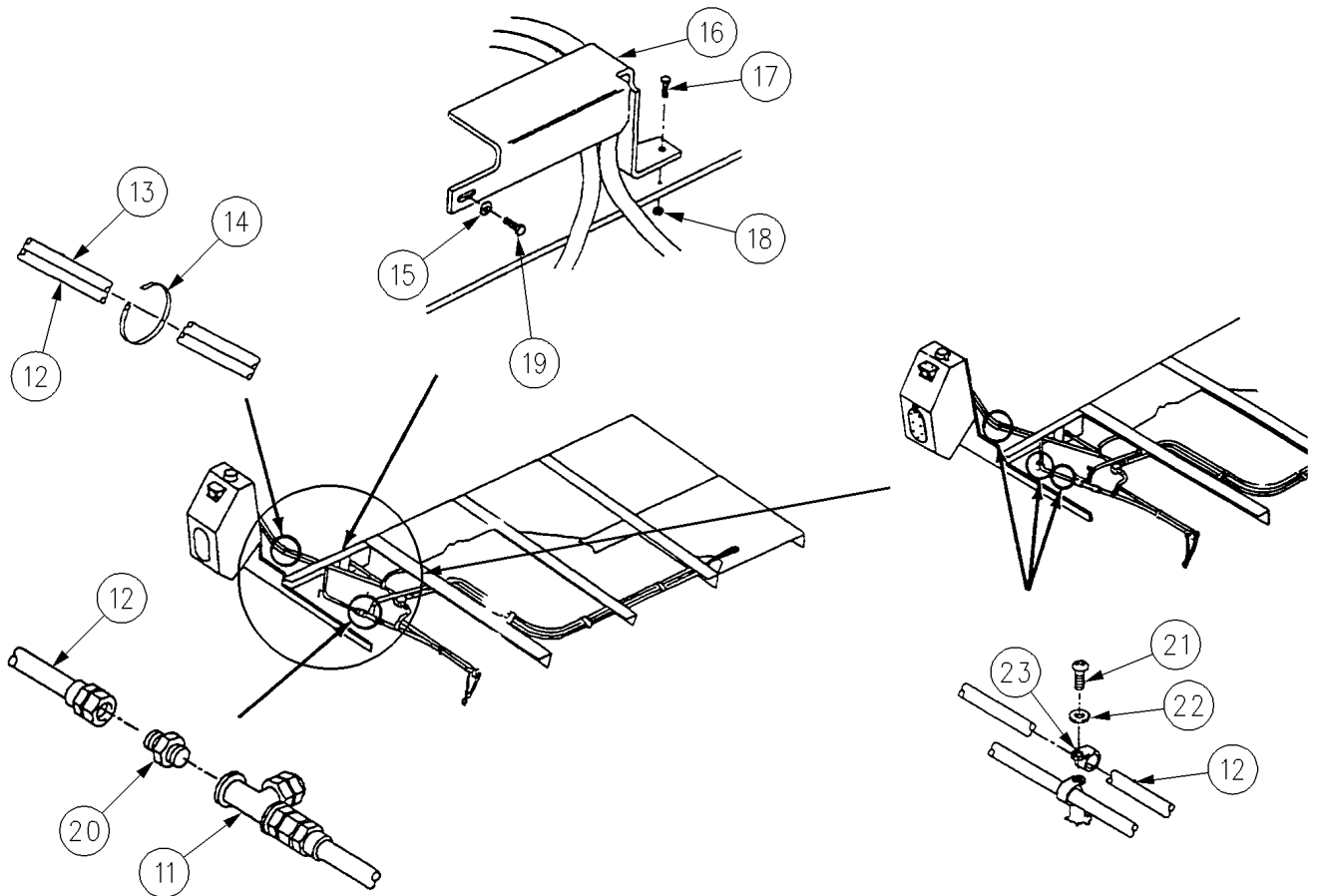

**REPLACE FUEL SUPPLY HOSES, TUBES, AND FITTINGS (M113A3,
M1059A3, AND M58 ONLY) — Continued**

0192 00

16. Remove two screws (24), washers (25), and clamps (26) securing valve (28) to mounting block (29).
17. Remove hose (12) from adapter (30). Remove hose from carrier.
18. Remove adapter (30) from adapter (31).
19. Remove adapter (31) from valve (28).
20. Remove hose (32) from adapter (33).
21. Remove adapter (33) from valve (28).
22. Remove hose (32) from elbow (34).
23. Remove elbow (34) from adapter (35).
24. Remove adapter (35) from fuel tank (36).

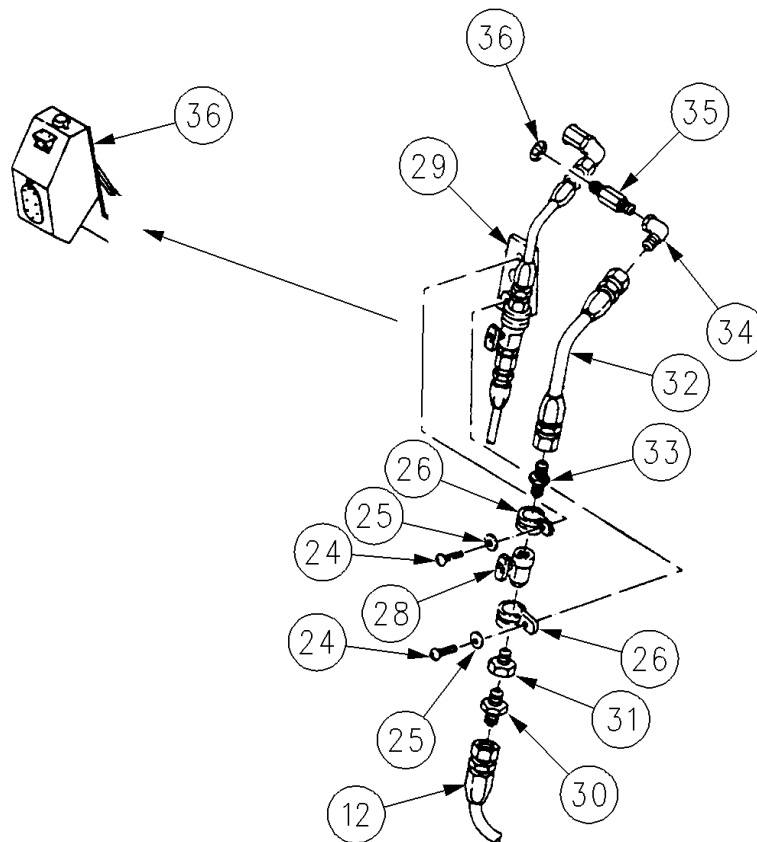

REPLACE FUEL SUPPLY HOSES, TUBES, AND FITTINGS (M113A3, M1059A3, AND M58 ONLY) — Continued

0192 00

25. Remove hose (37) from adapter (38).
26. Remove adapter (38) from tee (11).
27. Remove two screws (39), lockwashers (40), and clamps (41) from hose (37) and carrier. Discard lockwashers.
28. Remove two tiedown straps (14) from two hoses (37) and (37.1).

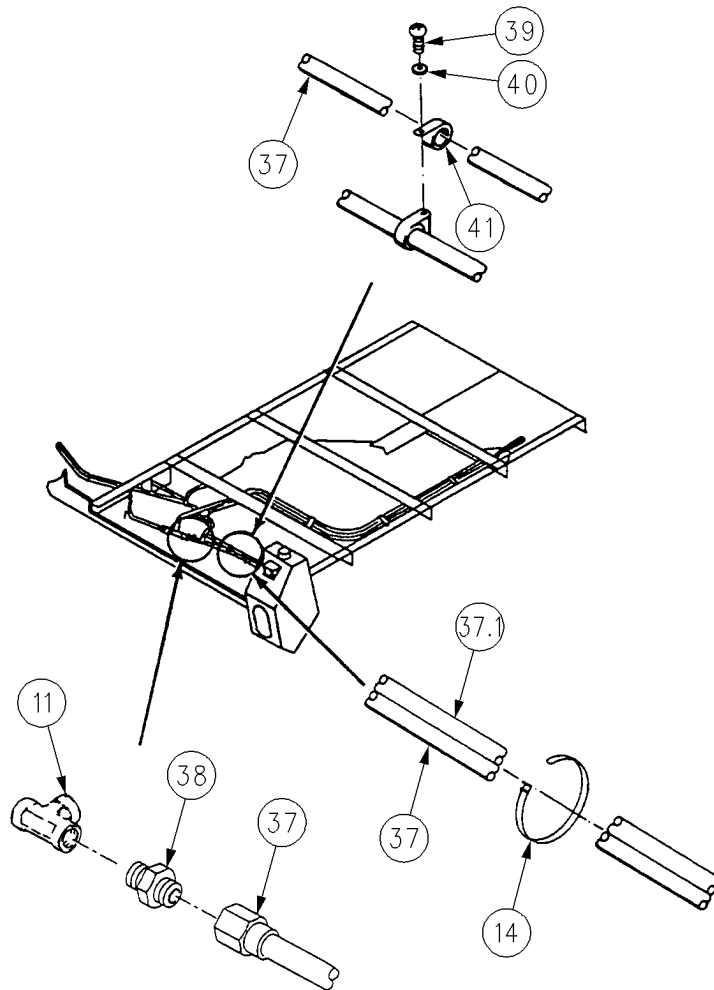

REPLACE FUEL SUPPLY HOSES, TUBES, AND FITTINGS (M113A3, M1059A3, AND M58 ONLY) — Continued

0192 00

29. Remove screw (42), washer (43), and clamp (44) securing valve (45) to mounting block (46).
30. Remove hose (37) from adapter (47). Remove hose from carrier.
31. Remove adapter (47) from adapter (48).
32. Remove adapter (48) from valve (45).
33. Remove hose (49) from adapter (50).
34. Remove adapter (50) from valve (45).
35. Remove five screws (51), washers (52), lockwashers (53), and guard (54) from rear plate and sponson. Discard lockwashers.
36. Remove hose (49) from elbow (55). Remove hose from carrier.
37. Remove elbow (55) from adapter (56).
38. Remove adapter (56) from fuel tank (57).

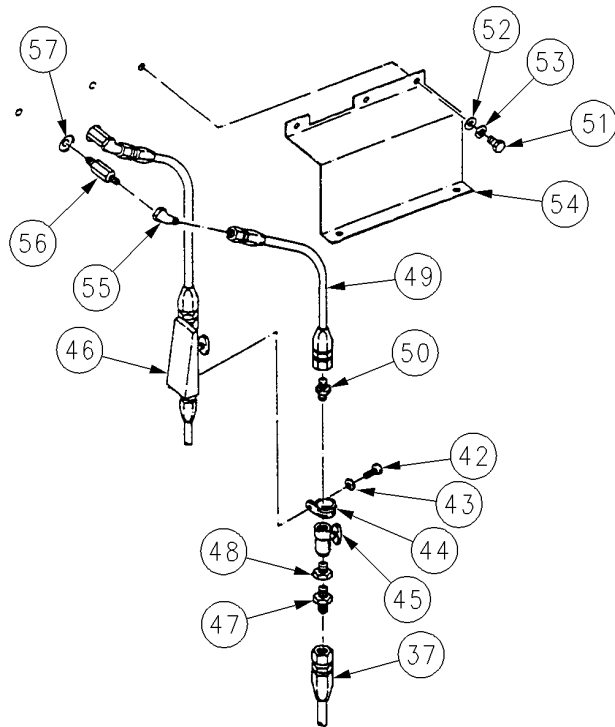
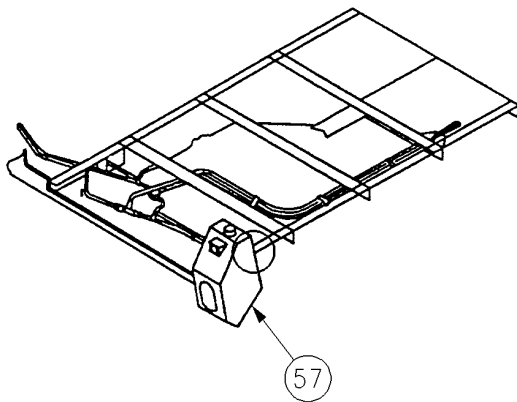

INSTALLATION

NOTE

Do Steps 1 - 15 for installing right side fuel tank supply hoses and fittings. Do Steps 16 - 30 for installing left side fuel tank supply hoses and fittings.

1. Apply sealing compound to external threads of adapter (1). Install adapter (1) on fuel tank (2).
2. Apply sealing compound to external threads of elbow (3). Install elbow (3) on adapter (1).
3. Apply caulking compound to space around adapter (1) on rear hull plate.
4. Install hose (4) on elbow (3).
5. Install guard (5) on rear plate and sponson and secure with five washers (6), lockwashers (7), and screws (8).
6. Apply sealing compound to external threads of adapter (9). Install adapter in valve (10).
7. Install hose (4) on adapter (9).
8. Apply sealing compound to external threads of adapter (11). Install adapter in valve (10).
9. Apply sealing compound to external threads of adapter (12). Install adapter on adapter (11).
10. Install hose (13) on adapter (12).
11. Secure valve (10) to mounting block (14) with clamp (15), washer (16), and screw (17).

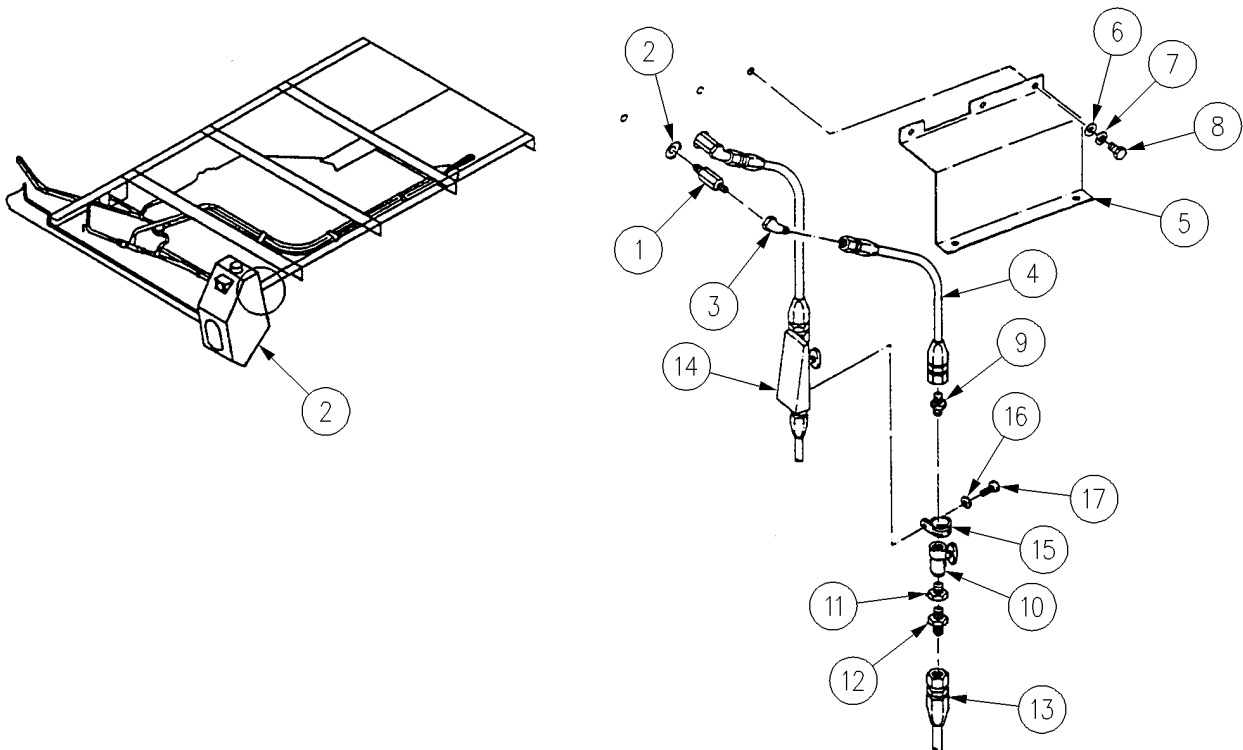

**REPLACE FUEL SUPPLY HOSES, TUBES, AND FITTINGS (M113A3,
M1059A3, AND M58 ONLY) — Continued**

0192 00

12. Apply sealing compound to external threads of adapter (18). Install adapter on tee (19).
13. Install hose (13) on adapter (18).
14. Install two clamps (20) on hose (13). Secure clamps to carrier with two screws (21) and new lockwashers (22).
15. Install two tiedown straps (23) on hoses (13) and (24).

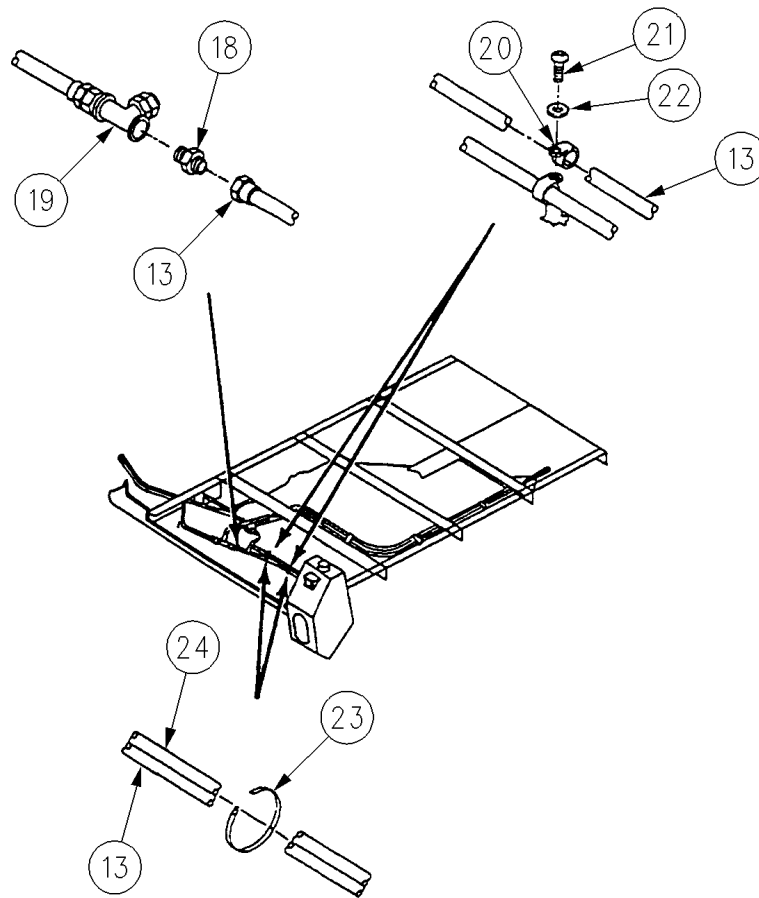

REPLACE FUEL SUPPLY HOSES, TUBES, AND FITTINGS (M113A3, M1059A3, AND M58 ONLY) — Continued

16. Apply sealing compound to external threads of adapter (25). Install adapter on fuel tank (26).
17. Apply sealing compound to external threads of elbow (27). Install elbow on adapter (25).
18. Apply caulking compound to space around adapter (25) on rear hull plate.
19. Install hose (28) on elbow (27).
20. Apply sealing compound to external threads of adapter (29). Install adapter on valve (30).
21. Install hose (28) on adapter (29).
22. Apply sealing compound to external threads of adapter (31). Install adapter on valve (30).
23. Apply sealing compound to external threads of adapter (32). Install adapter on adapter (31).
24. Install hose (33) on adapter (32).
25. Secure valve (30) to mounting block (34) with two clamps (35), washers (36), and screws (37).

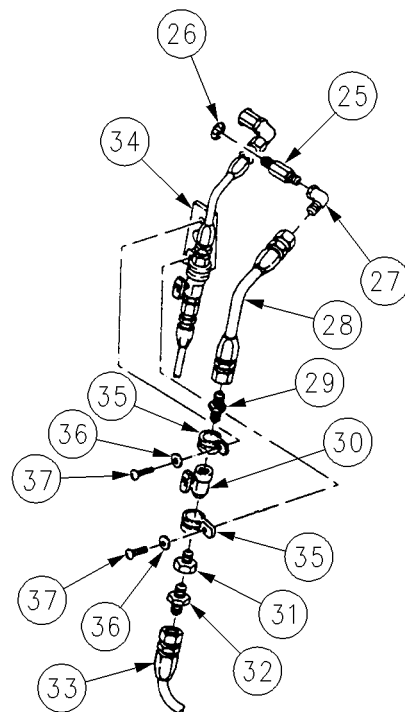
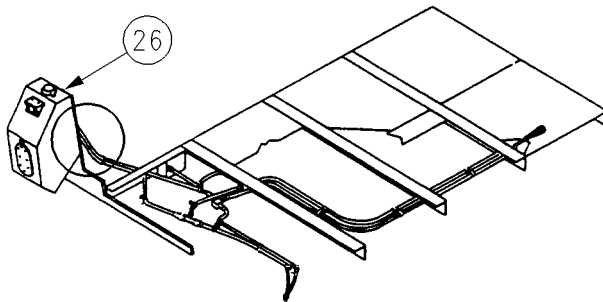

**REPLACE FUEL SUPPLY HOSES, TUBES, AND FITTINGS (M113A3,
M1059A3, AND M58 ONLY) — Continued**

0192 00

26. Apply sealing compound to external threads of adapter (38). Install adapter on tee (39).
27. Install hose (40) on adapter (38).
28. Apply sealing compound to external threads of adapter (41). Install adapter on tee (39).

NOTE

Step 29 is for M58 only.

29. Install hose (42) on adapter (41) and tube cross (43).
30. Install clamp (44) on hose (42). Secure clamp to carrier with screw (45) and new lockwasher (46).

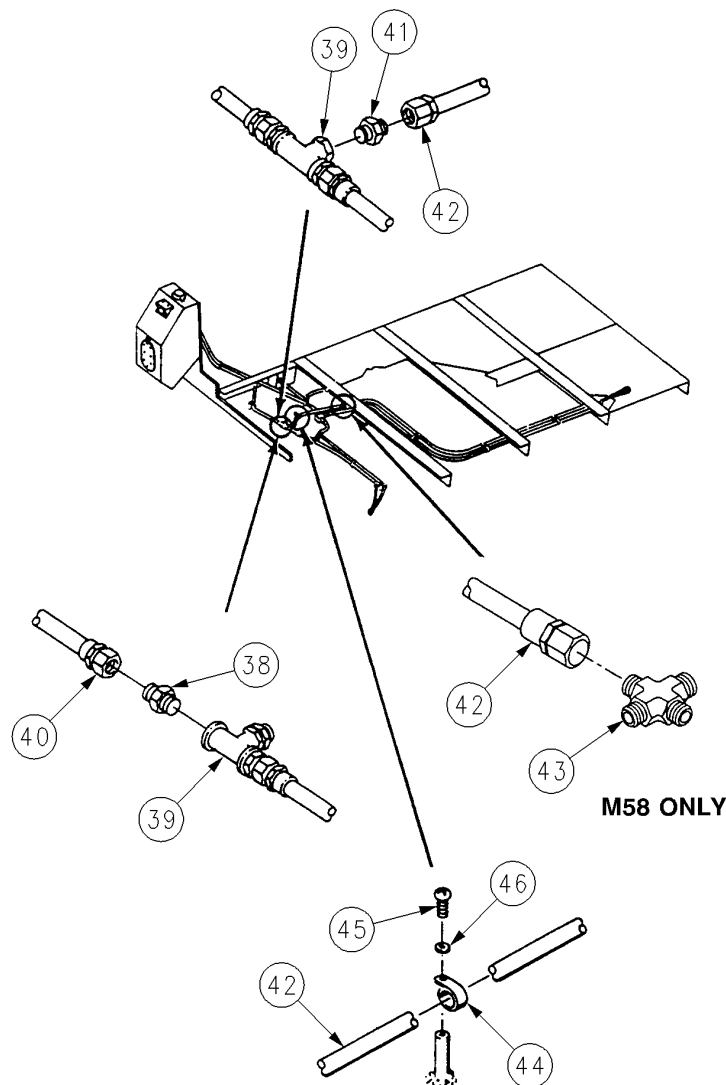

REPLACE FUEL SUPPLY HOSES, TUBES, AND FITTINGS (M113A3, M1059A3, AND M58 ONLY) — Continued

0192 00

31. Install three clamps (47) on hose (40). Secure clamps to carrier with three screws (48) and new lockwashers (49).
32. Place guard (50) over hoses (40) and (51). Secure guard with screw (52), new locknut (53), washer (54), and screw (55).
33. Install tiedown strap (56) on hoses (40) and (51).

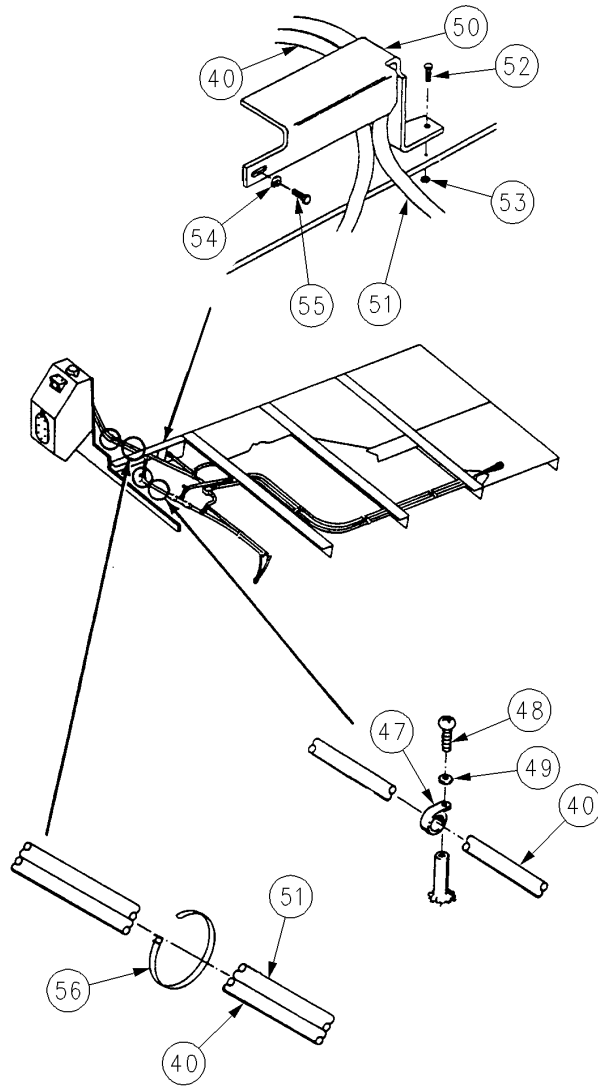

NOTE

Step 34 is for M58 only.

34. Install hoses (57 and 57.1) on tube cross (43).
35. Install five clamps (58) on hose (57). Secure clamps to carrier with five screws (59) and new lockwashers (60).

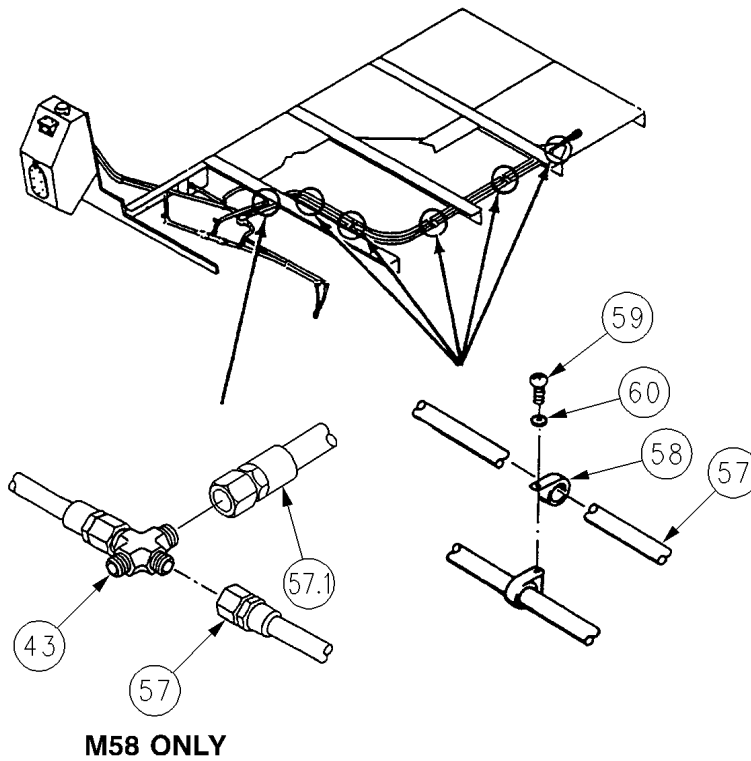

**REPLACE FUEL SUPPLY HOSES, TUBES, AND FITTINGS (M113A3,
M1059A3, AND M58 ONLY) — Continued**

0192 00

36. Install grommet (61) on hose (57). Route hose through hole in bulkhead and install grommet in bulkhead.
37. Install hose (57) on elbow (62). Hold elbow when tightening hose.
38. Install quick disconnect (63) on coupler body (64).

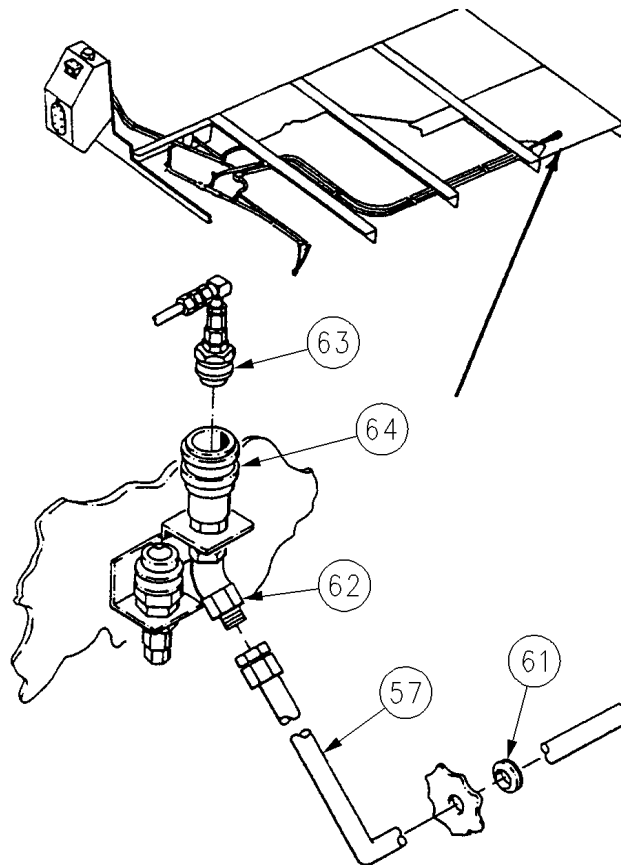

**REPLACE FUEL SUPPLY HOSES, TUBES, AND FITTINGS (M113A3,
M1059A3, AND M58 ONLY) — Continued**

0192 00

FOLLOW-THROUGH STEPS

1. Fill fuel tanks (see your -10).
2. Connect battery ground strap (WP 0337 00).
3. Start engine (see your -10). Check for leaks.
4. Stop engine (see your -10).
5. Install floor plates (see Table of Contents).
6. Install power plant lower rear access panel (see your -10).

NOTE**Do Step 7, Step 8, and Step 10 for M1059A3 only.**

7. Disconnect battery ground strap (WP 0337 00).
8. Install smoke generator fog oil tank module (M1059A3 only) (WP 0753 00).
9. Install smoke generator system (M58 only) (TM 3-1040-285-20).
10. Connect battery ground strap (WP 0337 00).
11. Start engine (see your -10).
12. Raise and lock ramp (see your -10).
13. Stop engine (see your -10).

END OF TASK

REPLACE FUEL SUPPLY HOSES, TUBES AND FITTINGS (M577A3 AND M1068A3 ONLY)

0193 00

THIS WORK PACKAGE COVERS:

Removal (page 0193 00-1).
 Installation (page 0193 00-5).

INITIAL SETUP:

Maintenance Level

Unit

References

See your -10

Tools and Special Tools

General Mechanic's Tool Kit (WP 0926 00, Item 65)

Equipment Condition

Engine stopped (see your -10)
 Carrier blocked (see your -10)
 Ramp lowered (see your -10)
 Battery ground lead disconnected (WP 0338 00)
 Fuel tanks drained (WP 0178 00)
 Power plant rear access panel removed (WP 0439 00)
 Rear compartment floor plates removed (WP 0539 00) or
 (WP 0544 00)

Materials/Parts

Sealing compound (WP 0928 00, Item 56)
 Wiping rag (WP 0928 00, Item 65)
 Grommet
 Locknut (4)
 Lockwasher (14)

Personnel Required

Unit Mechanic

REMOVAL

WARNING



Fuel flowing over a metal surface causes static electricity. This will cause a spark unless the surface is grounded.

NOTE

Use wiping rag to wipe up any spilled fuel.

1. Disconnect personnel heater fuel hose (1) from shutoff valve (2), if installed.
2. Remove shutoff valve (2) and nipple (3) from tube (4).
3. Remove four screws (5) and lockwashers (6) that secure four ground leads (7), clamps (8), and two elbows (9) to four weldnuts (10). Discard lockwashers.

REPLACE FUEL SUPPLY HOSES, TUBES AND FITTINGS (M577A3 AND M1068A3 ONLY)

0193 00

— Continued

4. Remove four locknuts (11), lockwashers (12), and screws (13) that secure four leads (7) and clamps (14) to elbows (9) and tubes (4) and (15). Discard locknuts and lockwashers.

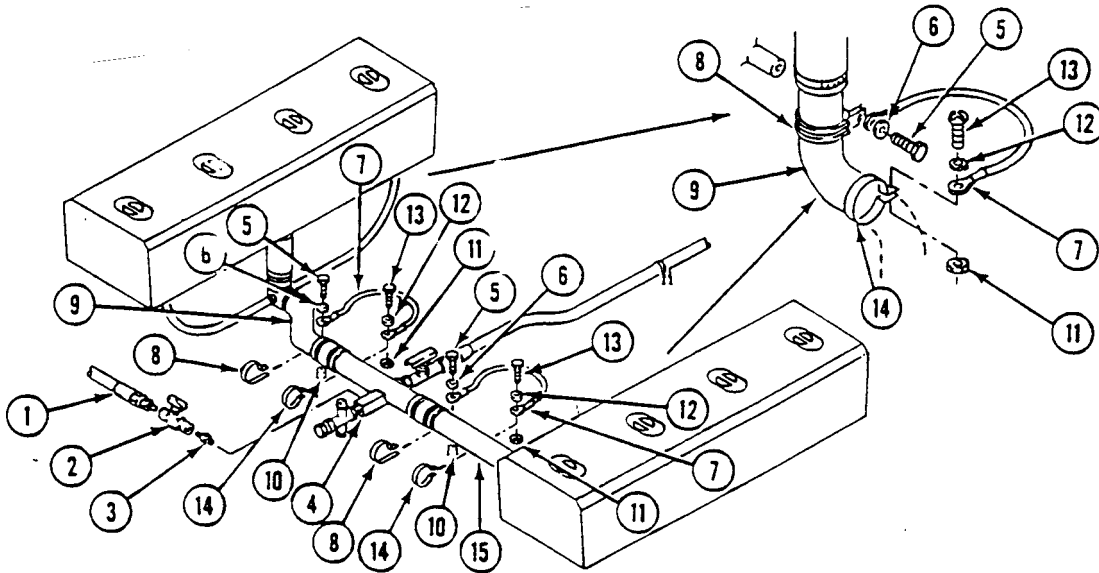

5. Remove plug (1) draincock (2), nipple (3), and bushing (4) from tube (5). Separate plug from draincock, draincock from nipple, and nipple from bushing.
6. Remove four screws (6), lockwashers (7), and clamps (8) that secure four hose assemblies (9) to weldnuts (10). Discard lockwashers.

REPLACE FUEL SUPPLY HOSES, TUBES AND FITTINGS (M577A3 AND M1068A3 ONLY)

0193 00

— Continued

7. Disconnect four hose assemblies (9) from nipples (11).
8. Remove four nipples (11) from two fuel tanks (12).
9. Disconnect four hose assemblies (9) from two elbows (13).
10. Remove two clamps (14) and hose (15) from elbow (13) and tube (5).
11. Remove two clamps (16) and hose (17) from elbow (13) and tube (18).
12. Remove screw (19), lockwasher (20), and clamp (21) that secure elbow (13) to weldnut (22). Discard lockwasher.
13. Remove two clamps (23) and hose (24) from two tubes (5) and (18).
14. Remove four clamps (25) that secure two hoses (26) to two elbows (13) and fuel tanks (12). Remove hoses.

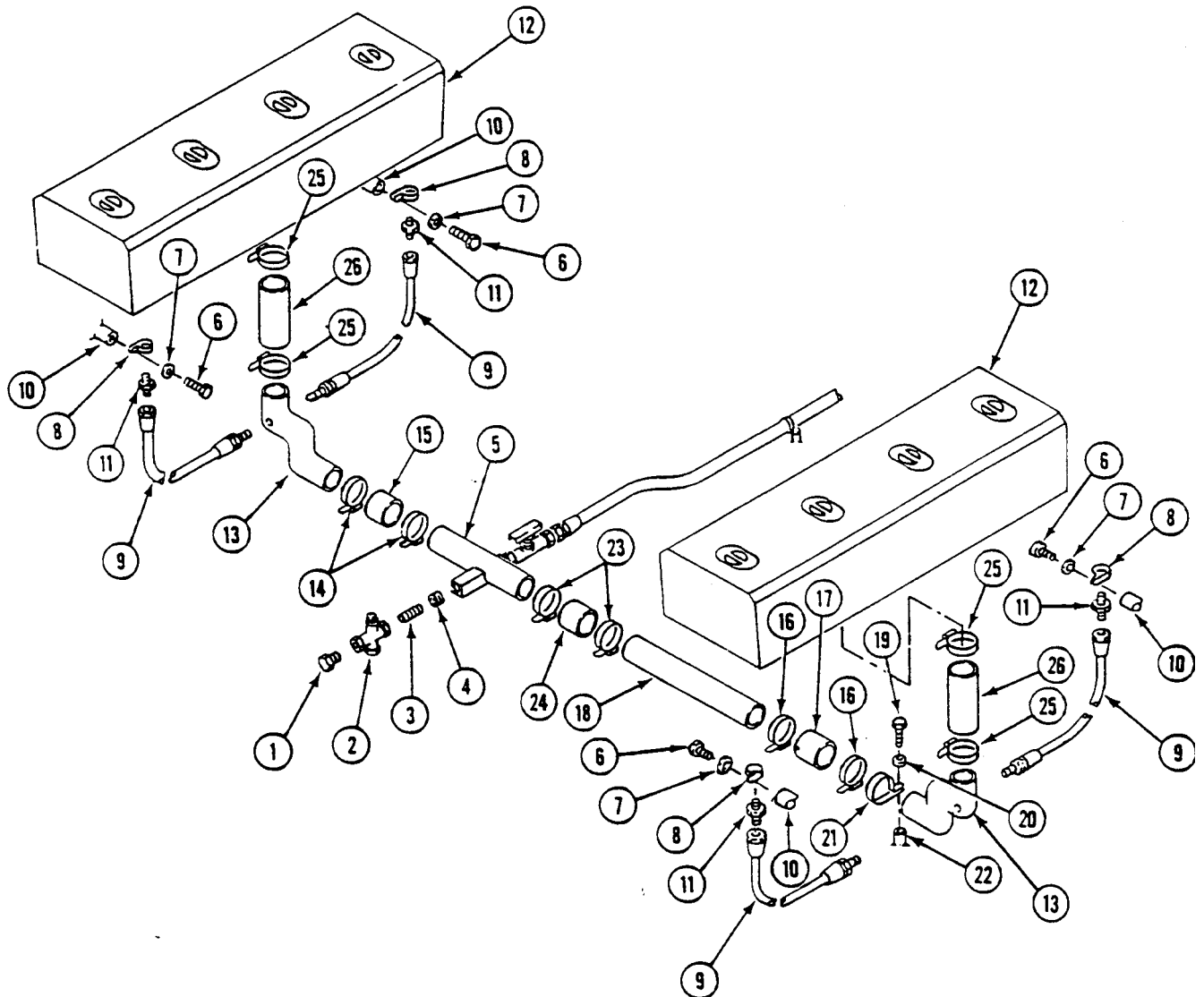

REPLACE FUEL SUPPLY HOSES, TUBES AND FITTINGS (M577A3 AND M1068A3 ONLY)
— Continued

0193 00

15. Disconnect hose (1) from adapter (2).
16. Remove adapter (2), shutoff valve (3), and nipple (4) from tube (5).

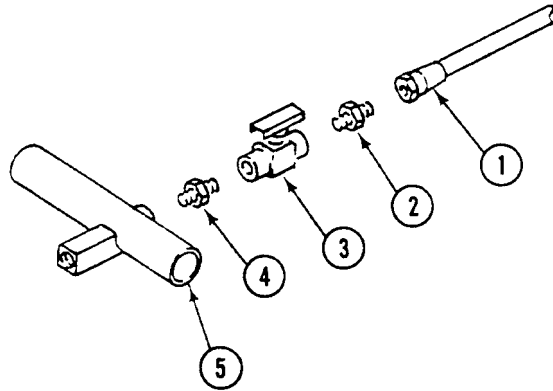

17. Remove quick disconnect (6) from coupler (7).
18. Remove hose (1) from elbow (8).
19. Remove grommet (9) and hose (1) from bulkhead. Discard grommet.

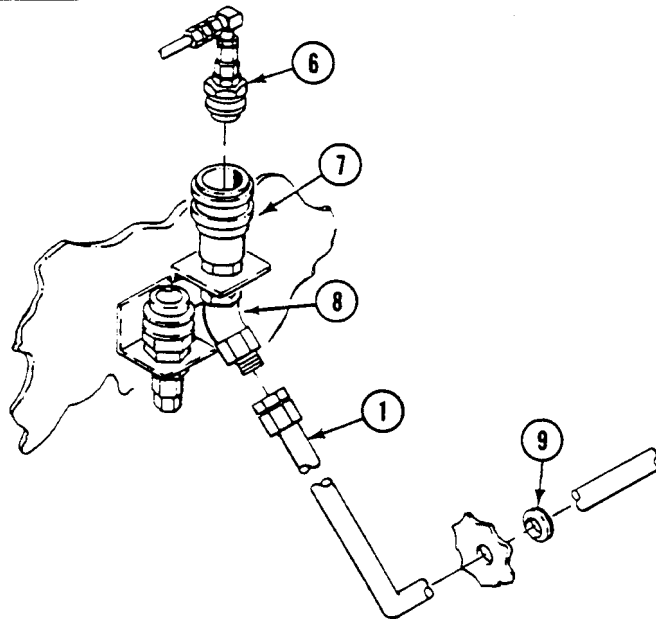

REPLACE FUEL SUPPLY HOSES, TUBES AND FITTINGS (M577A3 AND M1068A3 ONLY)
— Continued

0193 00

20. Remove five screws (10) and clamps (11) that secure hose (1) to weldnuts (12).

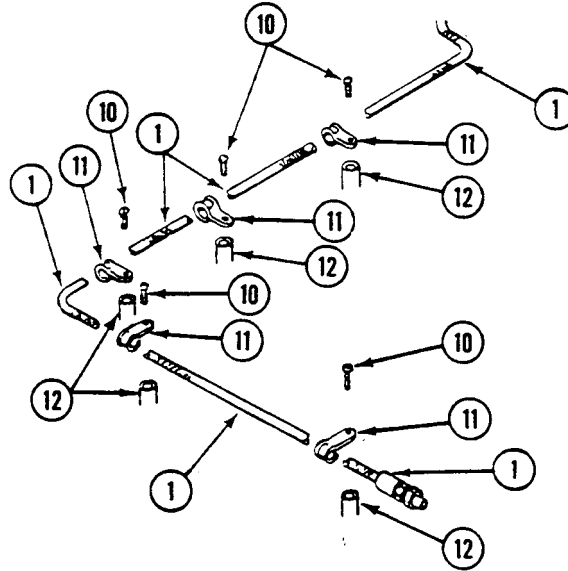

INSTALLATION

1. Apply a thin, even coat of sealing compound to cleaned external pipe threads on fittings.
2. Install new grommet (1) on hose (2). Route hose through hole in bulkhead and install grommet in bulkhead.
3. Install hose (2) on elbow (3). Hold elbow when tightening hose.
4. Install quick disconnect (4) on coupler body (5).

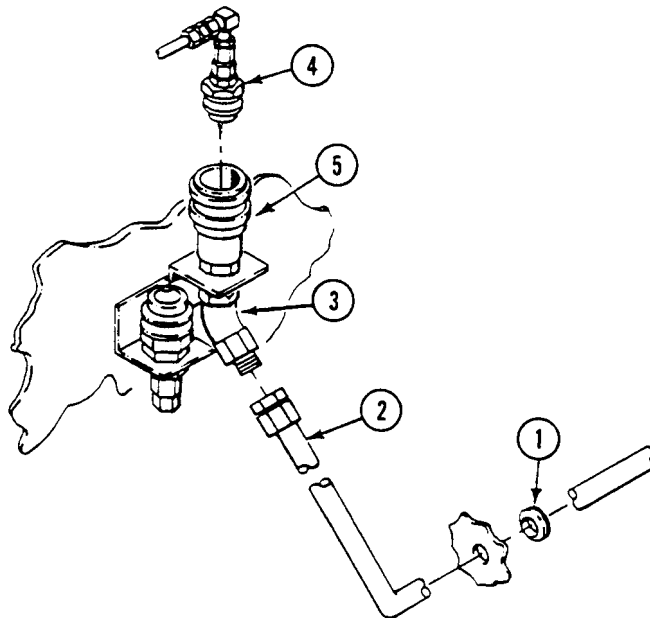

REPLACE FUEL SUPPLY HOSES, TUBES AND FITTINGS (M577A3 AND M1068A3 ONLY)

0193 00

— Continued

5. Install five clamps (6) on hose (2) and secure to weldnuts (7) with screws (8).

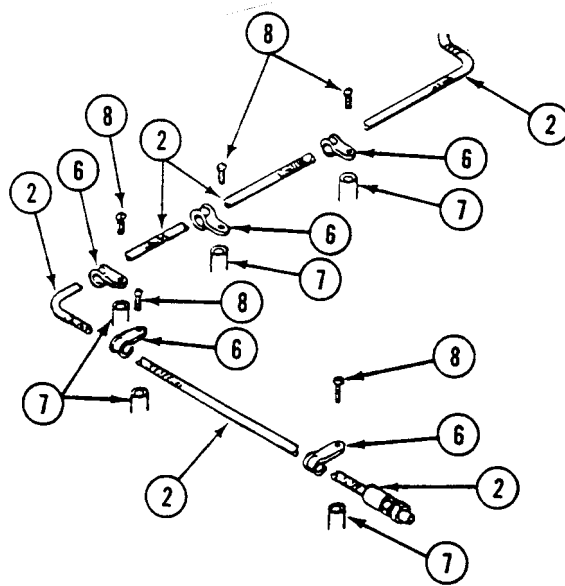

6. Install nipple (9) in tube (10).
7. Install shutoff valve (11) on nipple (9) with arrow pointing toward front of carrier.
8. Install adapter (12) in shutoff valve (11).
9. Connect hose (2) to adapter (12).

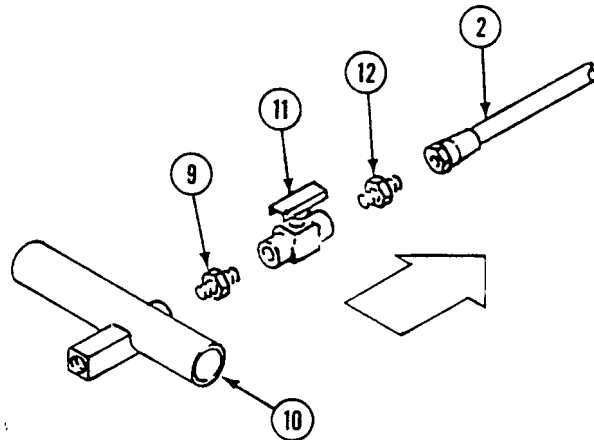

10. Connect two hoses (1) to two fuel tanks (2) and elbows (3) with four clamps (4).
11. Connect hose (5) to tubes (6) and (7) with two clamps (8).
12. Secure elbow (3) to weldnut (9) with clamp (10), new lockwasher (11), and screw (12).
13. Connect hose (13) to elbow (3) and tube (7) with two clamps (14).

REPLACE FUEL SUPPLY HOSES, TUBES AND FITTINGS (M577A3 AND M1068A3 ONLY)

0193 00

— Continued

14. Connect hose (15) to elbow (3) and tube (6) with two clamps (16).
15. Connect four hose assemblies (17) to two elbows (3).
16. Install four nipples (18) in two fuel tanks (2).
17. Connect four hose assemblies (17) to four nipples (18).
18. Install four hose assemblies (17) on four weldnuts (19). Secure with four clamps (20), new lockwashers (21), and screws (22).
19. Install bushing (23), nipple (24), draincock (25), and plug (26) on tube (6).

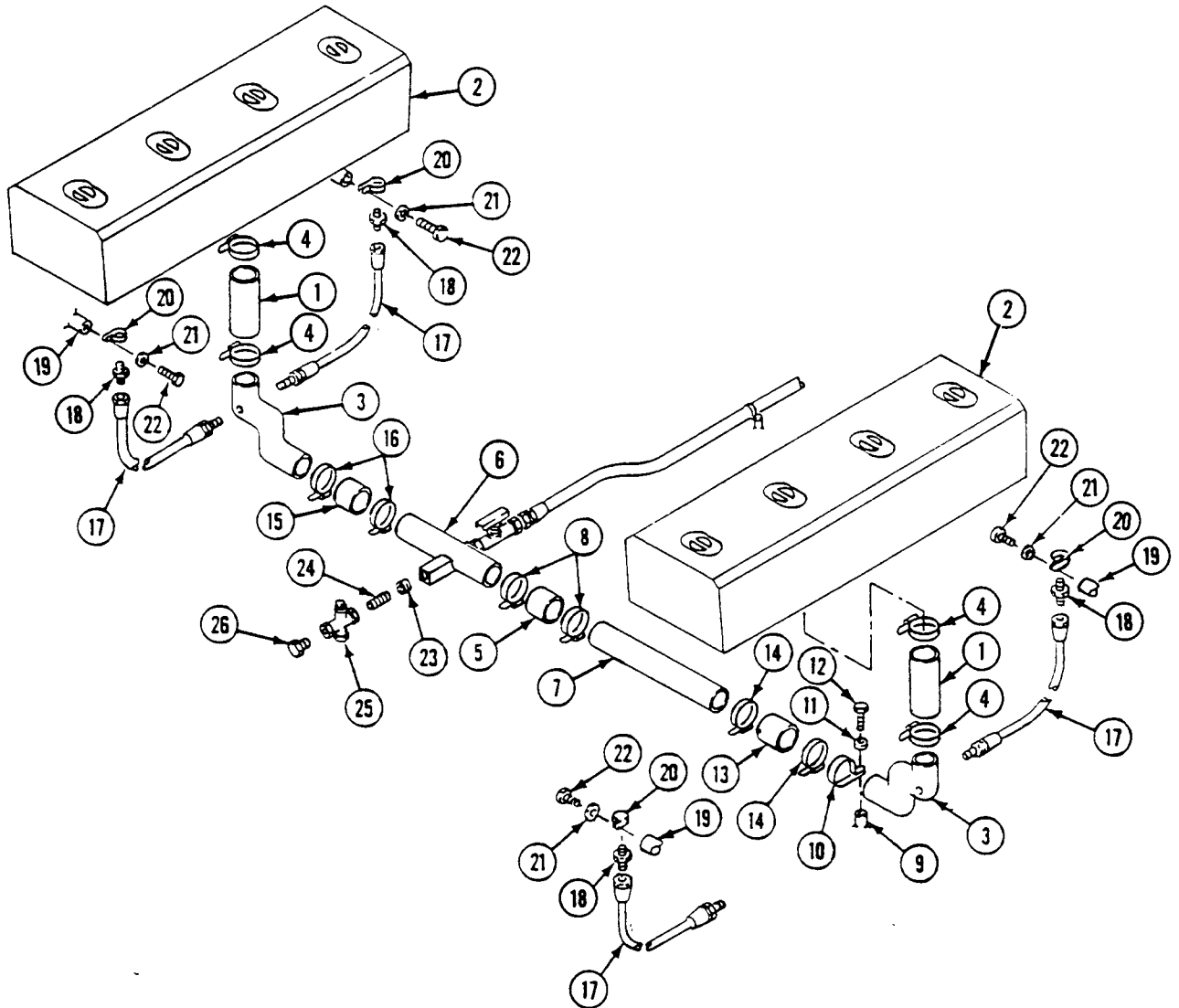

20. Install shutoff valve (1) on nipple (2).
21. Install nipple (2) in tube (3).
22. Install four clamps (4) on two elbows (5) and tubes (3) and (6). Secure four ground leads (7) to clamps (4) with four screws (8), new lockwashers (9), and new locknuts (10).

REPLACE FUEL SUPPLY HOSES, TUBES AND FITTINGS (M577A3 AND M1068A3 ONLY)**0193 00****— Continued**

23. Install leads (7), two elbows (5), and two tubes (3) and (6) on four weldnuts (11). Secure with four clamps (12), new lockwashers (13), and screws (14).
24. Connect personnel heater fuel hose (15) to shutoff valve (1).

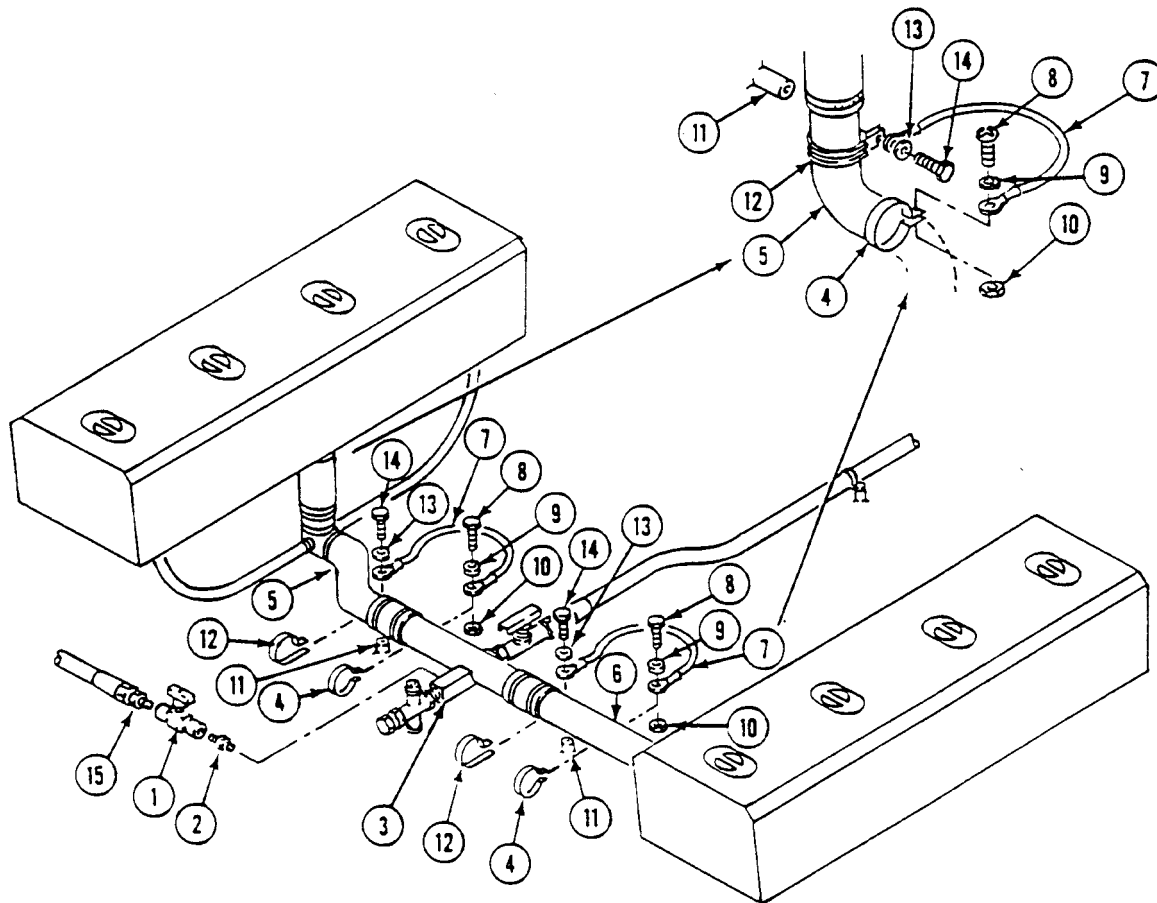
**FOLLOW-THROUGH STEPS**

1. Fill fuel tank (see your -10).
2. Connect battery ground lead (WP 0338 00).
3. Start engine (see your -10). Check for leaks.
4. Stop engine (see your -10).
5. Install power plant rear access panel (WP 0439 00).
6. Install rear compartment floor plates (WP 0539 00) or (WP 0544 00).
7. Start engine (see your -10).
8. Raise and lock ramp (see your -10).
9. Stop engine (see your -10).

END OF TASK

REPLACE FUEL SUPPLY HOSES, TUBES, AND FITTINGS (M1064A3 ONLY)

0194 00

THIS WORK PACKAGE COVERS:

Removal (page 0194 00-2).
 Installation (page 0194 00-9).

INITIAL SETUP:

Maintenance Level

Unit

References

See your -10

Tools and Special Tools

General Mechanic's Tool Kit (WP 0926 00, Item 65)

Equipment Condition

Materials/Parts

Calking compound (WP 0928 00, Item 14)

Sealing compound (WP 0928 00, Item 54)

Grommet

Lockwasher (6)

Strap (2)

Ramp lowered (see your -10)

Engine stopped (see your -10)

Carrier blocked (see your -10)

Power plant rear access panels removed (see your -10)

Battery ground strap disconnected (WP 0337 00)

Fuel tanks drained (WP 0177 00)

Heater duct removed (WP 0706 00)

Rear floor plates removed (WP 0543 00)

Personnel Required

Unit Mechanic

REMOVAL

1. Locate quick disconnect (1) on rear bulkhead inside power plant.
2. Separate quick disconnect nose (1) from quick disconnect body (2).
3. Remove fuel supply hose (6) from elbow (5).
4. Remove fuel supply hose (6) and grommet (7) from bulkhead. Discard grommet.
5. Remove elbow (5) from coupler body (2).
6. Remove nut (4) and coupler body (2) from bracket (3).

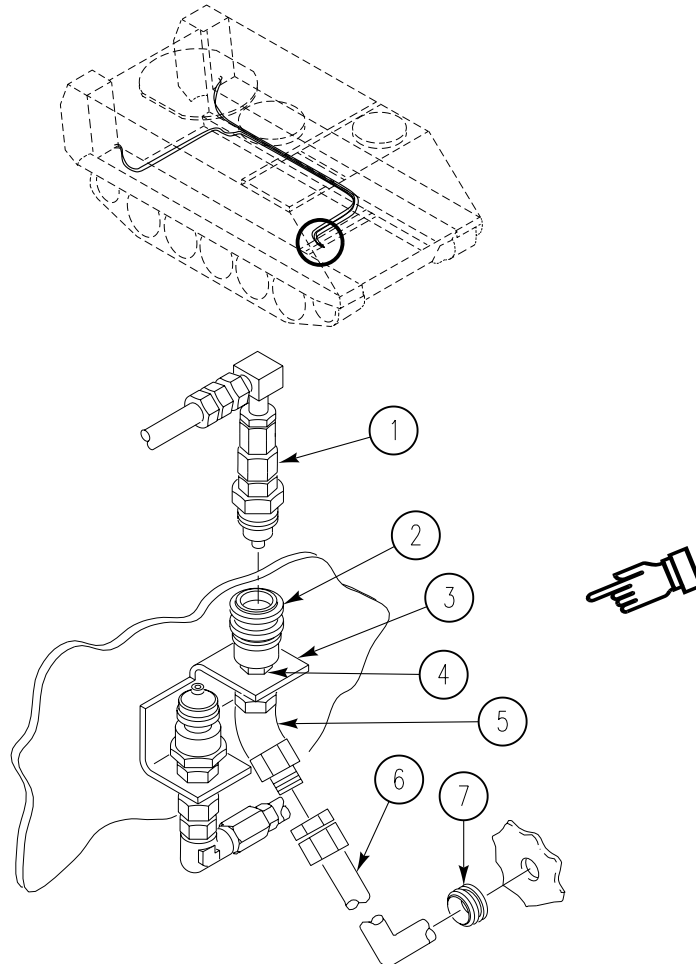

7. Remove four screws (19), lockwashers (18), and eight clamps (17) from weldnuts. Discard lockwashers.
8. Remove four hose clamps (17) from fuel supply hose (16).
9. Remove floor plate screw (14) and washer (15) from guard (12).
10. Remove screw (21), washer (20), nut (13), and guard (12).
11. Disconnect fuel supply hose (16) from adapter (8).
12. Remove adapter (8) from tee (7).

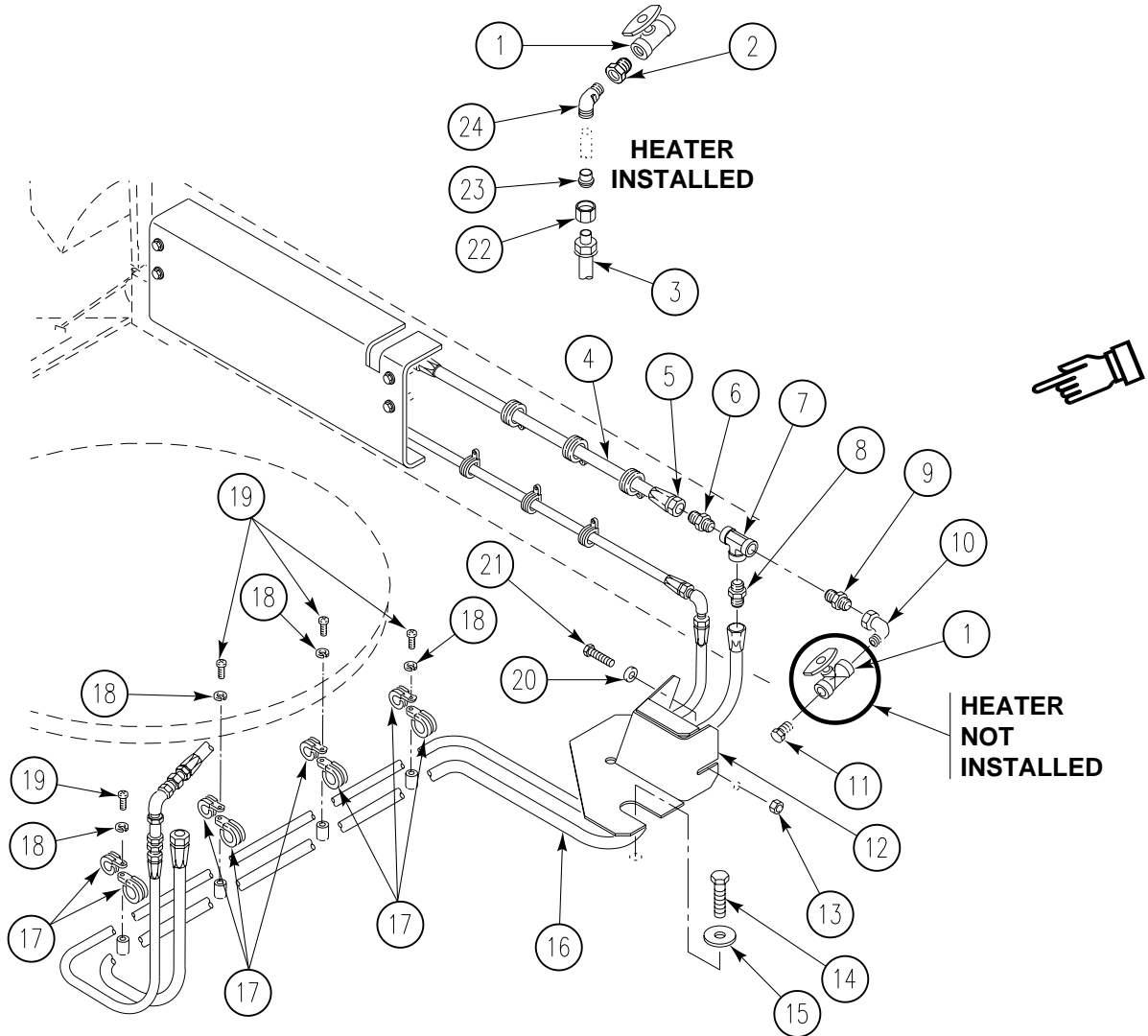

NOTE

If crew compartment heater is installed, complete Steps 13 - 15 to remove heater fuel supply hose. Skip Step 16.

If heater is not installed, do Step 16. Skip Steps 13 - 15.

13. Disconnect crew compartment heater hose (3) from elbow (24) with sleeve (23) and nut (22) attached.
14. Remove elbow (24) from bushing (2).
15. Remove bushing (2) from valve (1).
16. Remove plug (11) from valve (1).
17. Remove valve (1) from elbow (10).
18. Remove elbow (10) from nipple (9).
19. Remove nipple (9) from tee (7).
20. Remove fuel supply tube (4) from adapter (5).
21. Remove adapter (5) and nipple (6) from tee (7).

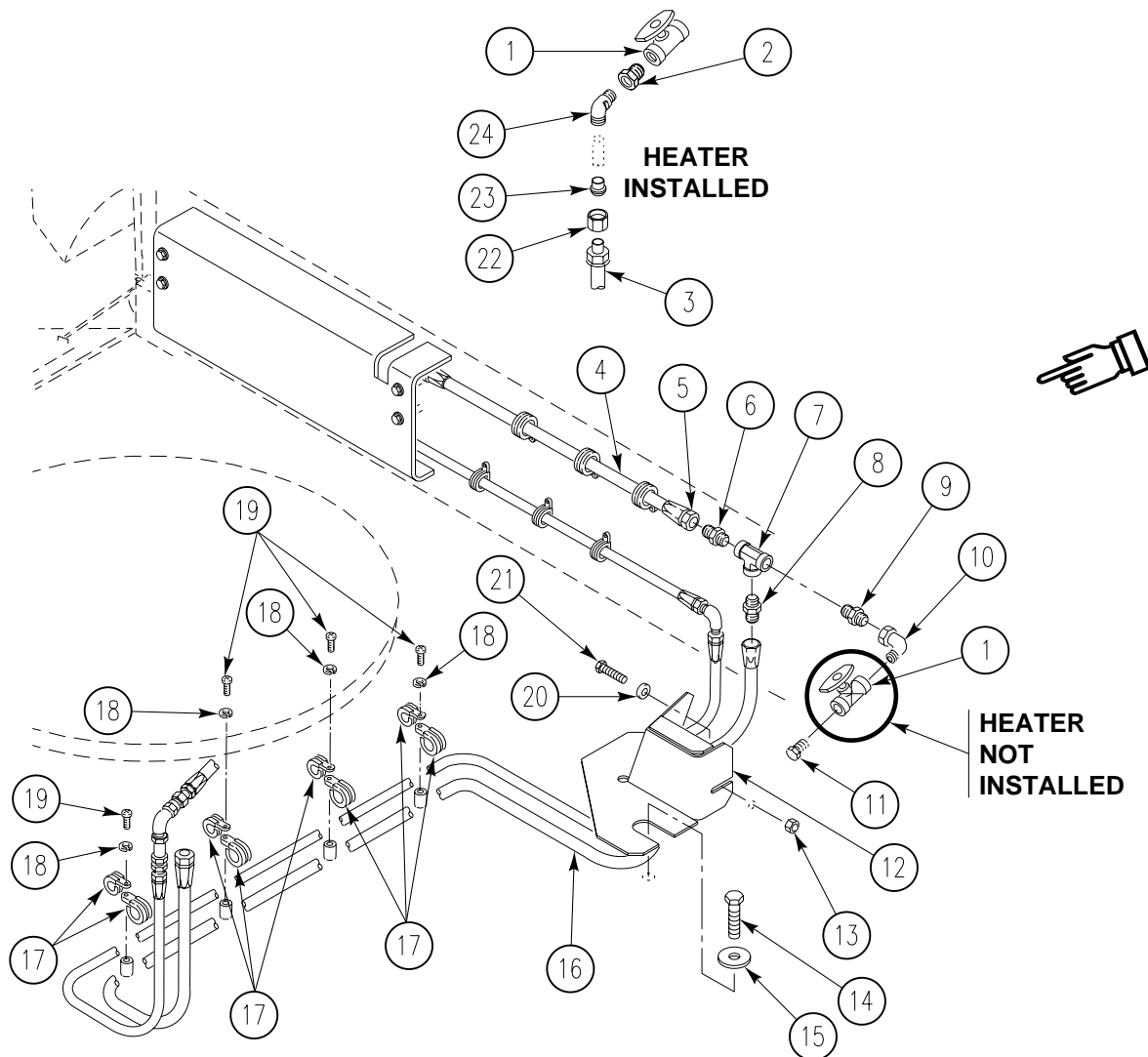

22. Remove three screws (1), lockwashers (2), and six clamps (3) from weldnuts. Discard lockwashers.
23. Remove clamps (3) from fuel supply tube (4).
24. Remove four screws (5), lockwashers (6), and guard (7) from sponson. Discard lockwashers.
25. Disconnect fuel supply tube (4) from adapter (8).
26. Remove adapter (8) from fuel supply hose (9).
27. Remove fuel supply hose (9) from adapter (10).
28. Remove adapter (10) from tee (11).

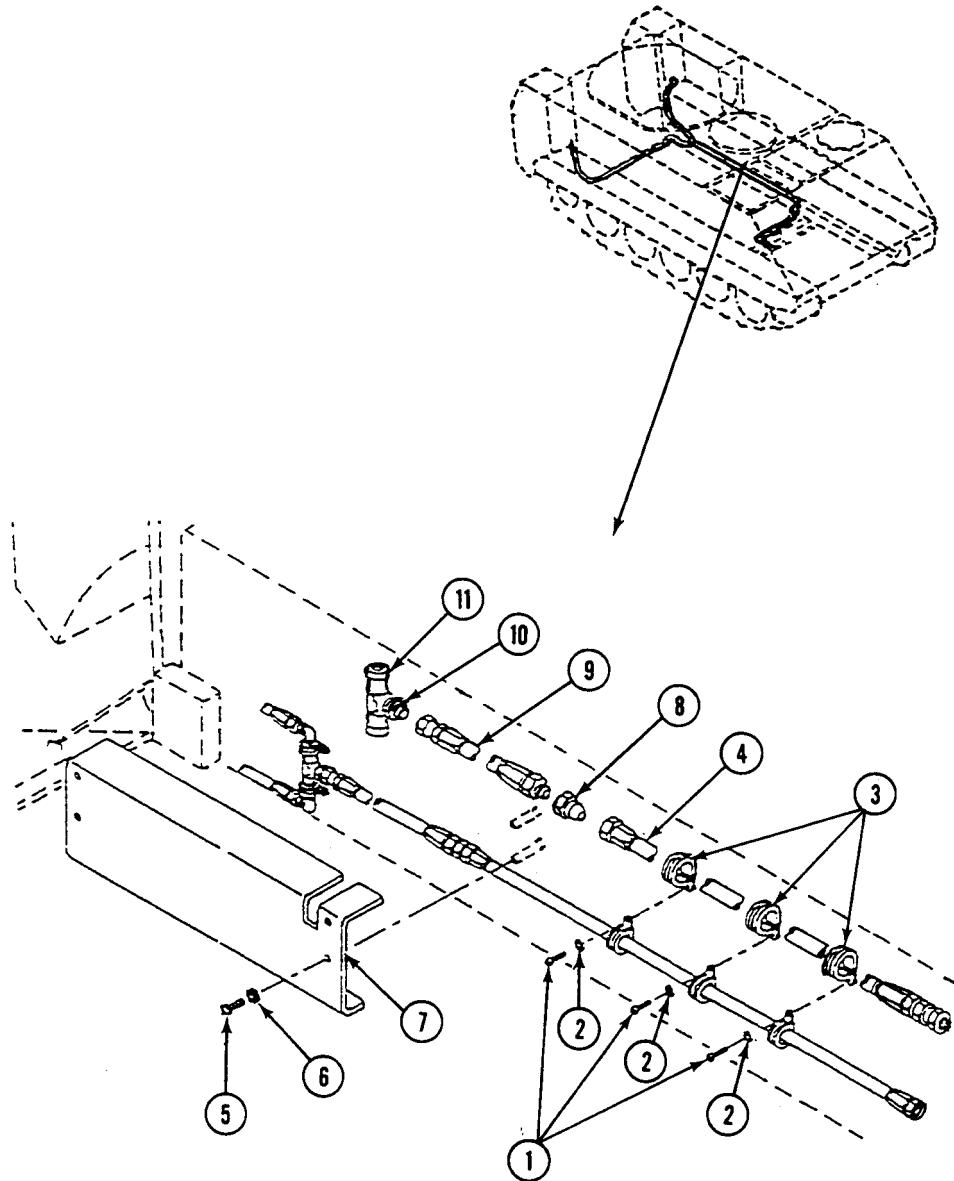

29. Disconnect two fuel supply hoses (11) and (17) from two elbows (12).
30. Remove two screws (16) and lockwashers (15) from clamps (13). Discard lockwashers.
31. Remove two clamps (13) and two elbows (12) from tee (14).

NOTE

The left external fuel tank outlet valve is secured to its mounting block by TWO clamps, washers, and screws. The right external fuel tank outlet valve is secured with two straps to bilge tube and return hose.

32. Remove two screws (26), washers (27), clamps (7), and left external fuel tank outlet valve (8) from mounting block (6).
- 33. Remove two straps (22) securing both fuel hoses to bilge tube (21). Discard straps.
34. Remove hoses (11) and (17) from adapters (10).
35. Remove adapters (10) from adapters (9).
36. Remove adapters (9) from valves (8) and (23).

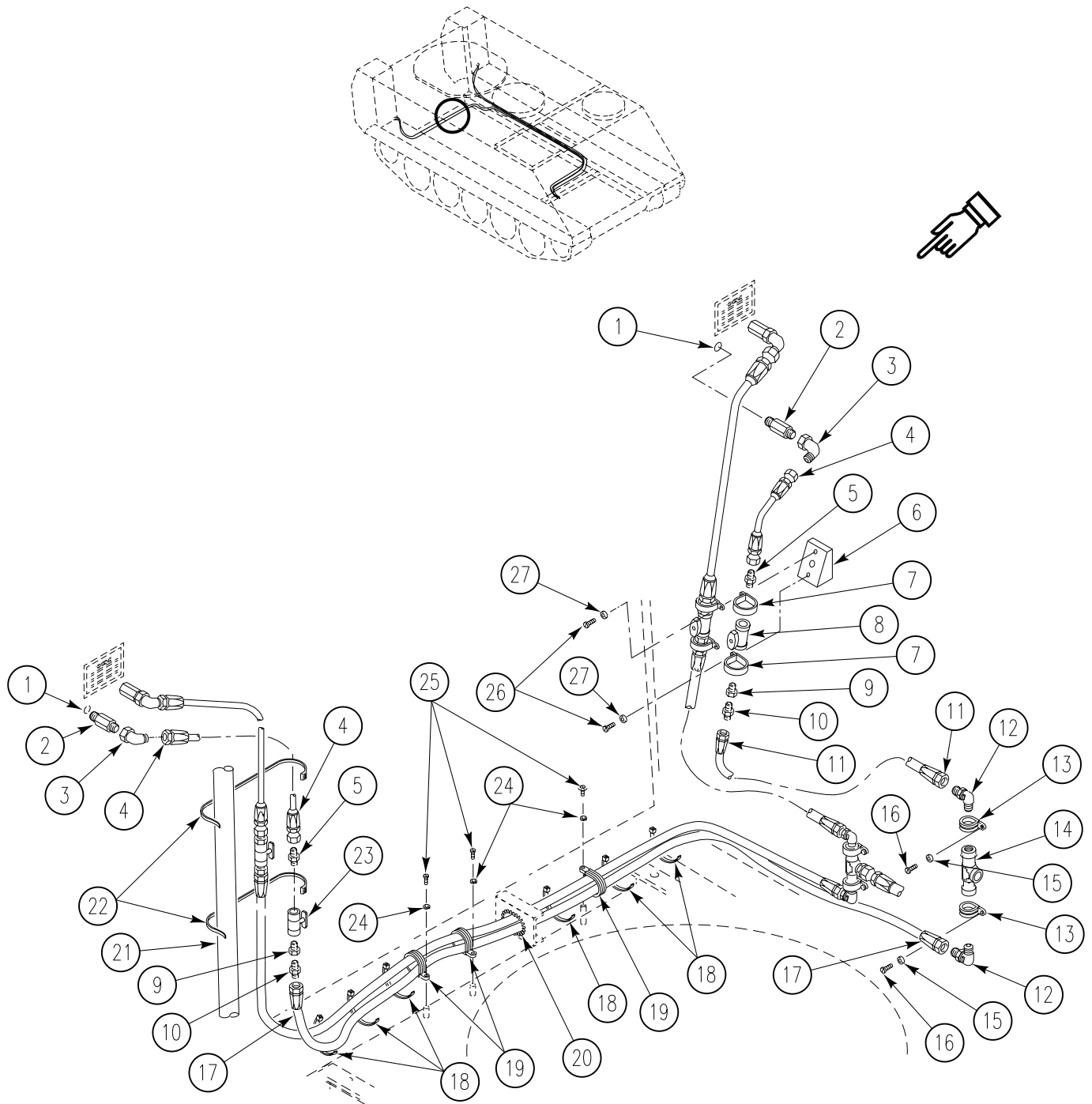

37. Remove hoses (4) from adapters (5).
38. Remove adapters (5) from valves (8) and (23).
39. Remove hoses (4) from elbows (3).
40. Remove elbows (3) from adapters (2).
41. Remove adapters (2) from fuel tanks (1).
42. Remove three screws (25), lockwashers (24), and clamps (19) securing right external fuel tank hose to weldnuts. Discard lockwashers.
43. Remove three clamps (19) and straps (18) from right external fuel tank hose, wiring harness, and bilge pump tube.

NOTE

Replace grommet only if necessary.

44. Remove fuel supply hose (17) from grommet (20).

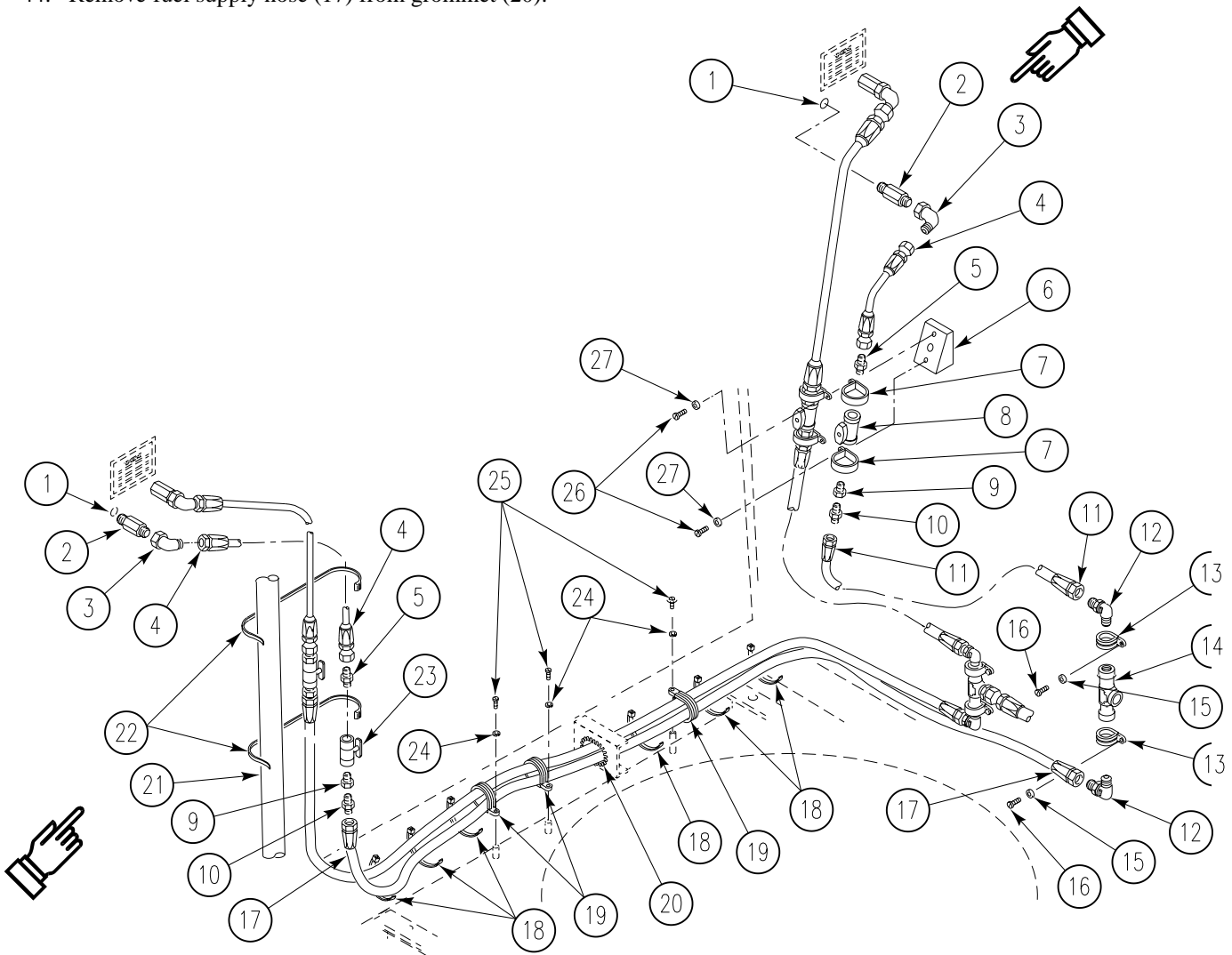

INSTALLATION

NOTE

To install left external fuel tank fuel supply hoses and fittings, do Steps 1 - 10. To install right external fuel tank fuel supply hoses and fittings, do Steps 11 - 23.

The left external fuel tank outlet valve is secured to its mounting block by TWO clamps, washers, and screws. The right external fuel tank outlet valve is secured to the bilge tube and fuel return hose with two straps.

1. Apply sealing compound to external threads of adapter (1) and elbow (2).
2. Install adapter (1) on left external fuel tank (3). Install elbow (2) on adapter (1).
3. Apply calking compound to space around adapter (1) on rear hull plate.
4. Install hose (4) on elbow (2).

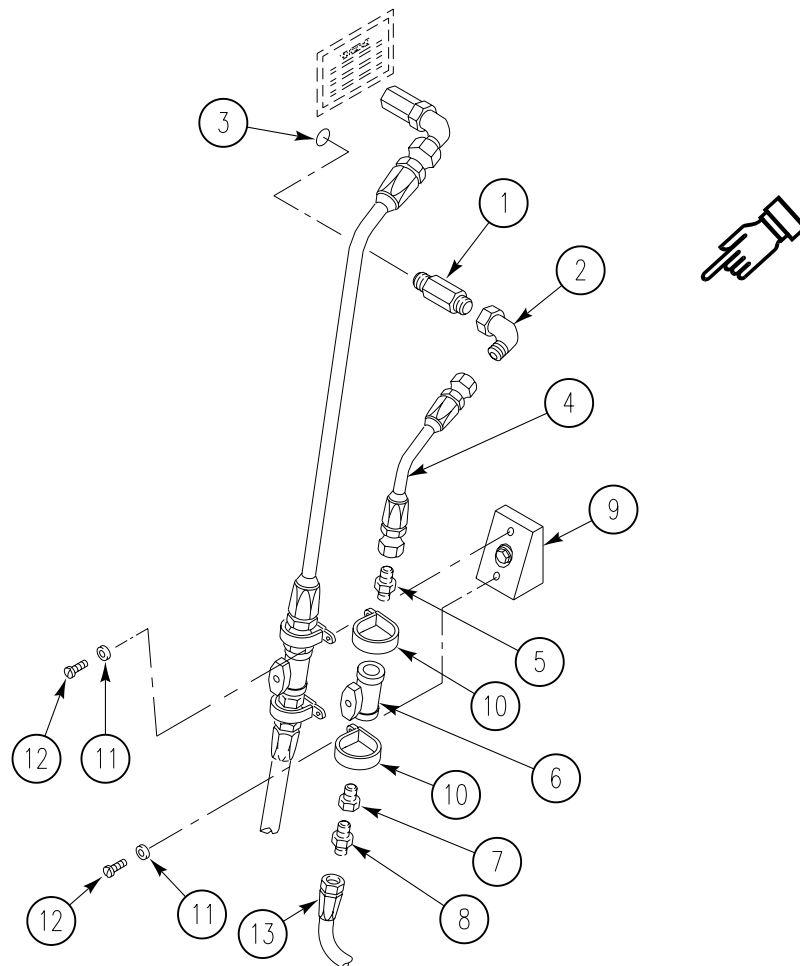

5. Apply sealing compound to external threads of adapter (5). Install adapter (5) on valve (6).
6. Install hose (4) on adapter (5).
7. Apply sealing compound on external threads of adapters (7) and (8).
8. Install adapter (7) on valve (6). Install adapter (8) on adapter (7).
9. Secure valve (6) to mounting block (9) with two clamps (10), washers (11), and screws (12).
10. Connect fuel supply hose (13) to adapter (8).

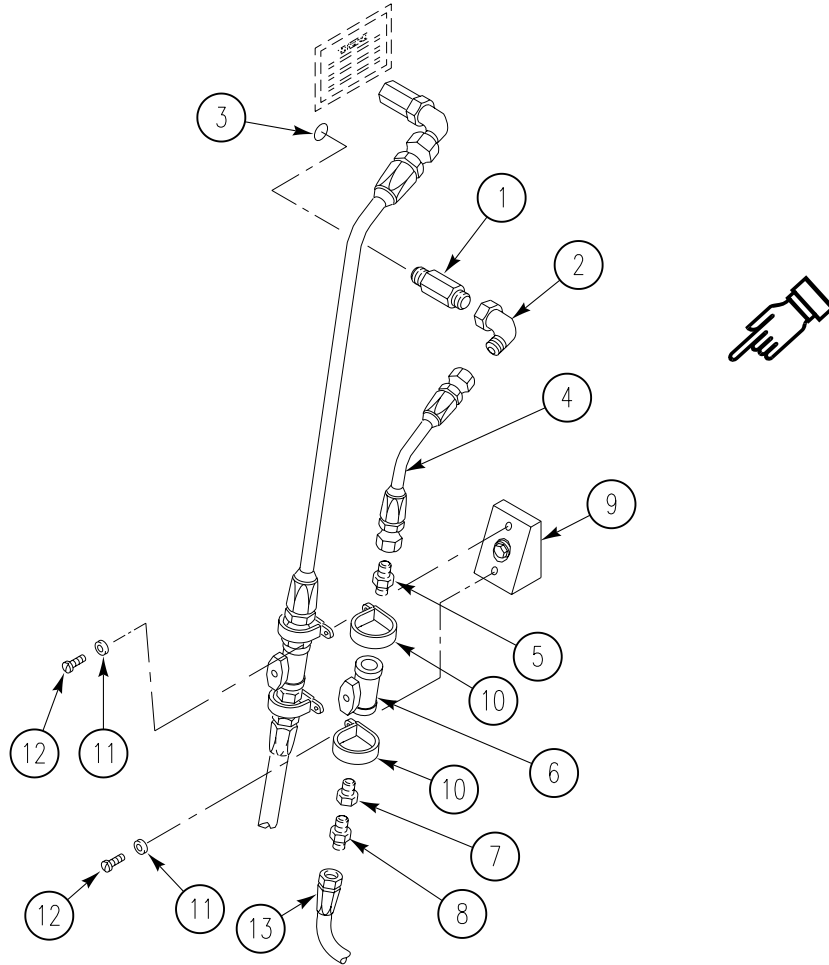

NOTE

Apply adhesive to new grommet before installing.

11. Install fuel supply hose (15) through grommet (18).
12. Install three clamps (17) and straps (16) as required on fuel hoses, wiring harness, and bilge pump tube.
13. Install three screws (7), new lockwashers (6), and clamps (17) on weldnuts.
14. Apply sealing compound to external threads of adapter (23) and elbow (22).
15. Install adapter (23) on right external fuel tank (1).
16. Install elbow (22) on adapter (23).
17. Apply calking compound to space around adapter (23) on rear hull plate.
18. Install hose (21) on elbow (22).
19. Apply sealing compound to external threads of adapter (2). Install adapter (2) on valve (3).
20. Install hose (21) on adapter (2).

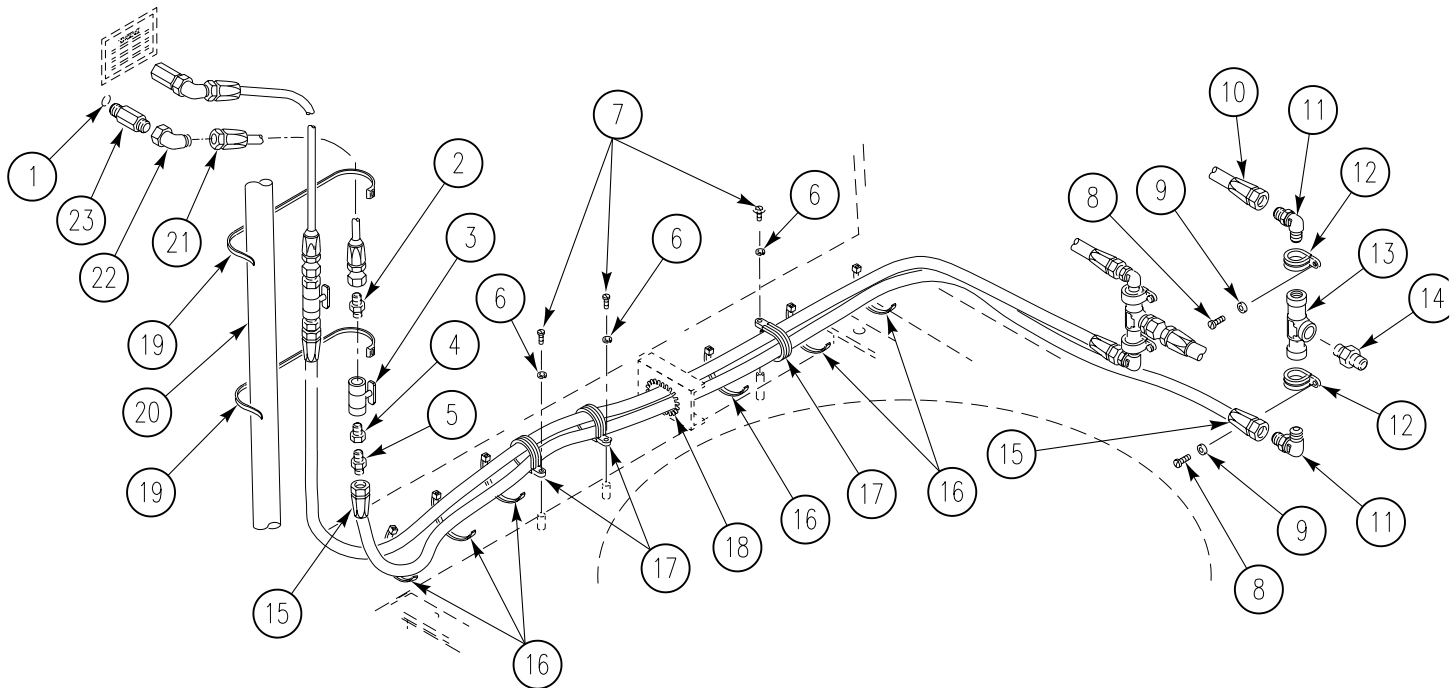

21. Apply sealing compound to external threads of adapters (4) and (5). Install adapter (4) on valve (3) and adapter (5) on adapter (4).
22. Install hose (15) on adapter (5).
23. Secure valve (3) with two new straps (19) to return fuel hose and bilge tube (20).
24. Apply sealing compound to external threads of two elbows (11). Install two elbows (11) and clamps (12) on tee (13).
25. Install two screws (8), new lockwashers (9), clamps (12), and tee (13) on weldnuts.
26. Connect two fuel supply hoses (10) and (15) to two elbows (11).
27. Apply sealing compound to external threads of adapter (14). Install adapter on tee (13).

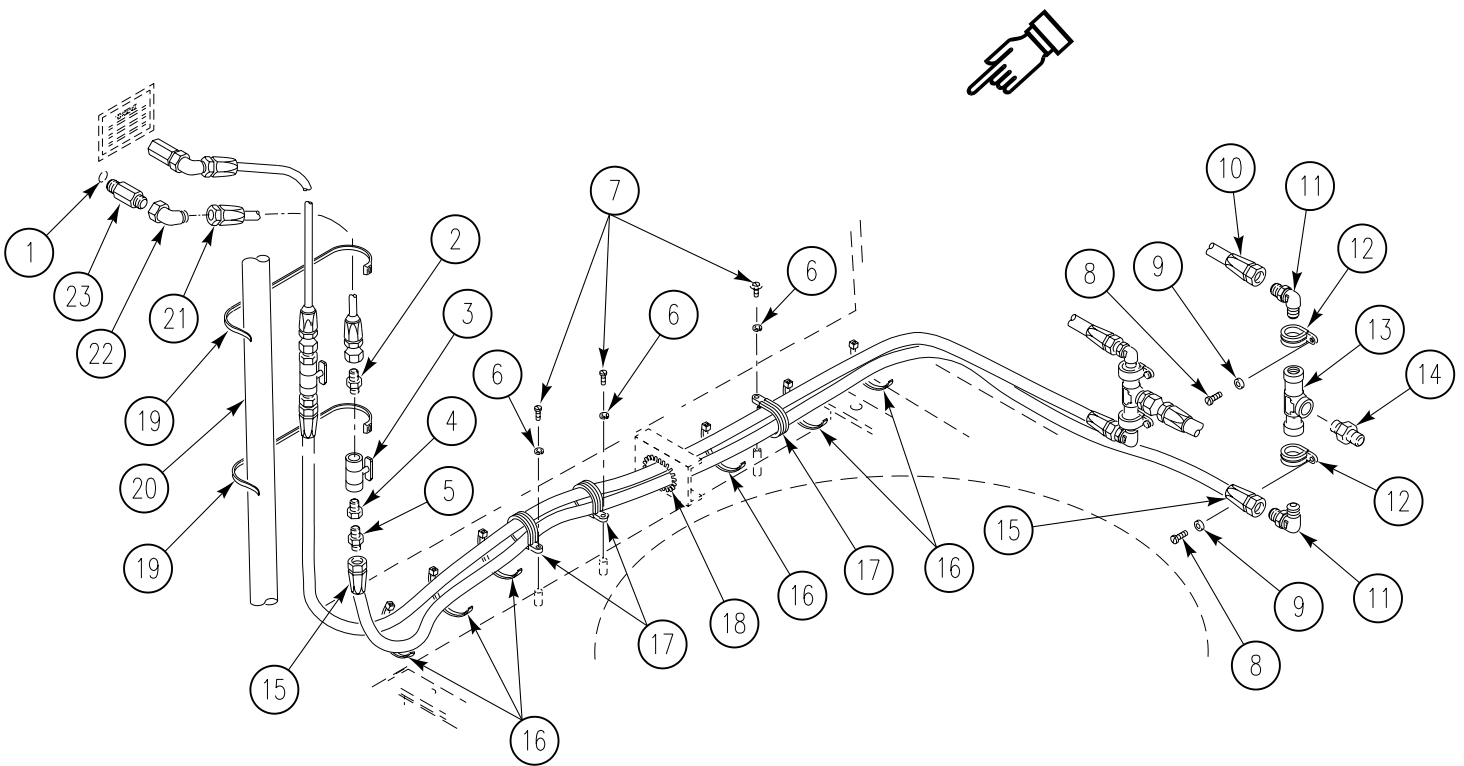

28. Connect fuel supply hose (1) to adapter (2).
29. Apply sealing compound to external threads of adapter (3). Install adapter (3) on fuel supply hose (1).
30. Connect fuel supply tube (4) to adapter (3).
31. Install guard (5), four new lockwashers (6) and screws (7) on sponson.
32. Install three clamps (8) on fuel supply tube (4).

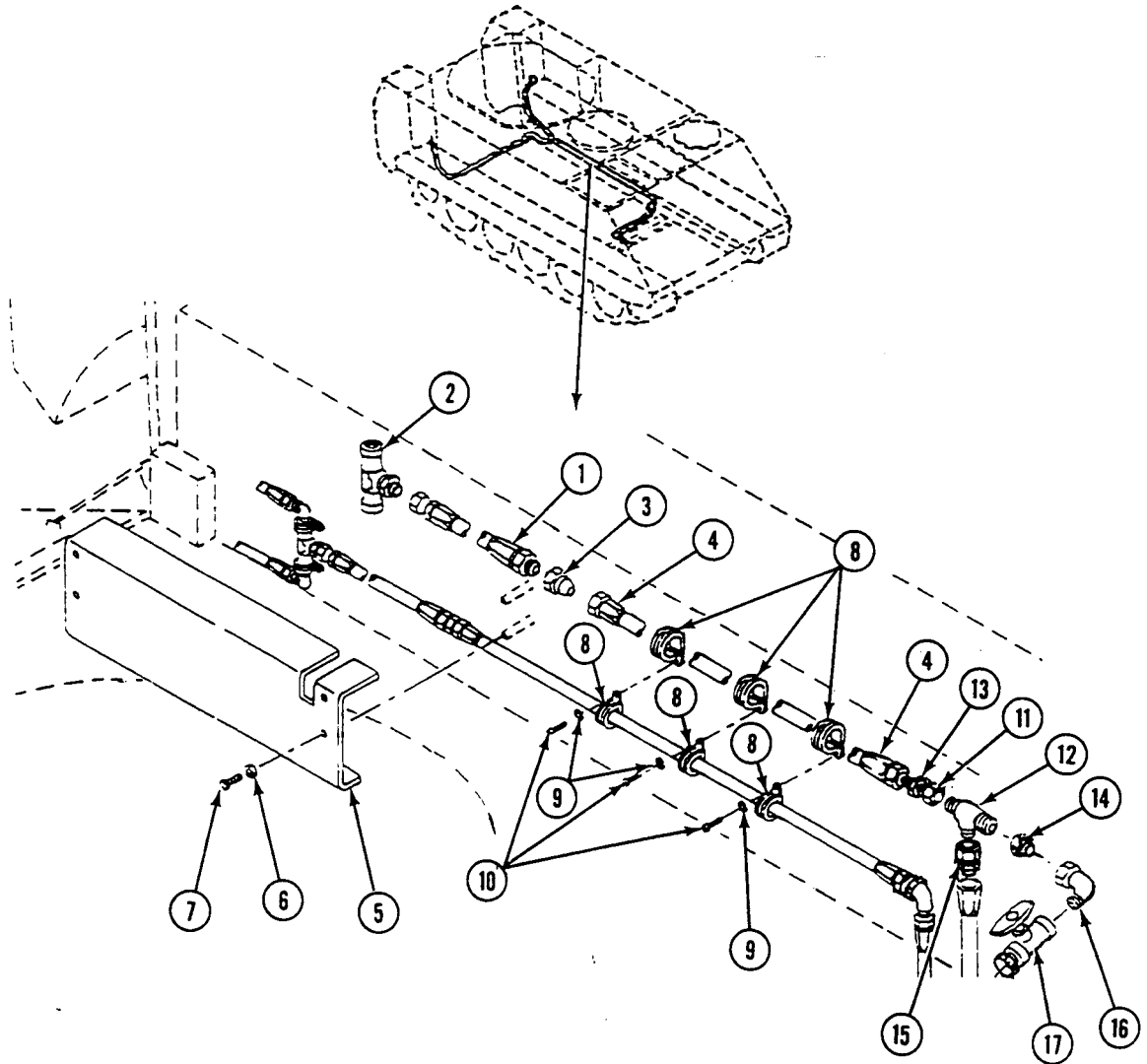

33. Install six clamps (8), fuel supply tube (4), three new lockwashers (9) and screws (10) on weldnuts.
34. Apply sealing compound to external threads of nipple (11) and tee (12). Install nipple (11) on tee (12).
35. Apply sealing compound to external threads on adapter (13). Install adapter (13) on nipple (11).
36. Connect fuel supply tube (4) to adapter (13).
37. Install nipple (14) and adapter (15) on tee (12).
38. Install elbow (16) on nipple (14).
39. Install valve (17) on elbow (16).

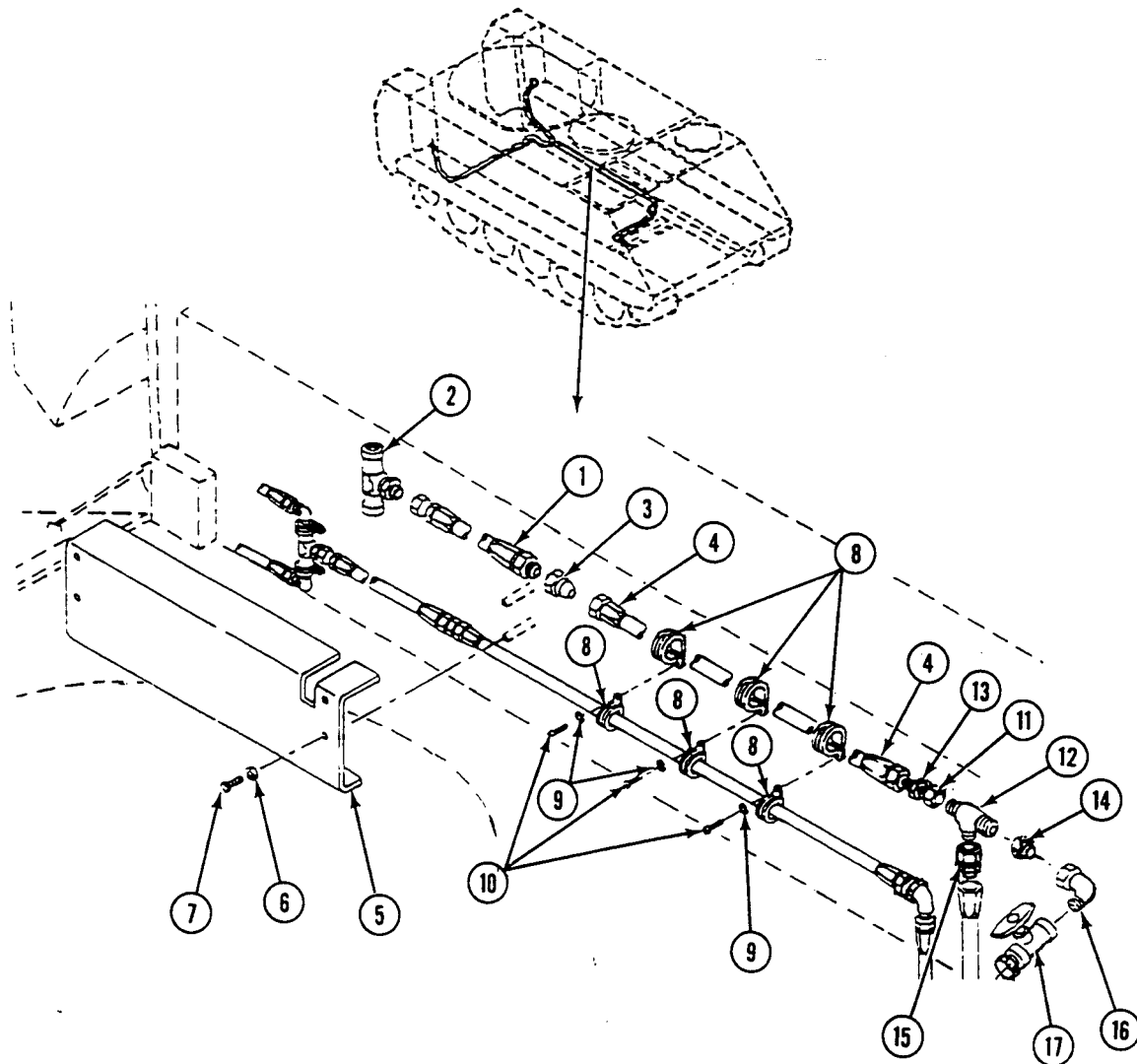

NOTE

If crew compartment heater is installed, do Steps 40 - 42. Skip Step 43. If heater is not installed, do Step 43. Skip Steps 40 - 42.

40. Install bushing (2) in valve (1).
41. Install elbow (3) in bushing (2).
42. Install crew compartment heater fuel supply hose (6) on elbow (3). Secure with sleeve (4) and nut (5).
43. Install plug (7) on valve (1).
44. Install fuel supply hose (8) on adapter (18).
45. Install four clamps (12) on fuel supply hose (8).
46. Install eight clamps (12), four new lockwashers (13), screws (14), and fuel supply hose (8) on weldnuts.

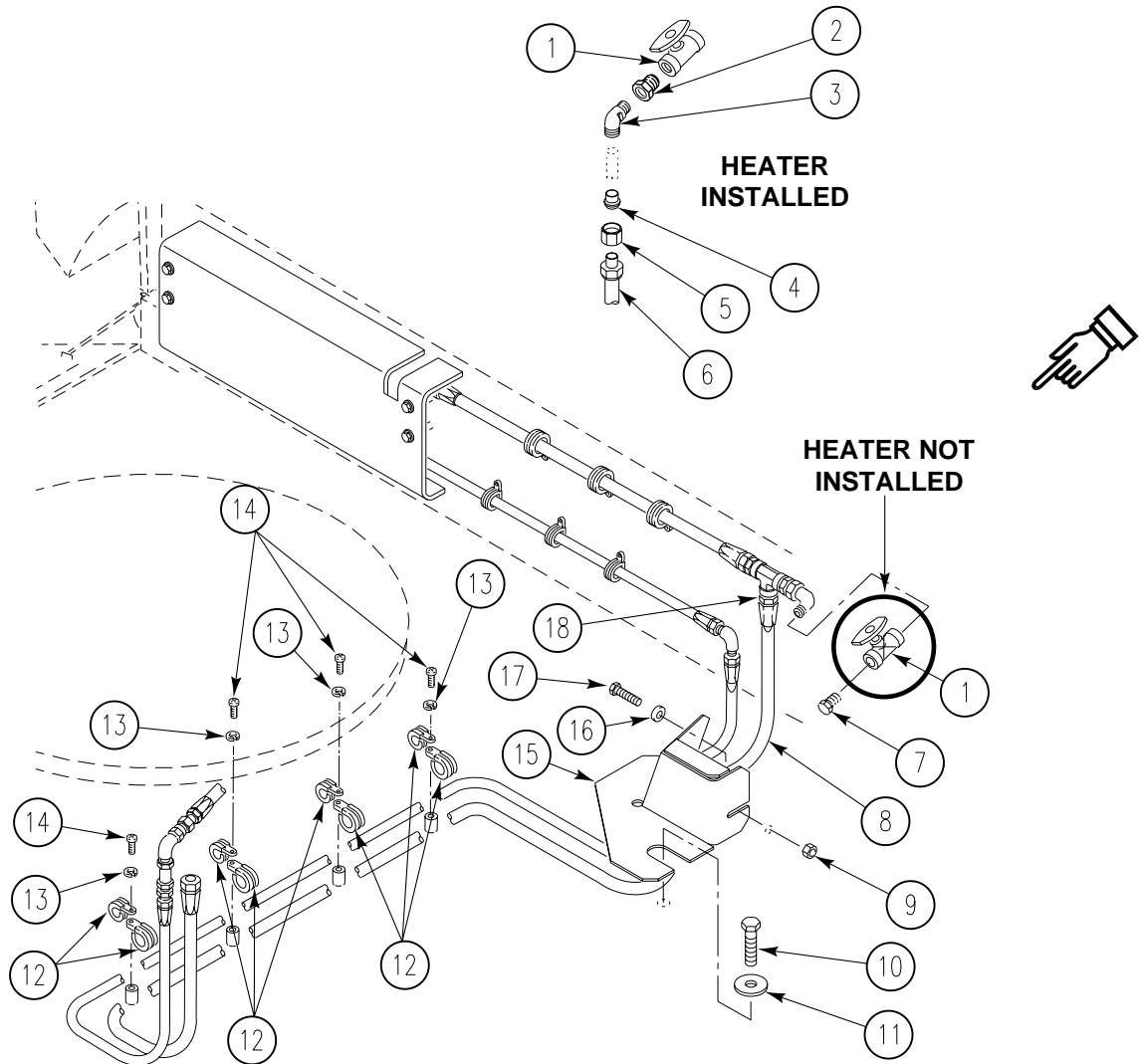

- 47. Install guard (15), washer (16), screw (17) and nut(9) .
- 48. Install floor plate screw (10) and washer (11) to secure guard (15).

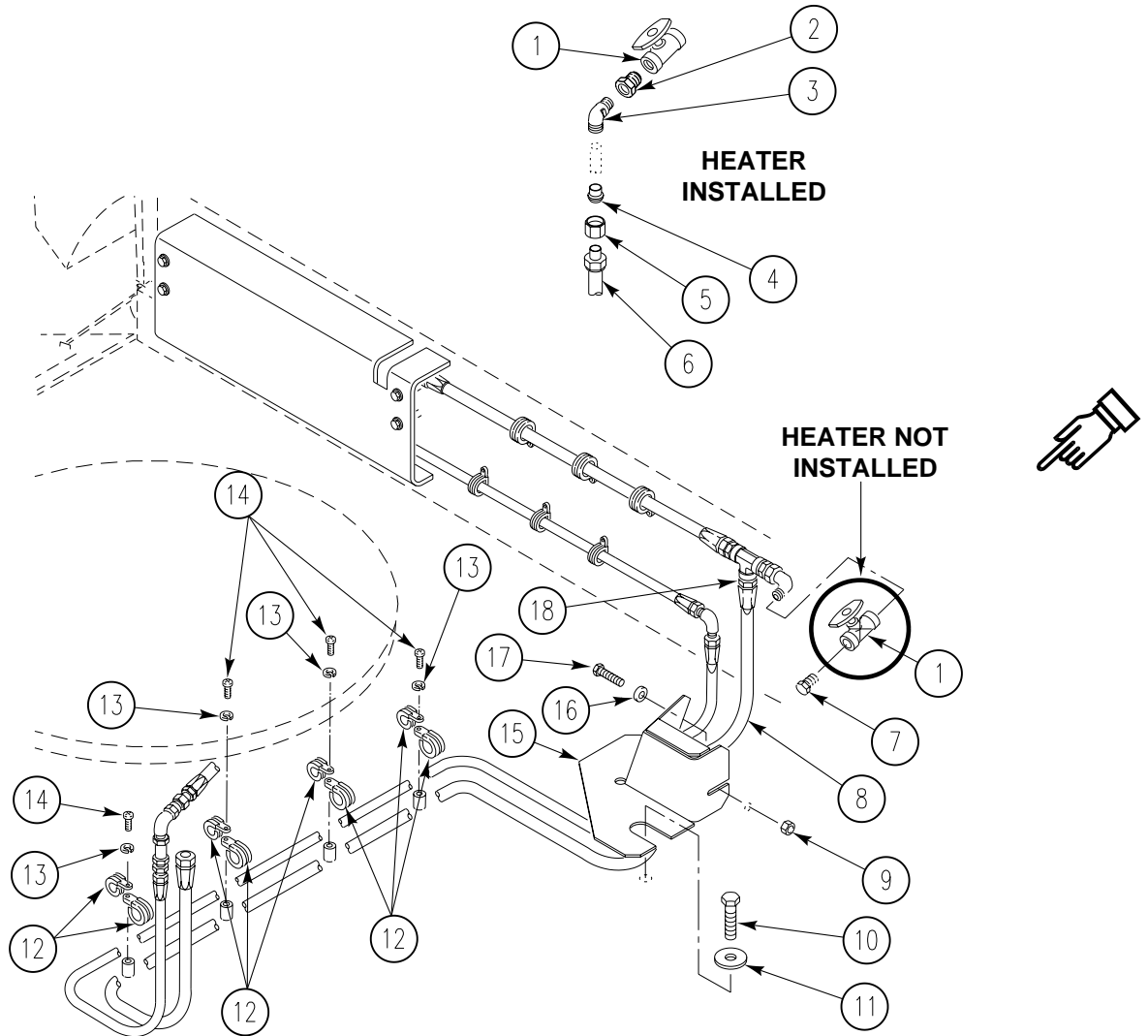

49. Install quick disconnect coupler body (2) and nut (4) in bracket (3).
50. Install elbow (5) on quick disconnect coupler body (2).
51. Install new grommet (7) on fuel supply hose (6). Route hose through hole in bulkhead and fit grommet into bulkhead.
52. Connect fuel supply hose (6) to elbow (5). Hold elbow when tightening hose.
53. Connect quick disconnect nose (1) to quick disconnect coupler body (2).

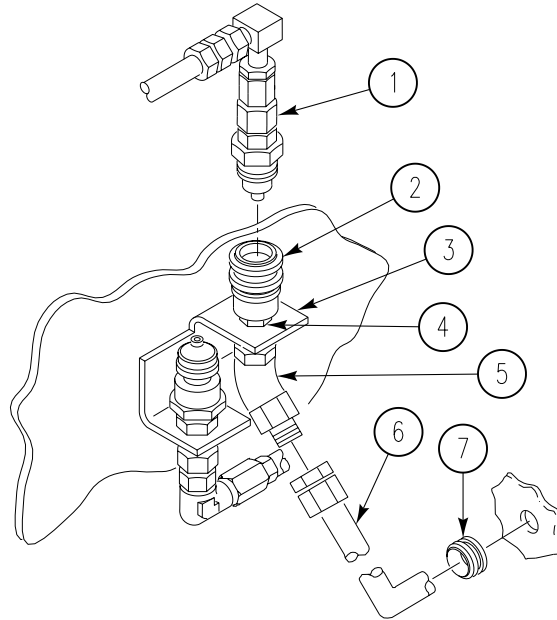

FOLLOW-THROUGH STEPS

1. Fill fuel tanks (see your -10).
2. Connect battery ground strap (WP 0337 00).
3. Start engine (see your -10).
4. Check for leaks in fuel lines.
5. Stop engine (see your -10).
6. Install power plant rear access panels (see your -10).
7. Install rear floor plates (WP 0543 00).
8. Install heater duct (WP 0706 00).
9. Start engine (see your -10).
10. Raise and lock ramp (see your -10).
11. Stop engine (see your -10).

END OF TASK

REPLACE FUEL RETURN HOSES, TUBES, AND FITTINGS (M113A3, M1059A3, AND M58 ONLY)

0195 00

THIS WORK PACKAGE COVERS:

Removal (page 0195 00-1).
 Installation (page 0195 00-8).

INITIAL SETUP:

Maintenance Level

Unit

Tools and Special Tools

General Mechanic's Tool Kit (WP 0926 00, Item 65)

Materials/Parts

Caulking compound (WP 0928 00, Item 14)

Sealing compound (WP 0928 00, Item 56)

Grommet

Locknut

Lockwasher (15)

Strap

Personnel Required

Unit Mechanic

References

See your -10
 TM 3-1040-285-20

Equipment Condition

Engine stopped (see your -10)

Carrier blocked (see your -10)

Ramp lowered (see your -10)

Power plant lower rear access panel removed (see your -10)

Floor plates removed (WP 0539 00), (WP 0542 00), or (WP 0545 00)

Battery ground strap disconnected (WP 0337 00)

Fuel tanks drained (WP 0177 00)

Smoke generator fog oil tank module removed (M1059A3 only) (WP 0753 00)

Smoke generator system removed (M58 only) (TM 3-1040-285-20)

**REPLACE FUEL RETURN HOSES, TUBES, AND FITTINGS (M113A3,
M1059A3, AND M58 ONLY) — Continued**

0195 00

REMOVAL

1. Remove quick disconnect coupler body (1) from quick disconnect coupler nose (2).
2. Remove hose (3) from elbow (4).
3. Remove hose (3) and grommet (5) from bulkhead. Discard grommet.

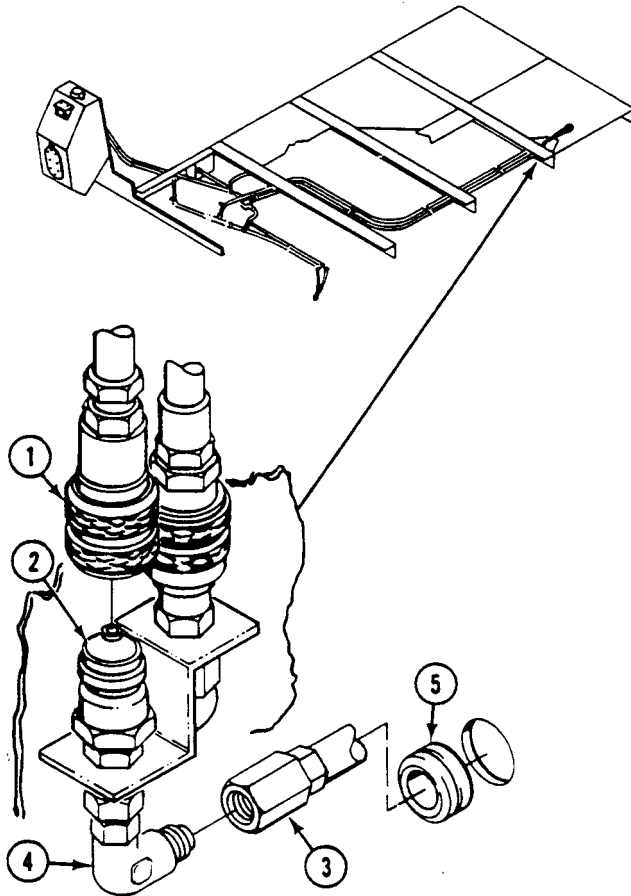

**REPLACE FUEL RETURN HOSES, TUBES, AND FITTINGS (M113A3,
M1059A3, AND M58 ONLY) — Continued**

0195 00

4. Remove five screws (1), lockwashers (2), and clamps (3) from hose (4) and carrier. Discard lockwashers.
5. Remove hose (4) from tee connector (5).

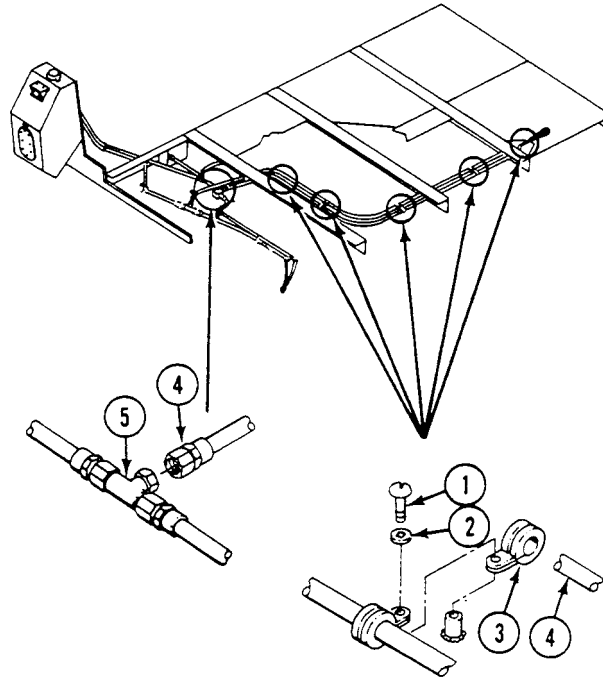

NOTE

Do Steps 6 - 18 for removing left side fuel tank return hoses and fittings. Do Steps 19 - 30 for removing right side fuel tank return hoses and fittings.

6. Remove screw (6), lockwasher (7), and clamp (8) from hose (9) and carrier. Discard lockwasher.
7. Remove tie down strap (10) from two hoses (9) and (11). Discard strap.
8. Remove locknut (12) and screw (13) from guard (14). Discard locknut.
9. Remove screw (15), washer (16), and guard (14) from bulkhead.
10. Remove hose (9) from tee (5).

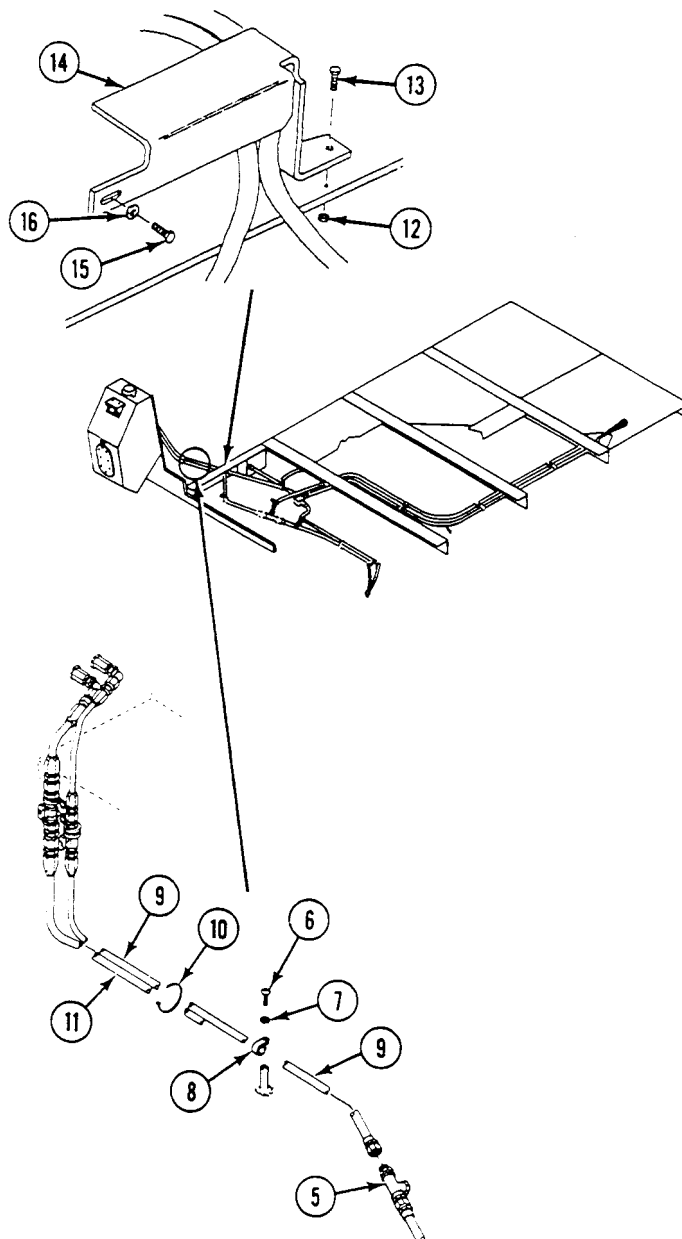

**REPLACE FUEL RETURN HOSES, TUBES, AND FITTINGS (M113A3,
M1059A3, AND M58 ONLY) — Continued**

0195 00

11. Remove screw (1), washer (2), and clamp (3) securing valve (4) to mounting block (5).
12. Remove hose (6) from adapter (7).
13. Remove adapter (7) from valve (4).
14. Remove hose (8) from adapter (9).
15. Remove adapter (9) from valve (4).
16. Remove hose (8) from elbow (10).
17. Remove elbow (10) from adapter (11).
18. Remove adapter (11) from fuel tank (12).

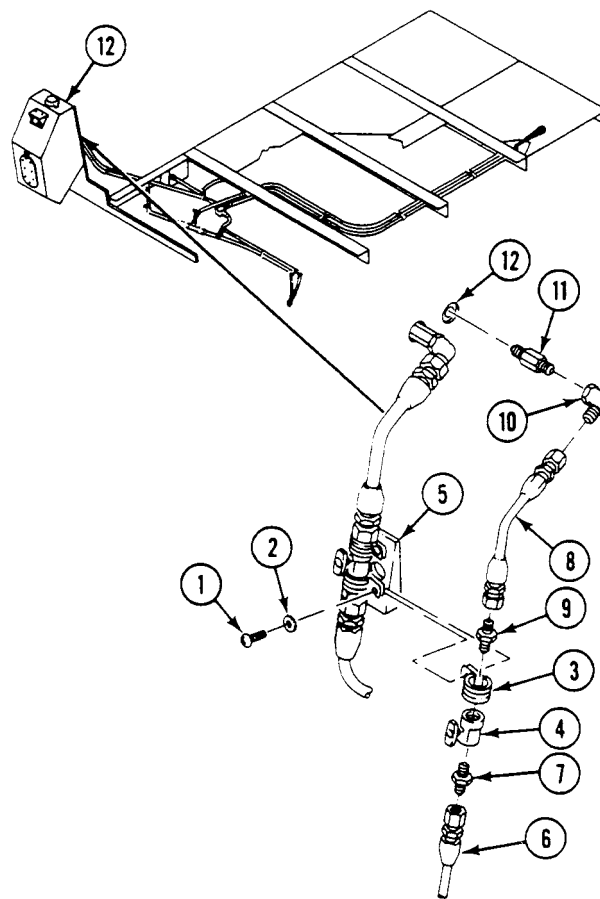

**REPLACE FUEL RETURN HOSES, TUBES, AND FITTINGS (M113A3,
M1059A3, AND M58 ONLY) — Continued**

0195 00

19. Remove three screws (13), lockwashers (14), and clamps (15) from hose (16) and carrier. Discard lockwashers.
20. Remove two tie down straps (17) from two hoses (16) and (18). Discard straps.
21. Remove hose (16) from tee (19).

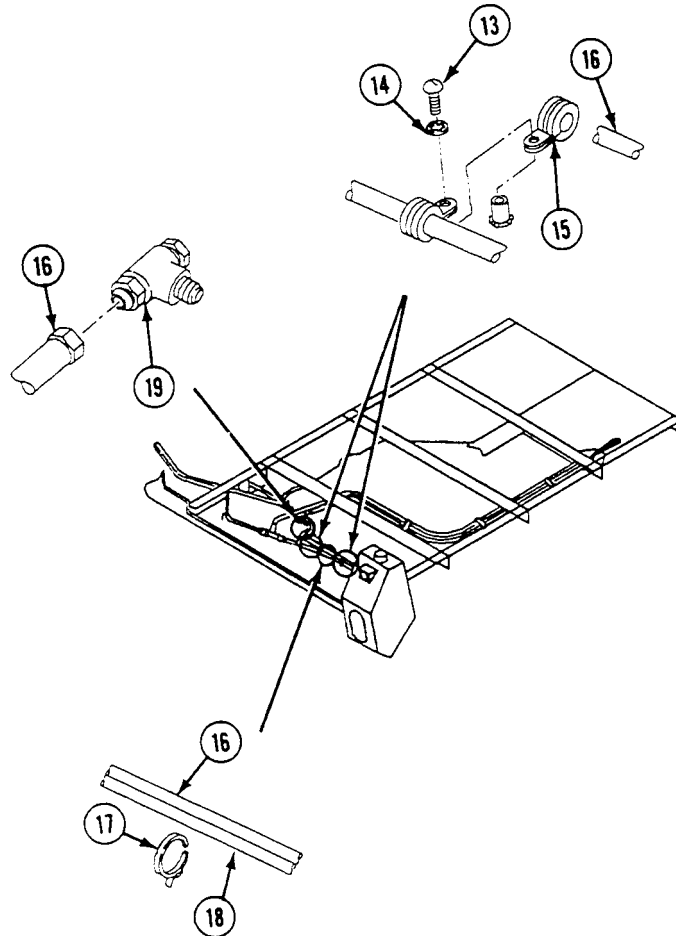

**REPLACE FUEL RETURN HOSES, TUBES, AND FITTINGS (M113A3,
M1059A3, AND M58 ONLY) — Continued**

0195 00

22. Remove two screws (1), washers (2), and clamps (3) securing valve (4) to mounting block (5).
23. Remove hose (6) from adapter (7).
24. Remove adapter (7) from valve (4).
25. Remove hose (8) from adapter (9).
26. Remove adapter (9) from valve (4).
27. Remove five screws (10), washers (11), lockwashers (12), and guard (13) from bulkhead. Discard lockwashers.
28. Remove hose (8) from elbow (14).
29. Remove elbow (14) from adapter (15).
30. Remove adapter (15) from fuel tank (16).

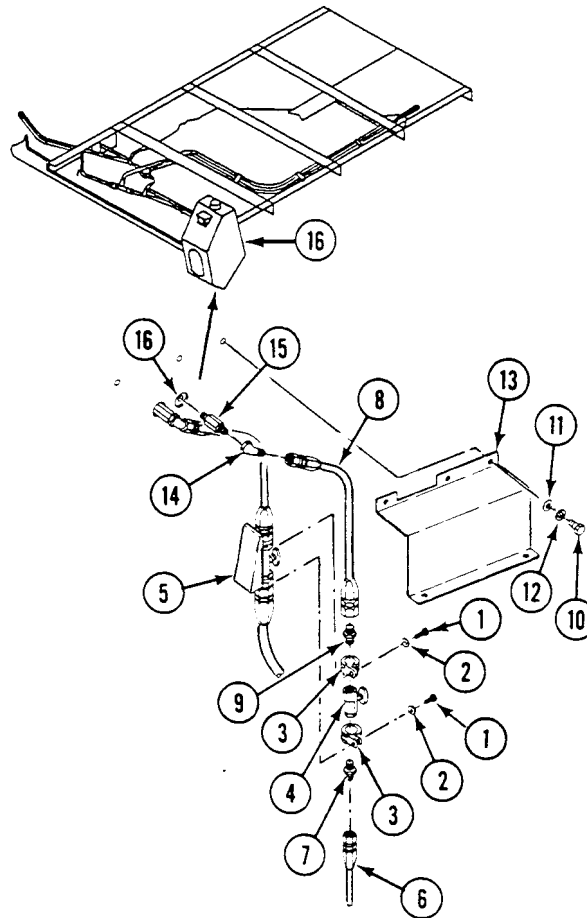

INSTALLATION

NOTE

Do Steps 1 - 13 for installing right side fuel tank return hoses and fittings. Do Steps 14 - 26 for installing left side fuel tank return hoses and fittings.

1. Apply sealing compound to external threads of adapter (15). Install adapter on fuel tank (16).
2. Apply sealing compound to external threads of elbow (14). Install elbow on adapter (15).
3. Apply caulking compound to space around adapter (15) on rear hull plate.
4. Install hose (8) on elbow (14).
5. Install guard (13) on bulkhead and secure with five washers (11), new lockwashers (12), and screws (10).
6. Apply sealing compound to external threads of adapter (9). Install adapter in valve (4).
7. Install hose (8) on adapter (9).
8. Apply sealing compound to external threads of adapter (7). Install adapter in valve (4).
9. Install hose (6) on adapter (7).
10. Secure valve (4) to mounting block (5) with two clamps (3), washers (2), and screws (1).

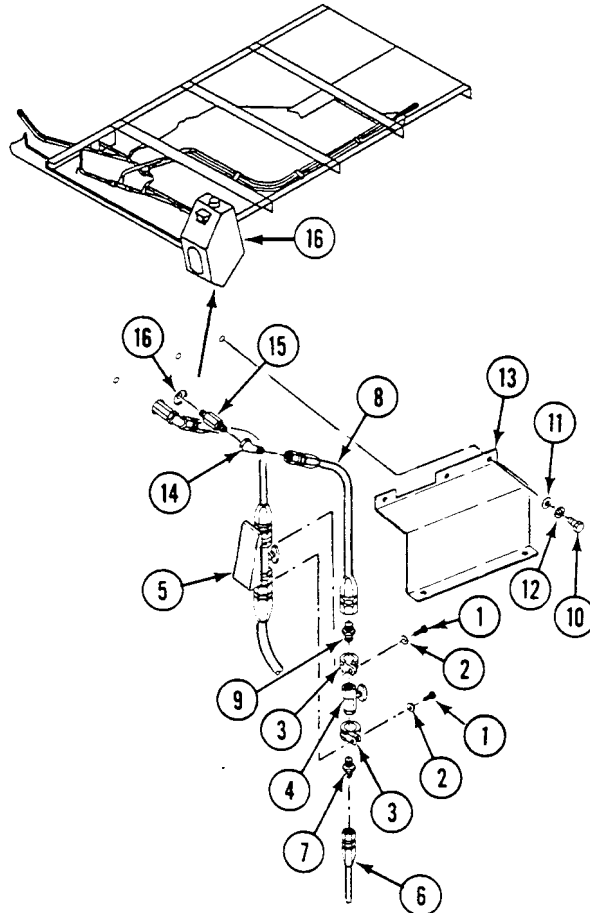

**REPLACE FUEL RETURN HOSES, TUBES, AND FITTINGS (M113A3,
M1059A3, AND M58 ONLY) — Continued**

0195 00

11. Install hose (1) on tee (2).
12. Install three clamps (3) on hose (1). Secure clamps to carrier with two screws (4) and new lockwashers (5).
13. Install two new tie down straps (6) on two hoses (1) and (7).

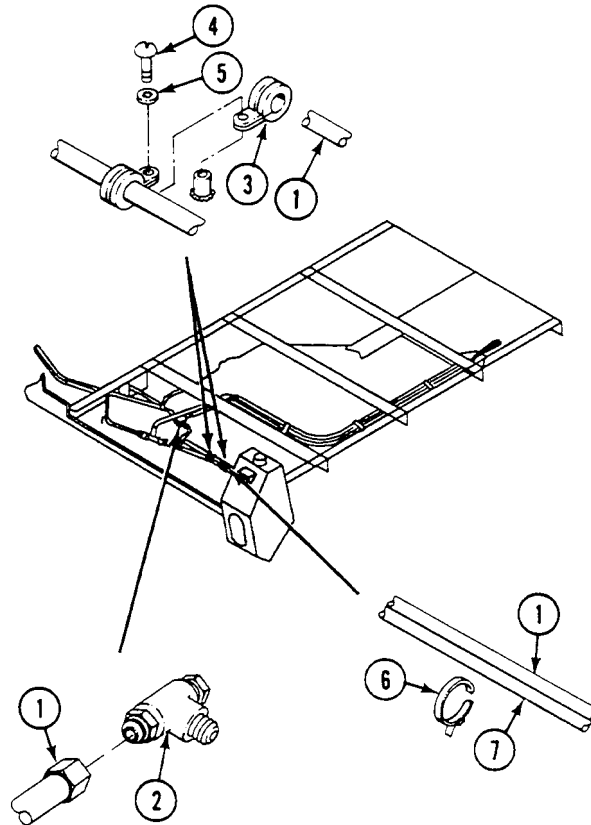

**REPLACE FUEL RETURN HOSES, TUBES, AND FITTINGS (M113A3,
M1059A3, AND M58 ONLY) — Continued**

0195 00

14. Apply sealing compound to external threads of adapter (8). Install adapter on fuel tank (9).
15. Apply sealing compound to external threads of elbow (10). Install elbow on adapter (8).
16. Apply caulking compound to space around adapter (8) on rear hull plate.
17. Install hose (11) on elbow (10).
18. Apply sealing compound to external threads of adapter (12). Install adapter on valve (13).
19. Install hose (11) on adapter (12).
20. Apply sealing compound to external threads of adapter (14). Install adapter on valve (13).
21. Install hose (15) on adapter (14).
22. Secure valve (13) to mounting block (16) with clamp (17), new lockwasher (18), and screw (19).

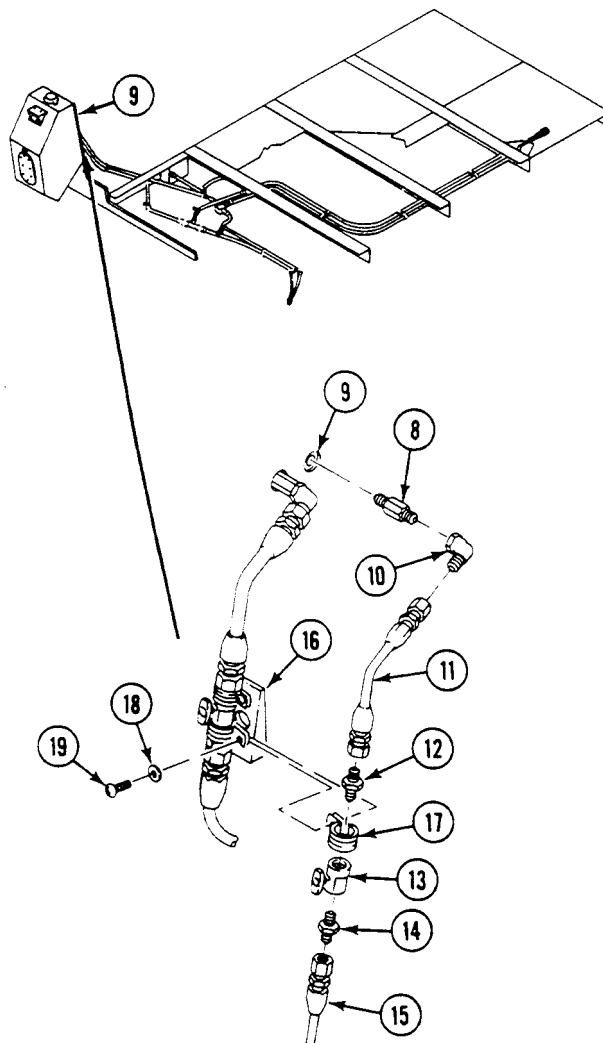

**REPLACE FUEL RETURN HOSES, TUBES, AND FITTINGS (M113A3,
M1059A3, AND M58 ONLY) — Continued**

0195 00

23. Install hose (1) on tee (2).
24. Install clamp (3) on hose (1). Secure hose to carrier with screw (4) and new lockwasher (5).
25. Install new tiedown strap (6) on two hoses (1) and (7).

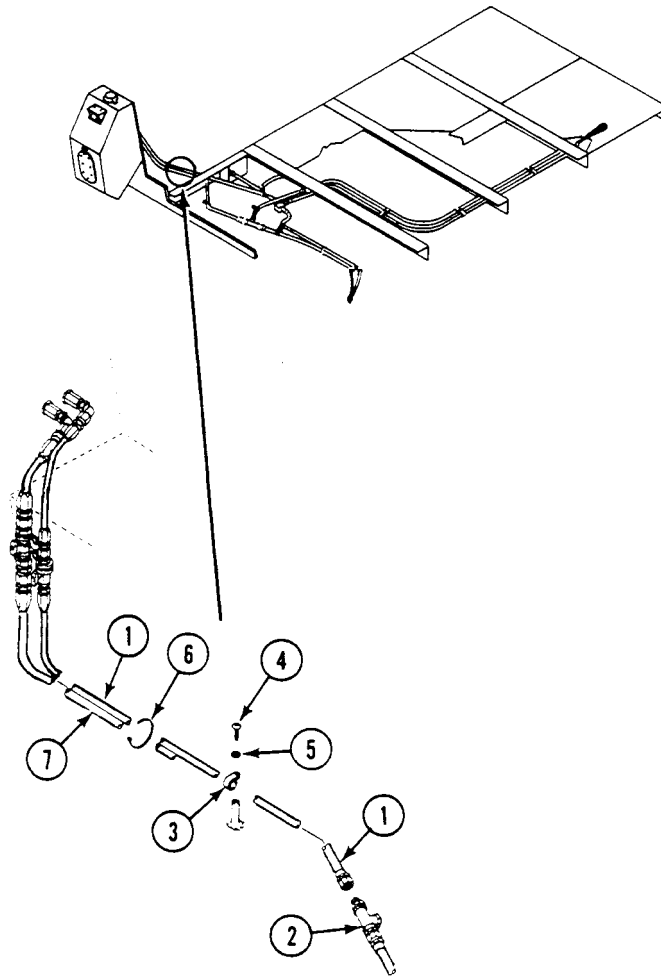

REPLACE FUEL RETURN HOSES, TUBES, AND FITTINGS (M113A3, M1059A3, AND M58 ONLY) — Continued

0195 00

26. Install guard (8) on bulkhead. Secure side of guard with washer (9) and screw (10). Secure top of guard with screw (11) and new locknut (12).
27. Install hose (13) on tee (2).
28. Install five clamps (14) on hose (13). Secure hose to carrier with five screws (15) and new lockwashers (16).

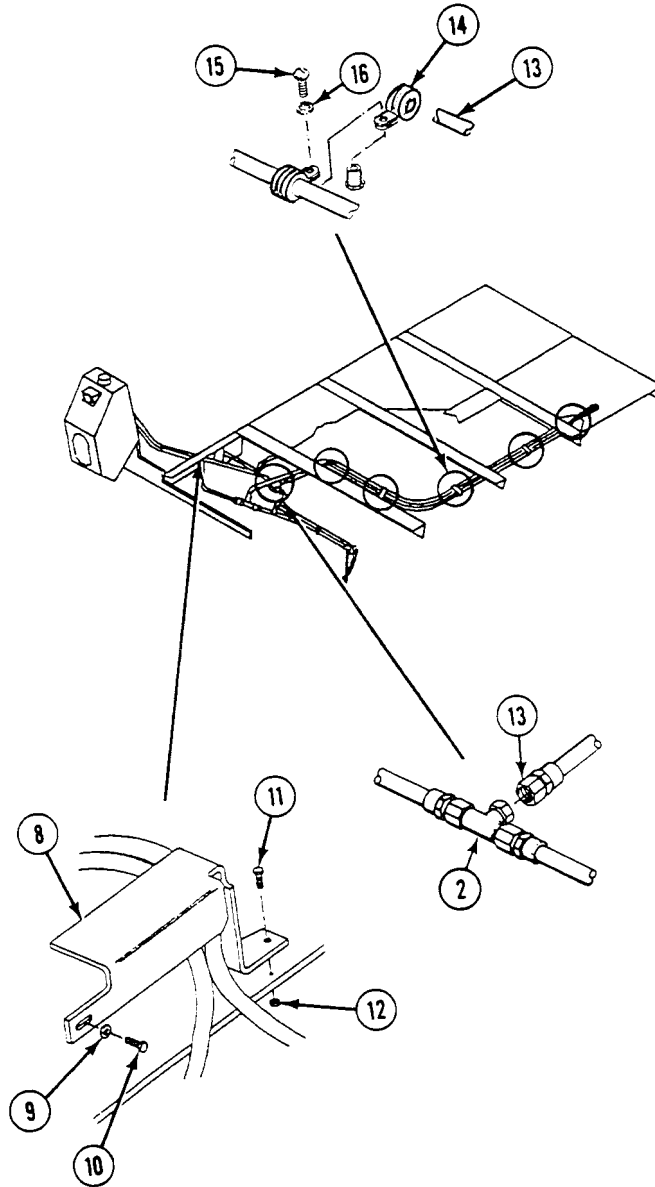

29. Install grommet (1) on hose (2). Route hose through hole in bulkhead and install grommet in bulkhead.
30. Install hose (2) on elbow (3). Hold elbow when tightening hose.

REPLACE FUEL RETURN HOSES, TUBES, AND FITTINGS (M113A3, M1059A3, AND M58 ONLY) — Continued

0195 00

31. Install quick disconnect coupler body (4) on quick disconnect coupler nose (5).

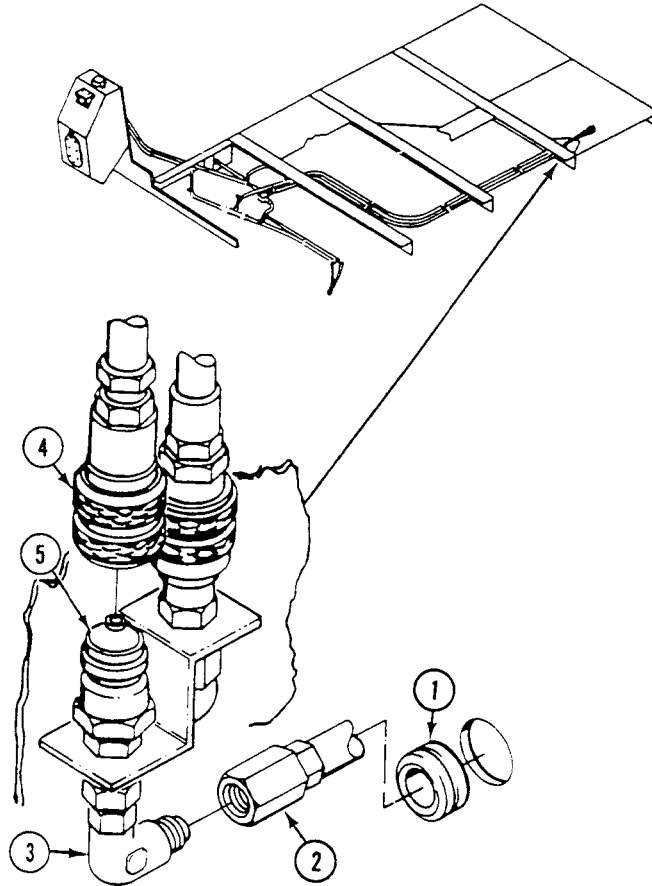
FOLLOW-THROUGH STEPS

1. Fill fuel tanks (WP 0177 00).
2. Connect battery ground strap (WP 0337 00).
3. Start engine (see your -10). Check for leaks.
4. Stop engine (see your -10).
5. Install floor plates (WP 0539 00), (WP 0542 00), or (WP 0545 00).
6. Install power plant lower rear access panel (see your -10).
7. Install smoke generator fog oil tank module (M1059A3 only) (WP 0753 00).
8. Install smoke generator system (M58 only) TM 3-1040-285-20
9. Start engine (see your -10).
10. Raise and lock ramp (see your -10).
11. Stop engine (see your -10).

END OF TASK

REPLACE FUEL RETURN HOSES, TUBES, AND FITTINGS (M577A3 AND M1068A3 ONLY)

0196 00

THIS WORK PACKAGE COVERS:

Removal (page 0196 00-1).
 Installation (page 0196 00-4).

INITIAL SETUP:

Maintenance Level

Unit

Tools and Special Tools

General Mechanic's Tool Kit (WP 0926 00, Item 65)

Materials/Parts

Sealing compound (WP 0928 00, Item 56)

Wiping rag (WP 0928 00, Item 65)

Grommet

Lockwasher (13)

Personnel Required

Unit Mechanic

References

See your -10

Equipment Condition

Engine stopped (see your -10)

Carrier blocked (see your -10)

Ramp lowered (see your -10)

Battery ground lead disconnected (WP 0338 00)

Map board removed (see your -10)

Work tables removed (WP 0578 00)

or (WP 0581 00 and WP 0582 00)

Power plant lower rear access panel removed
 (WP 0439 00)

Rear floor plates removed (WP 0539 00) or
 (WP 0544 00)

REMOVAL

NOTE

Use wiping rag to wipe up any spilled fuel.

1. Disconnect auxiliary generator return hose (1) from tee (2).
2. Remove return tube (3) from elbow (4).
3. Remove cap (5) and elbow (4) from tee (2).
4. Remove three screws (6), lockwashers (7), and clamps (8) from weldnuts on right hull plate. Discard lockwashers.
5. Disconnect return tube (3) from tee (9) on fuel filler tube (10).

REPLACE FUEL RETURN HOSES, TUBES, AND FITTINGS (M577A3 AND M1068A3 ONLY) — Continued

0196 00

6. Remove clamps (8) from return tube (3).

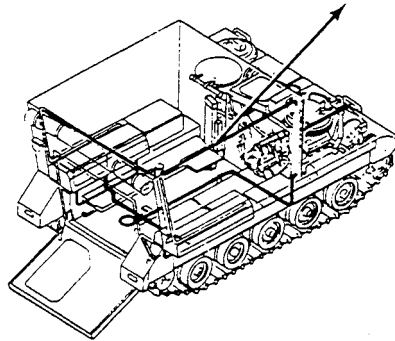
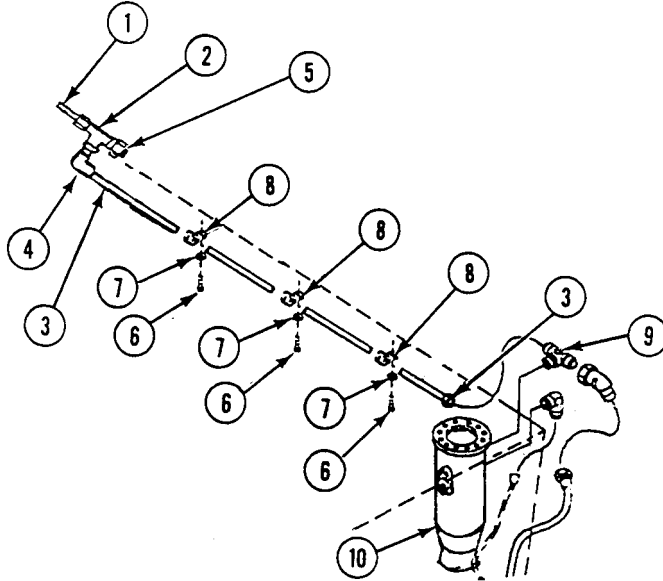

7. Remove fuel return hose (1) from elbow (2).
8. Remove elbow (2) from tee (3).
9. Remove tee (3) from fuel filler tube (4).

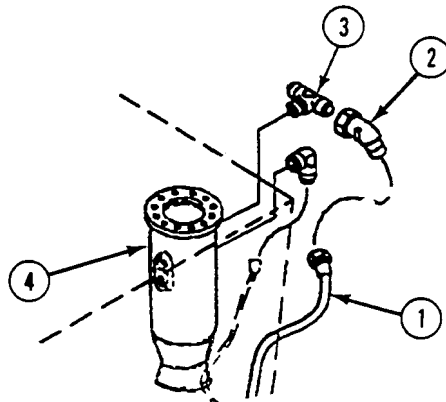

REPLACE FUEL RETURN HOSES, TUBES, AND FITTINGS (M577A3 AND M1068A3 ONLY) — Continued

0196 00

10. Remove two screws (5), lockwashers (6), and clamps (7) from weldnuts on rear hull plate. Discard lockwashers.
11. Remove clamps (7) from fuel return hose (8).
12. Remove eight screws (9), lockwashers (10) and clamps (11) from weldnuts on right box beam and bottom hull plate. Discard lockwashers.
13. Remove eight clamps (11) from fuel return hose (8).

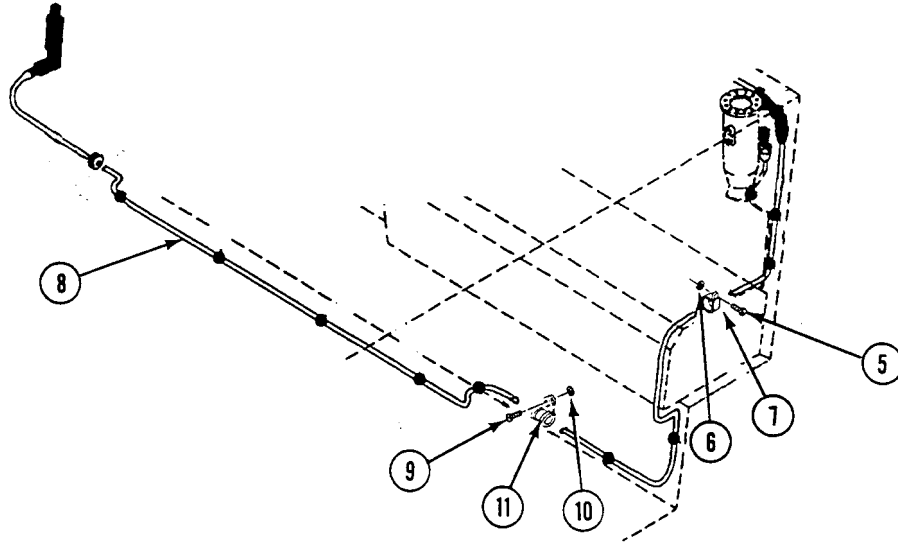

14. Separate quick-disconnect coupler (12) from coupler nose (13) inside power plant rear bulkhead.
15. Remove fuel return hose (14) from elbow (15).
16. Remove fuel return hose (14) and grommet (16) from bulkhead. Discard grommet.
17. Remove elbow (15) from reducer (17).
18. Remove nut (18) and reducer (17) from coupler nose (13).

REPLACE FUEL RETURN HOSES, TUBES, AND FITTINGS (M577A3 AND M1068A3 ONLY) — Continued

0196 00

19. Remove nut (19) and coupler nose (13) from bracket.

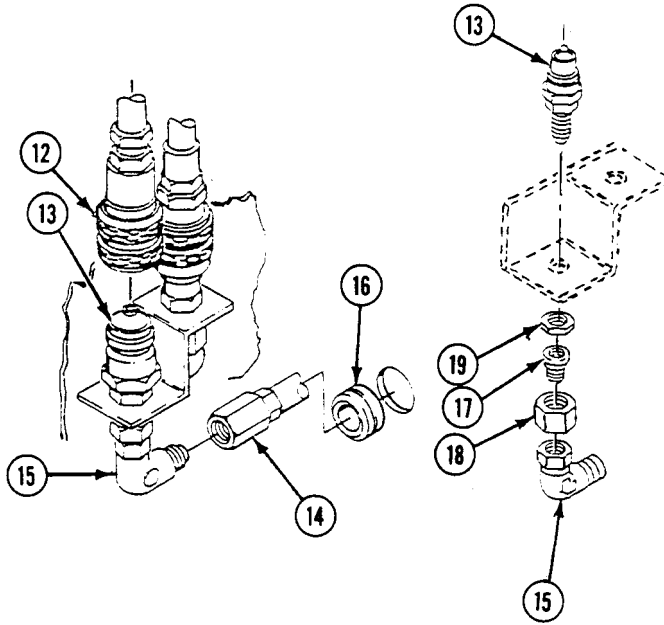

INSTALLATION

1. Apply thin even coat of sealing compound to cleaned external threads of fittings before installation.
2. Install coupler nose (1) in bracket and secure with nut (2).
3. Install reducer (3) and nut (4) on coupler nose (1).
4. Install elbow (5) on reducer (3).

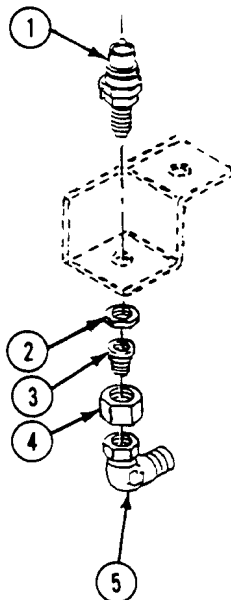

REPLACE FUEL RETURN HOSES, TUBES, AND FITTINGS (M577A3 AND M1068A3 ONLY) — Continued

0196 00

5. Install new grommet (6) on fuel return hose (7) and secure through bulkhead.
6. Connect fuel return hose (7) to elbow (5).
7. Connect quick-disconnect (8) to coupler nose (1).

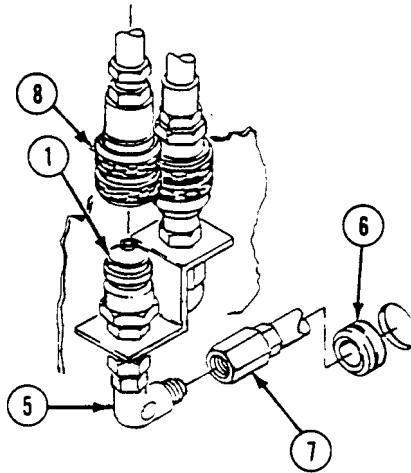

8. Install eight clamps (9) on fuel return hose (10) and secure to bottom hull plate and right box beam with new lockwashers (11), and screws (12).
9. Install two clamps (13) on fuel return hose (10) and secure to rear hull plate with new lockwashers (14), and screws (15).

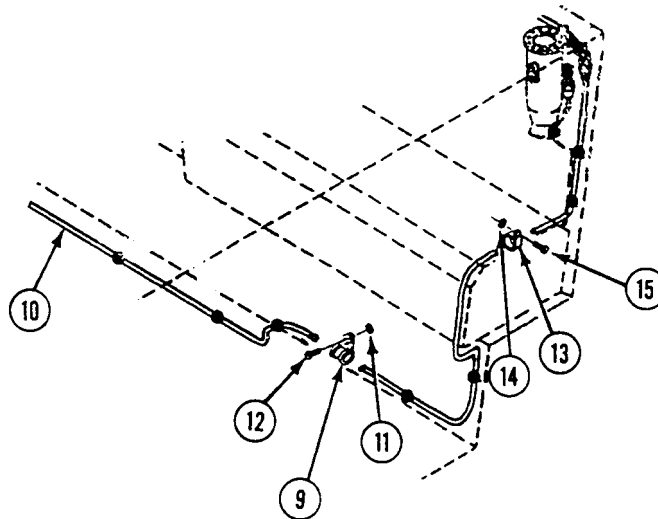

REPLACE FUEL RETURN HOSES, TUBES, AND FITTINGS (M577A3 AND M1068A3 ONLY) — Continued

0196 00

10. Install tee (16) in fuel filler tube (17).
11. Install elbow (18) on tee (16).
12. Connect fuel return hose (10) to elbow (18).

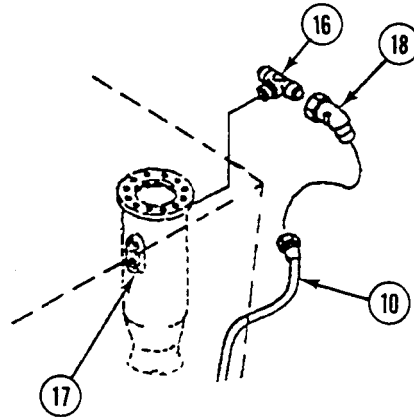

13. Connect auxiliary generator fuel return tube (1) to tee (2).
14. Install three clamps (3) on fuel return tube (1). Secure with new lockwashers (4) and screws (5) to weldnuts on right hull plate.
15. Install auxiliary generator fuel return hose (6) on tee (7).
16. Install cap (8) and elbow (9) on tee (7).
17. Connect auxiliary generator fuel return tube (1) to tee (7).

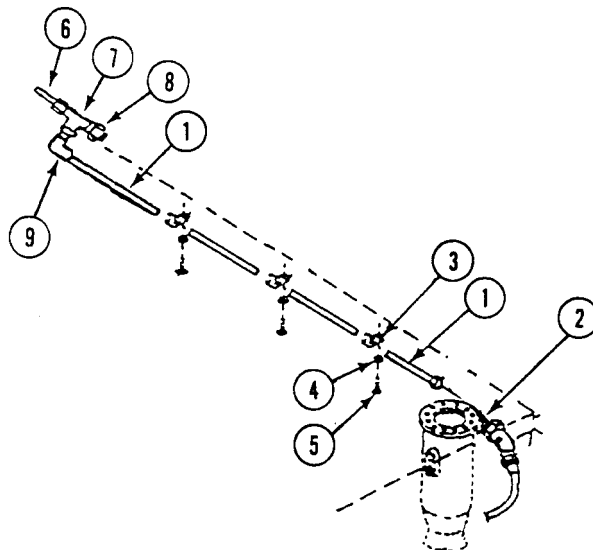

REPLACE FUEL RETURN HOSES, TUBES, AND FITTINGS (M577A3 AND M1068A3 ONLY) — Continued

0196 00

FOLLOW-THROUGH STEPS

1. Fill fuel tanks (see your -10).
2. Connect battery ground leads (WP 0338 00).
3. Start engine (see your -10).
4. Check all fittings and hoses for leaks.
5. Stop engine (see your -10).
6. Install power plant rear access panel (WP 0439 00).
7. Install rear floor plates (WP 0539 00) or (WP 0544 00).
8. Install work tables (WP 0578 00) or (WP 0581 00 and WP 0582 00).
9. Install map table (see your -10).
10. Start engine (see your -10).
11. Raise and lock ramp (see your -10).
12. Stop engine (see your -10).

END OF TASK

REPLACE FUEL RETURN HOSES, TUBES, AND FITTINGS (M1064A3 ONLY)

0197 00

THIS WORK PACKAGE COVERS:

Remove (page 0197 00-1).
 Installation (page 0197 00-9).

INITIAL SETUP:

Maintenance Level

Unit

References

TM 9-2350-277-10

Tools and Special Tools

General Mechanic's Tool Kit (WP 0926 00, Item 65)

Equipment Condition

Engine stopped (see your -10)
 Carrier blocked (see your -10)
 Ramp lowered (see your -10)
 Power plant lower rear access panel removed (see your -10)
 Battery ground strap disconnected (WP 0337 00)
 Fuel tanks drained (see your -10)
 Heater duct removed (WP 0706 00)
 Rear floor plates removed (WP 0543 00)

Materials/Parts

Calking compound (WP 0928 00, Item 14)
 Sealing compound (WP 0928 00, Item 56)
 Grommet
 Lockwasher (5)
 Strap (2)

Personnel Required

Unit Mechanic

REMOVAL

1. Separate quick-disconnect coupler (1) from coupler nose (5) inside power plant rear bulkhead.
2. Remove fuel return hose (3) from elbow (4).
3. Remove fuel return hose (3) and grommet (2) from bulkhead. Discard grommet.

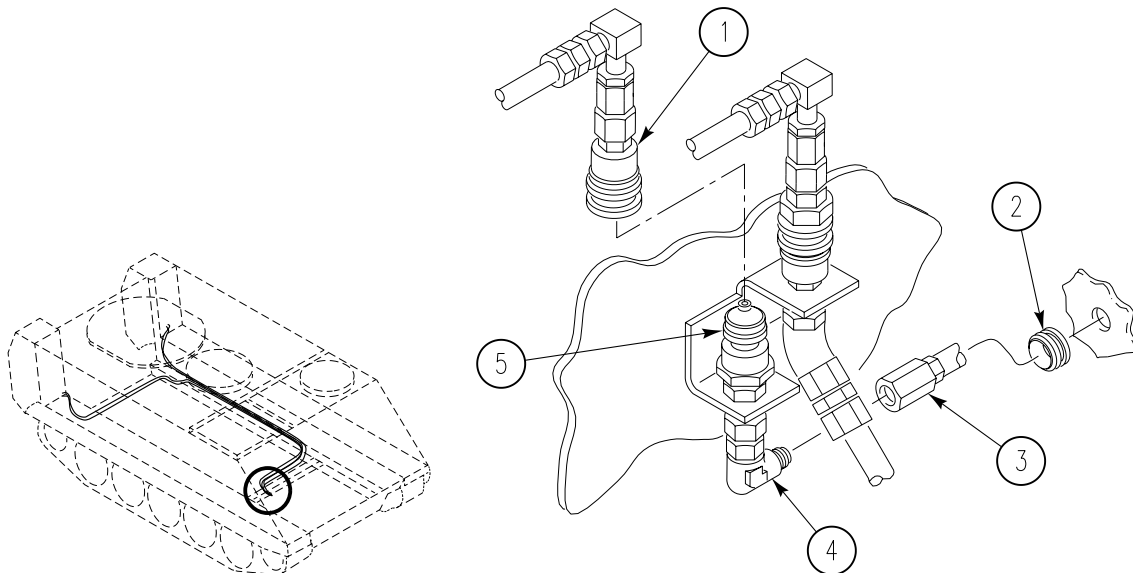

REPLACE FUEL RETURN HOSES, TUBES, AND FITTINGS (M1064A3 ONLY) —**0197 00**

Continued

4. Remove elbow (4) from reducer (6).
5. Remove nut (7) and reducer (6) from coupler nose (2).
6. Remove nut (8) and coupler nose (2) from bracket.

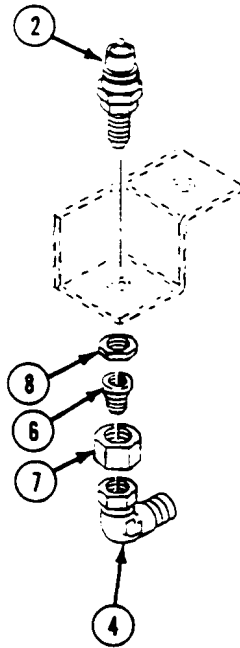

7. Remove four screws (12), lockwashers (11), and eight clamps (10) from weldnuts. Discard lockwashers.
8. Remove clamps (10) from fuel return hose (13).
9. Remove floor plate screw (8) and washer (9) from guard (6).
10. Remove screw (14), washer (15), nut (7), and guard (6).
11. Disconnect fuel return hose (13) from adapter (5).
12. Remove adapter (5) from elbow (4).
13. Remove elbow (4) and adapter (16) from fuel return tube (17).
14. Remove adapter (16) from elbow (4).

REPLACE FUEL RETURN HOSES, TUBES, AND FITTINGS (M1064A3 ONLY) —
Continued

0197 00

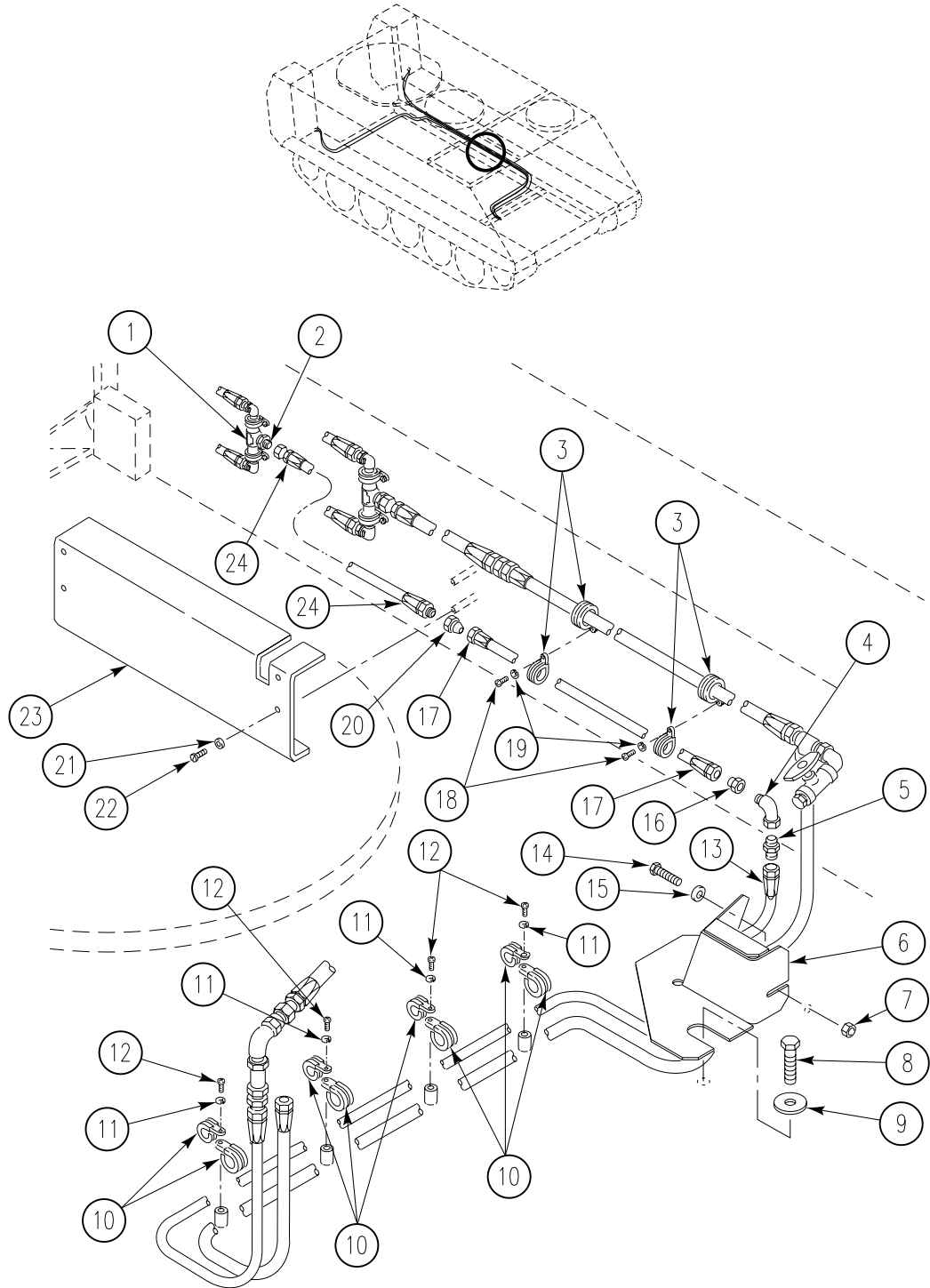

**REPLACE FUEL RETURN HOSES, TUBES, AND FITTINGS (M1064A3 ONLY) —
Continued**

0197 00

15. Remove two screws (18), lockwashers (19) and four clamps (3) from weldnuts. Discard lockwashers.
16. Remove clamps from fuel return tube (17).
17. Remove four screws (22), lockwashers (21), and guard (23) from sponson. Discard lockwashers.
18. Disconnect fuel return tube (17) from adapter (20).
19. Remove adapter (20) from fuel return hose (24).
20. Remove fuel return hose (24) from adapter (2).
21. Remove adapter (2) from tee (1).

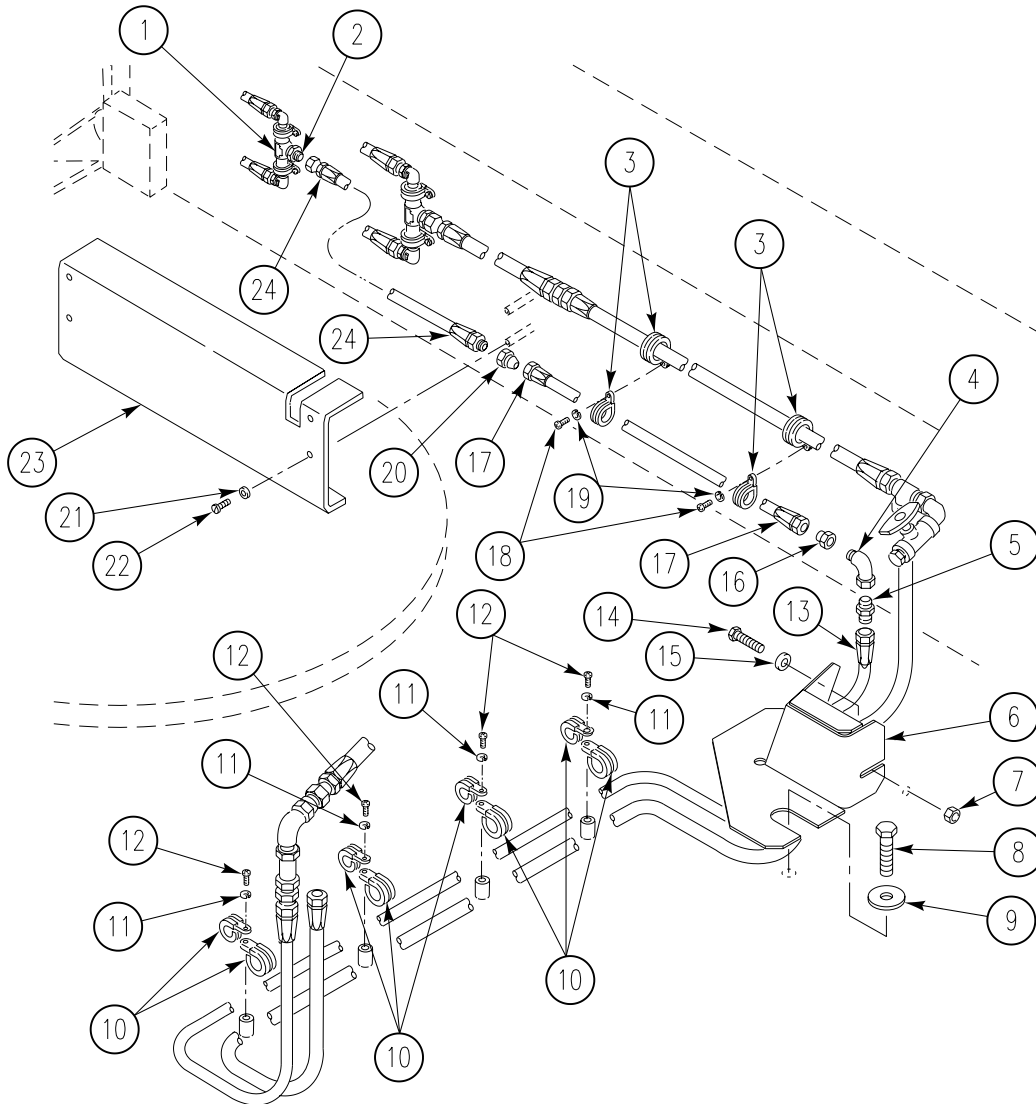

REPLACE FUEL RETURN HOSES, TUBES, AND FITTINGS (M1064A3 ONLY) —
Continued

0197 00

22. Disconnect two fuel return hoses (1) and (2) from two elbows (3).
23. Remove two screws (4), lockwashers (5) and clamps (6) from weldnuts. Discard lockwashers.
24. Remove two clamps (6) and elbows (3) from tee (7).

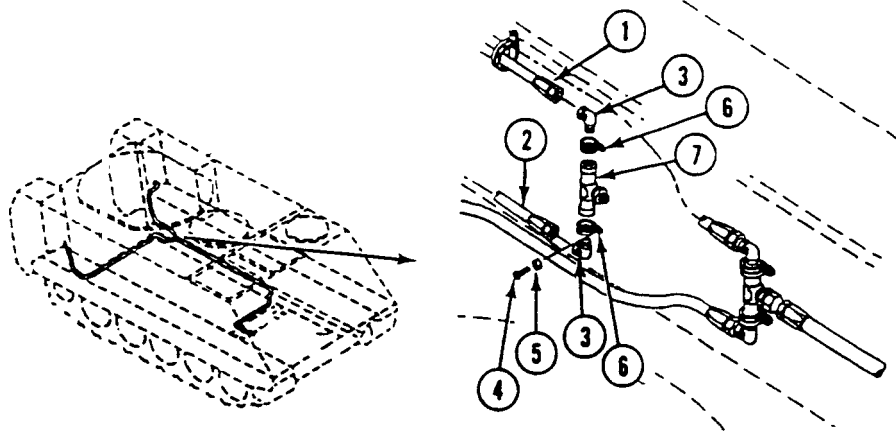

Continued

NOTE

Do Steps 23 - 30 for removing left side fuel tank return hoses and fittings. Do Steps 33 - 42 for removing right side fuel tank return hoses and fittings.

25. Remove two screws (8), washers (9), and clamps (10) securing valve (11) to mounting block (12).
26. Remove hose (1) from adapter (13).
27. Remove adapter (13) from valve (11).
28. Remove hose (14) from adapter (15).
29. Remove adapter (15) from valve (11).
30. Remove hose (14) from elbow (16).
31. Remove elbow (16) from adapter (17).
32. Remove adapter (17) from fuel tank (18).

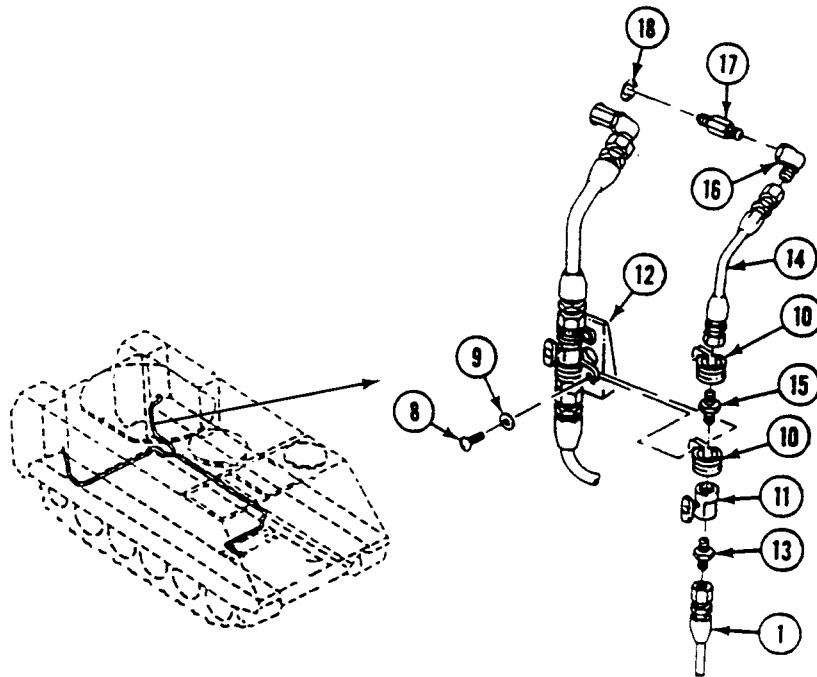

REPLACE FUEL RETURN HOSES, TUBES, AND FITTINGS (M1064A3 ONLY) —
Continued

0197 00

33. Remove three screws (19), lockwashers (20), and clamps (21) from weldnuts. Discard lockwashers.
34. Remove clamps (21) and straps (22) from fuel return hose (2), wiring harness, and bilge pump tube.

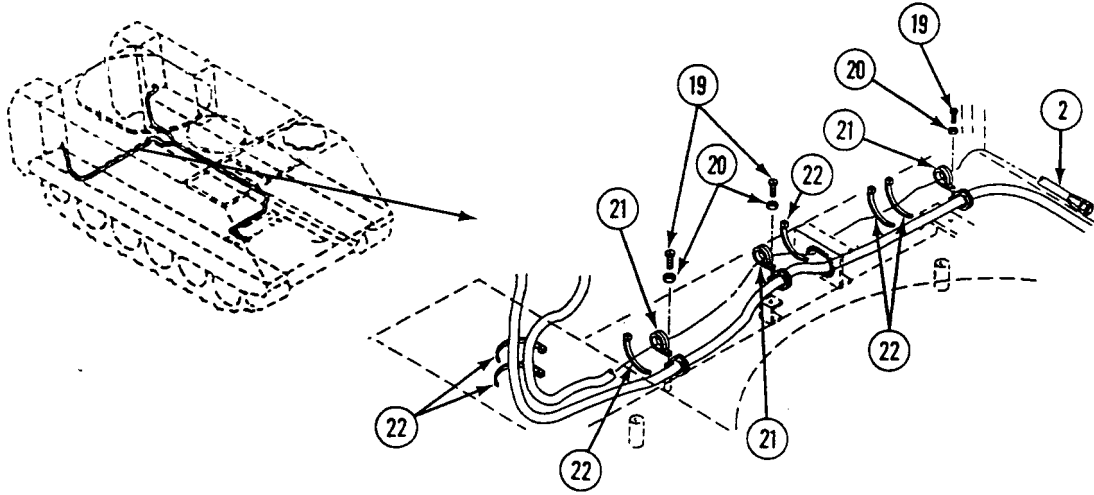

**REPLACE FUEL RETURN HOSES, TUBES, AND FITTINGS (M1064A3 ONLY) —
Continued**

0197 00

35. Remove two straps (10) securing valve (6) to fuel supply hoses and bilge tube (11). Discard straps.

NOTE

Replace grommet only if necessary.

36. Remove hose (8) and grommet (9) from adapter (7).
 37. Remove adapter (7) from valve (6).
 38. Remove fuel return hose (4) from adapter (5).
 39. Remove adapter (5) from valve (6).
 40. Remove fuel return hose (4) from elbow (3).
 41. Remove elbow (3) from adapter (2).
 42. Remove adapter (2) from fuel tank (1).

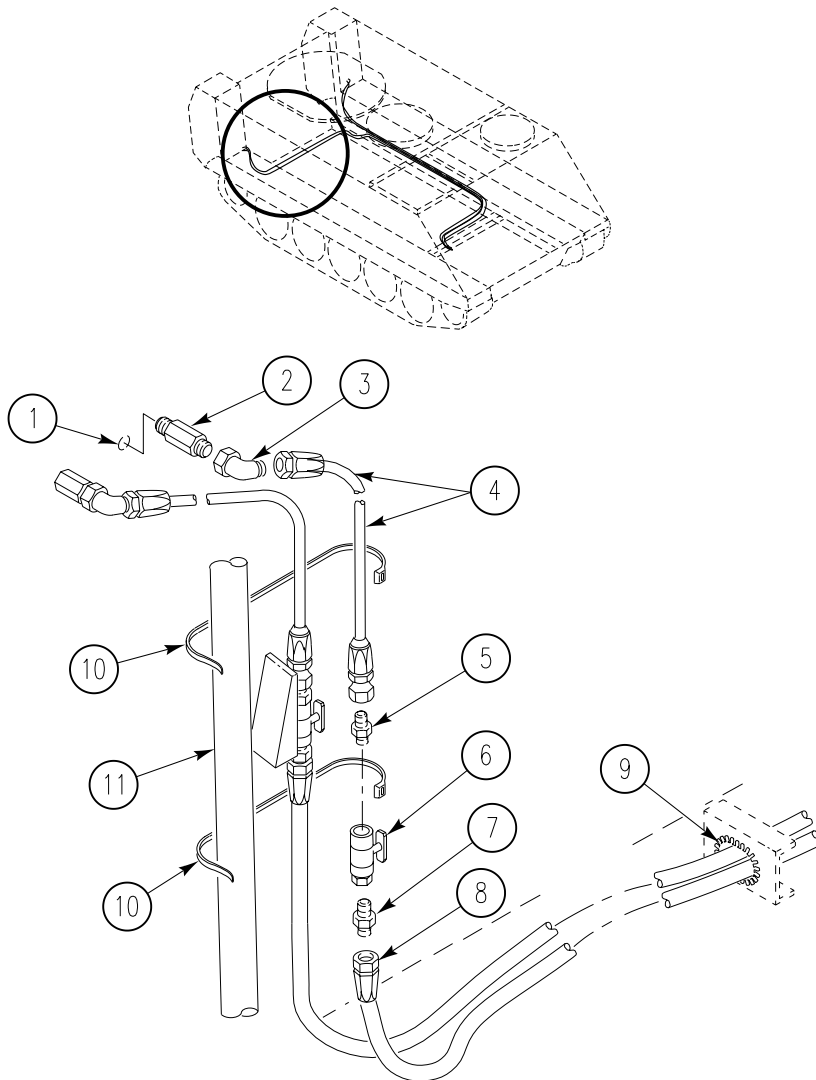

REPLACE FUEL RETURN HOSES, TUBES, AND FITTINGS (M1064A3 ONLY) —
Continued

0197 00

INSTALLATION**NOTE**

Do Steps 1 - 9 for installing right side fuel tank return hoses and fittings. Do Steps 20 - 29 for installing left side fuel return hoses and fittings.

1. Apply sealing compound to external threads of adapter (2) and install on fuel tank (1).
2. Apply sealing compound to external threads of elbow (3) and install on adapter (2).
3. Apply calking compound to space around adapter (2) on rear hull plate.
4. Install fuel return hose (4) on elbow (3).
5. Apply sealing compound to external threads of adapter (5) and install in valve (6).

NOTE

Apply adhesive to new grommet before installing.

6. Install fuel return hose (4) through grommet (9) and on adapter (5).
7. Apply sealing compound to external threads of adapter (7) and install in valve (6).
8. Connect fuel return hose (8) to adapter (7).
9. Secure valve (6) to fuel supply hoses and bilge tube (11) with two new straps. (10).

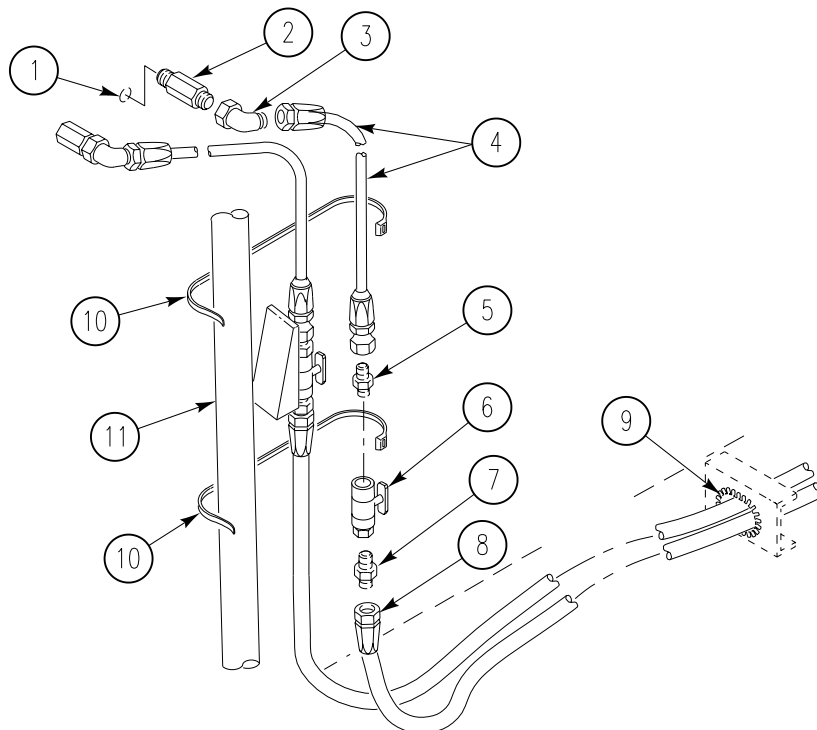

**REPLACE FUEL RETURN HOSES, TUBES, AND FITTINGS (M1064A3 ONLY) —
Continued**

0197 00

10. Install three clamps (14) and straps (15) on fuel return hose (6), wiring harness, and bilge pump tube.
11. Install three screws (16), new lockwashers (17), and clamps (14) on weldnuts.

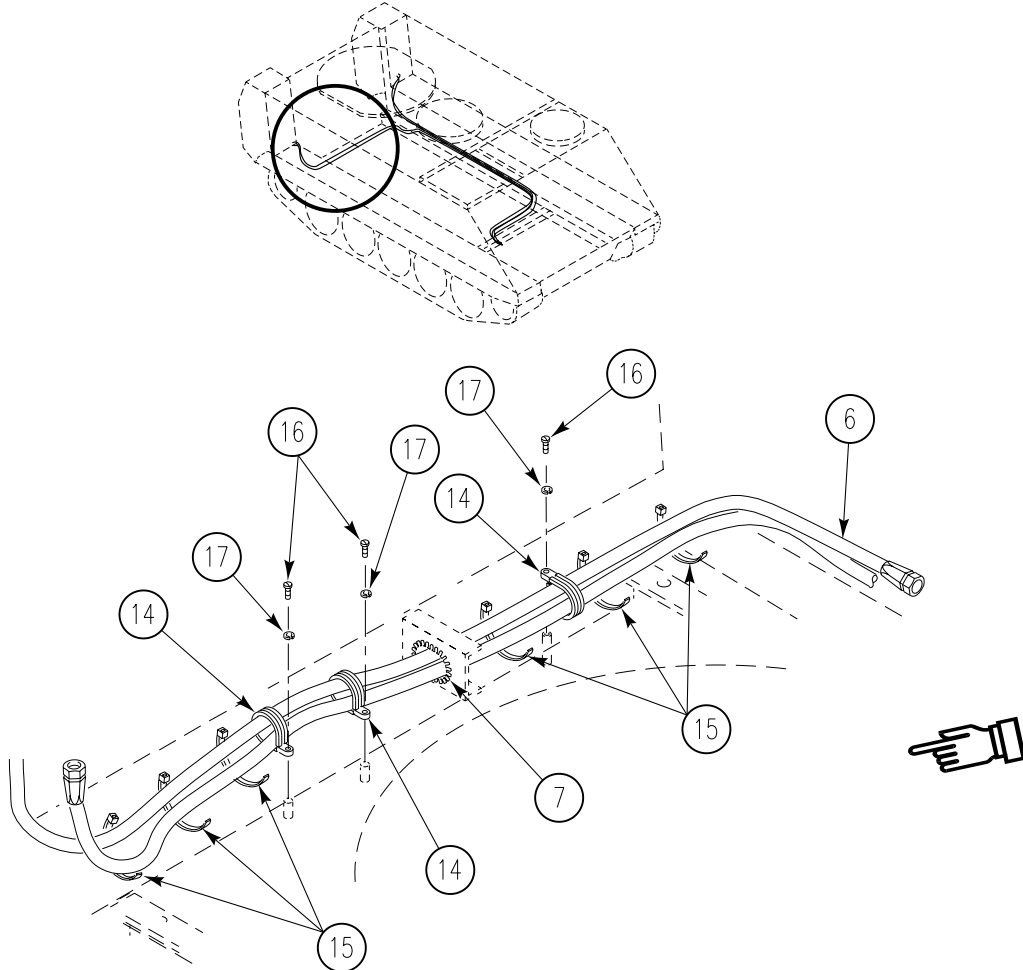

**REPLACE FUEL RETURN HOSES, TUBES, AND FITTINGS (M1064A3 ONLY) —
Continued**

0197 00

12. Apply sealing compound to external threads of adapter (1) and install on fuel tank (2).
13. Apply sealing compound on internal threads of elbow (3) and install on adapter (1).
14. Apply calking compound to space around adapter (1) on rear of hull plate.
15. Install fuel return hose (4) on elbow (3).
16. Apply sealing compound to external threads of adapter (5) and install on valve (6).
17. Install fuel return hose (4) on adapter (5).
18. Apply sealing compound to external threads of adapter (7) and install on valve (6).

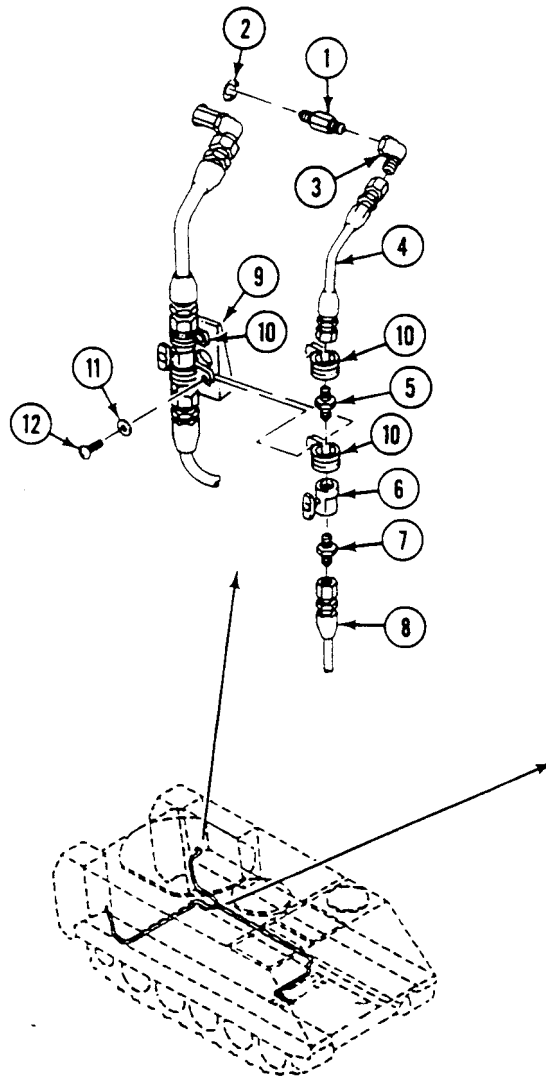

REPLACE FUEL RETURN HOSES, TUBES, AND FITTINGS (M1064A3 ONLY) —**0197 00****Continued**

19. Install fuel return hose (8) on adapter (7).
20. Align valve (6) on mounting block (9) and secure with two clamps (10), washers (11), and screws (12).
21. Apply sealing compound to external threads of two elbows (13) and tee (14). Install two elbows (13) and clamps (15) on tee (14).
22. Install two new lockwashers (16), screws (17), and clamps (10) on weldnuts.
23. Connect left fuel return hose (8) and right fuel return hose (18) to elbows (13).
24. Install adapter (19) on tee (14).

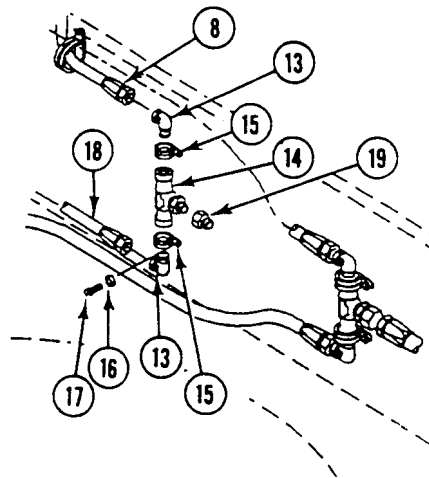

REPLACE FUEL RETURN HOSES, TUBES, AND FITTINGS (M1064A3 ONLY) —
Continued

0197 00

25. Connect fuel return hose (24) to adapter (2) and tee (1).
26. Apply sealing compound to external threads of adapter (20) and install on fuel return hose (24).
27. Connect fuel return tube (17) to adapter (20).
28. Install guard (23), four new lockwashers (21), and screws (22) on sponson.
29. Install two clamps (3) on fuel return tube (17).
30. Install four clamps (3), two new lockwashers (19), and screws (18) on weldnuts.

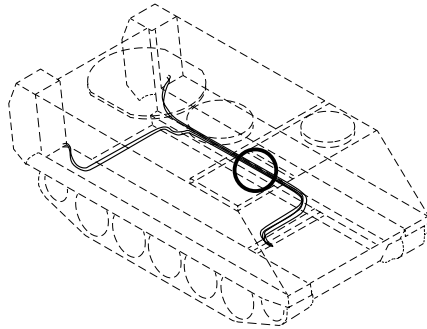

REPLACE FUEL RETURN HOSES, TUBES, AND FITTINGS (M1064A3 ONLY) —
Continued

0197 00

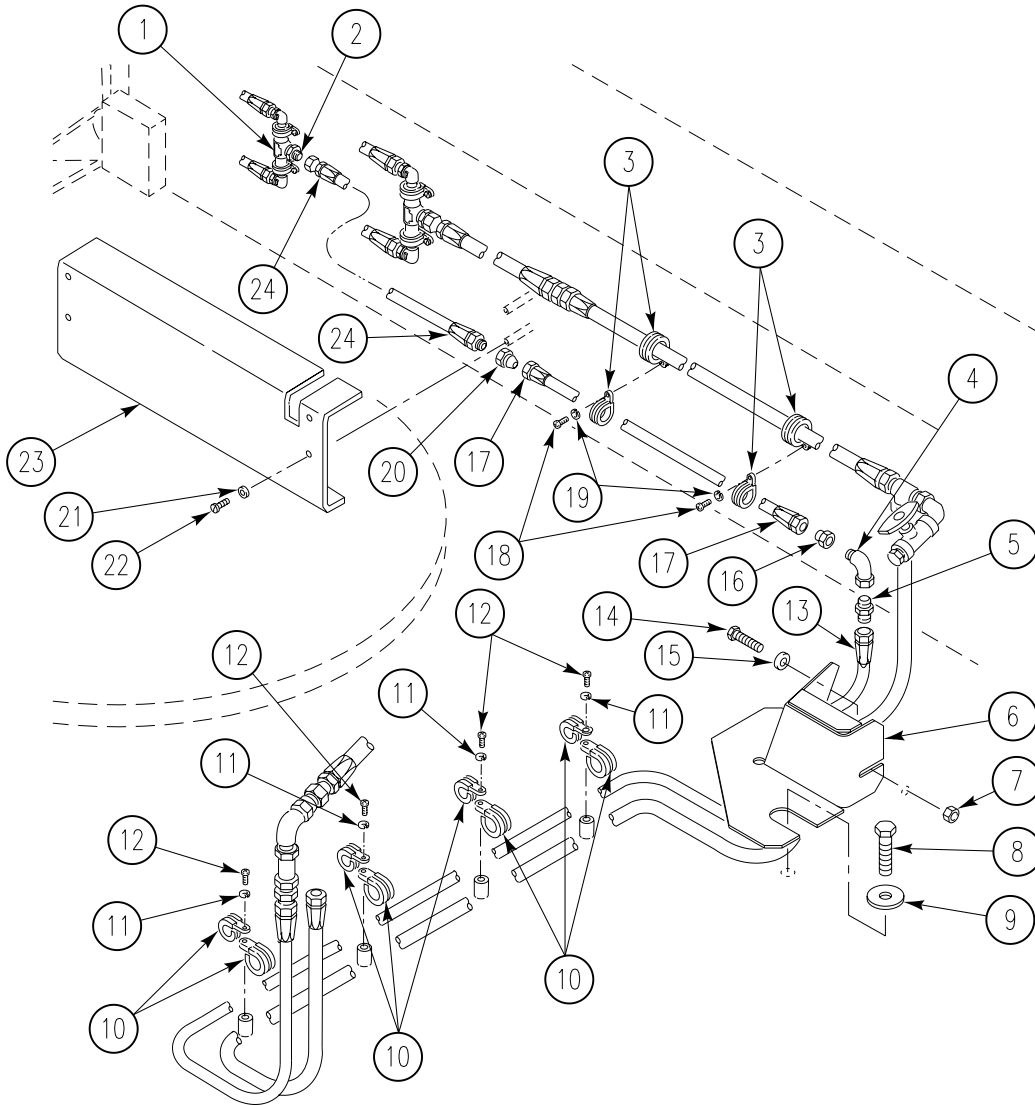

**REPLACE FUEL RETURN HOSES, TUBES, AND FITTINGS (M1064A3 ONLY) —
Continued**

0197 00

31. Apply sealing compound to external threads of elbow (4). Install adapter (16) and adapter (5) on elbow (4).
32. Connect fuel return tube (17) to adapter (16).
33. Connect fuel return hose (13) to adapter (5).
34. Install four clamps (10) on fuel return hose (13).
35. Install four screws (12), new lockwashers (11), and eight clamps (10) on weldnuts.
36. Install guard (6), two washers (15), screws (14), and nut(7) .
37. Install floor plate screw (8) and washer (9) to secure guard (6).

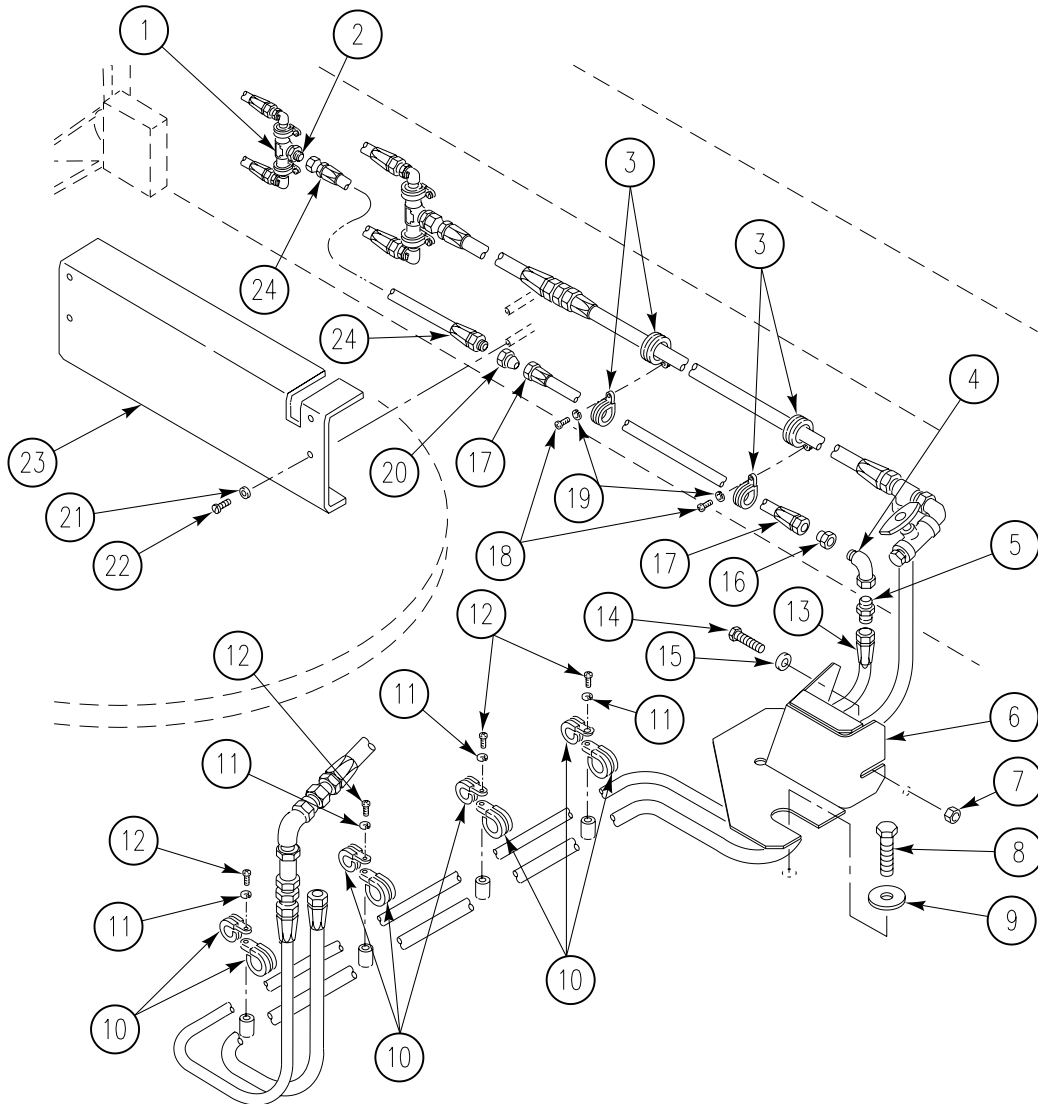

REPLACE FUEL RETURN HOSES, TUBES, AND FITTINGS (M1064A3 ONLY) —
Continued

0197 00

38. Install coupler nose (1) in bracket and secure with nut (2).
39. Install reducer (3) and nut (4) on coupler nose (1).
40. Install elbow (5) on coupler nose (1).

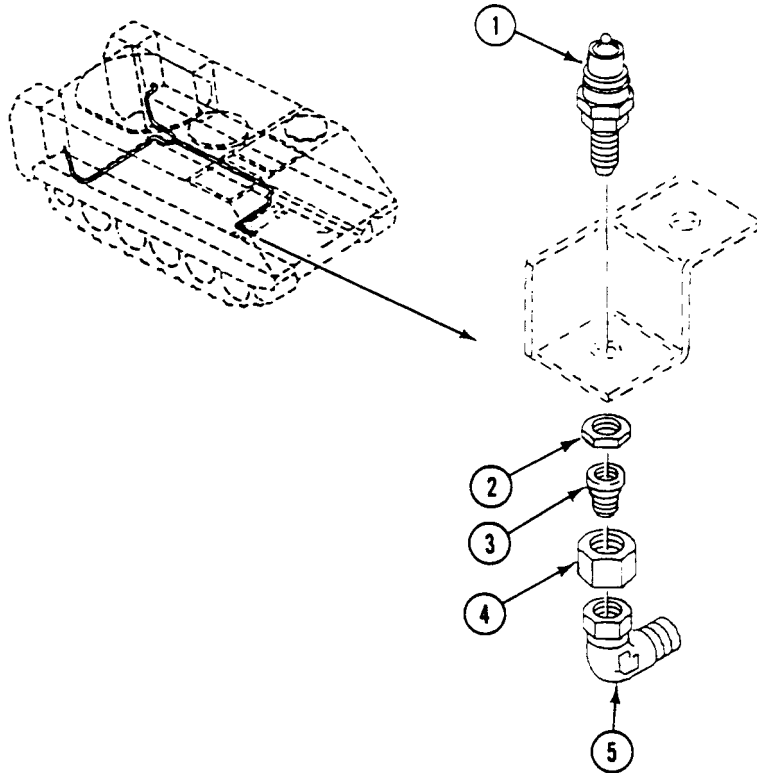

**REPLACE FUEL RETURN HOSES, TUBES, AND FITTINGS (M1064A3 ONLY) —
Continued**

0197 00

41. Install new grommet (2) on fuel return hose (3) and secure through bulkhead.
42. Connect fuel return hose (3) to elbow (4).
43. Connect quick-disconnect (1) to coupler nose (5).

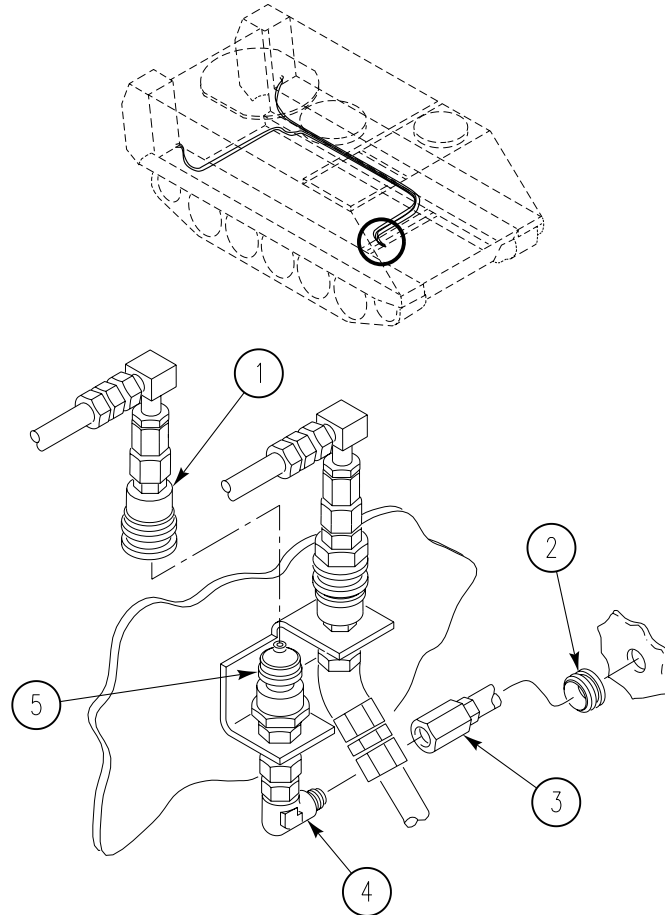

FOLLOW-THROUGH STEPS

1. Fill fuel tanks (see your -10).
2. Connect battery ground strap (see your -10).
3. Start engine (see your -10). Check for leaks.
4. Check for leaks in fuel lines.
5. Stop engine (see your -10).
6. Install power plant rear access panel (see your -10).
7. Install rear floor plates (WP 0543 00).
8. Install heater duct (WP 0706 00).
9. Start engine (see your -10).
10. Raise and lock ramp (see your -10).
11. Stop engine (see your -10).

END OF TASK

REPLACE FUEL VENT HOSES, TUBES, AND FITTINGS (M577A3 AND M1068A3 ONLY)

0198 00

THIS WORK PACKAGE COVERS:

Removal (page 0198 00-1).
 Installation (page 0198 00-4).

INITIAL SETUP:

Maintenance Level

Unit

References

See your -10

Tools and Special Tools

General Mechanic's Tool Kit (WP 0926 00, Item 65)

Equipment Condition

Engine stopped (see your -10)
 Carrier blocked (see your -10)
 Ramp lowered (see your -10)
 Battery ground lead disconnected (WP 0338 00)
 Map board removed (see your -10)
 Work tables removed (WP 0578 00)
 or (WP 0581 00 and WP 0582 00)

Materials/Parts

Sealing compound (WP 0928 00, Item 56)
 Lockwasher (17)
 Suitable container

Personnel Required

Unit Mechanic

REMOVAL

1. Drain fuel tanks below level of vent hoses (WP 0178 00).
2. Disconnect vent hose (1) from elbow (2).
3. Disconnect vent hose (3) from elbow (4).

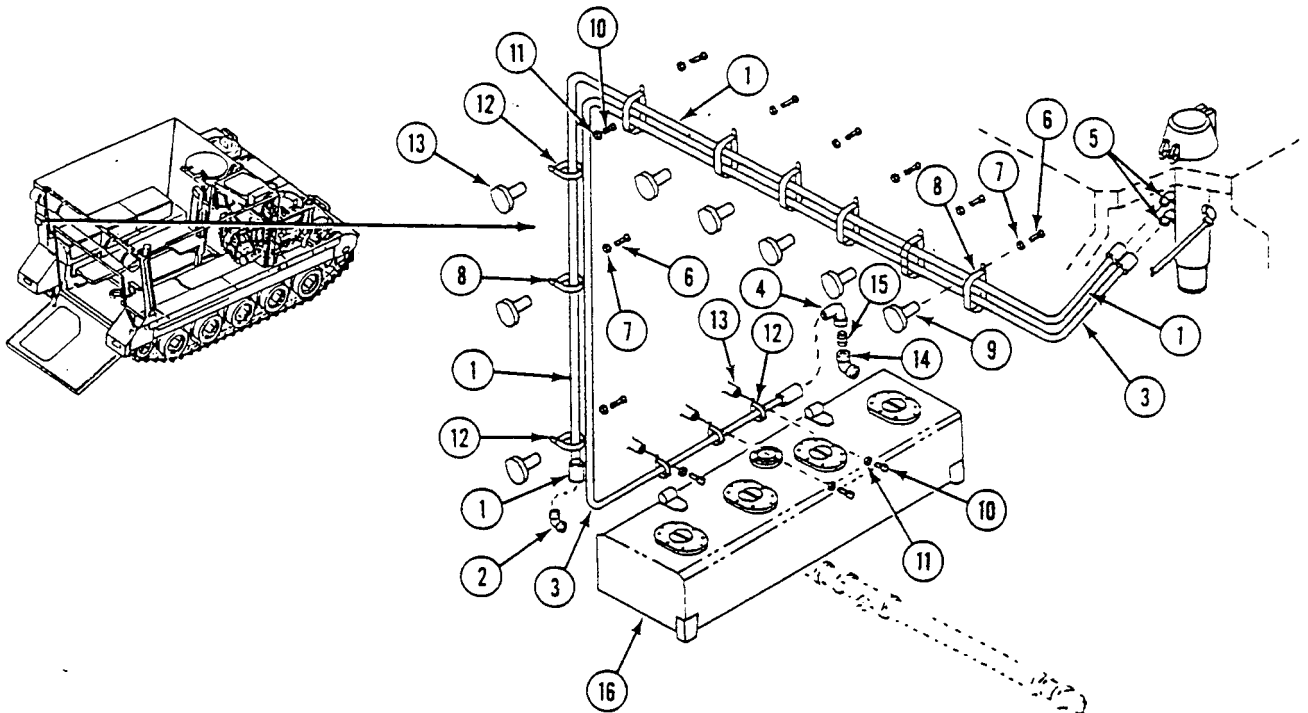

REPLACE FUEL VENT HOSES, TUBES, AND FITTINGS (M577A3 AND M1068A3 ONLY)

0198 00

— Continued

4. Disconnect vent hoses (1) and (3) from two elbows (5).
5. Remove seven screws (6), lockwashers (7), clamps (8), and vent hoses (1) and (3) from seven weldnuts (9). Discard lockwashers.
6. Remove five screws (10), lockwashers (11), clamps (12), and vent hoses (1) and (3) from five weldnuts (13). Discard lockwashers.
7. Remove three elbows (2), (4), and (14) and nipple (15) from left fuel tank (16).

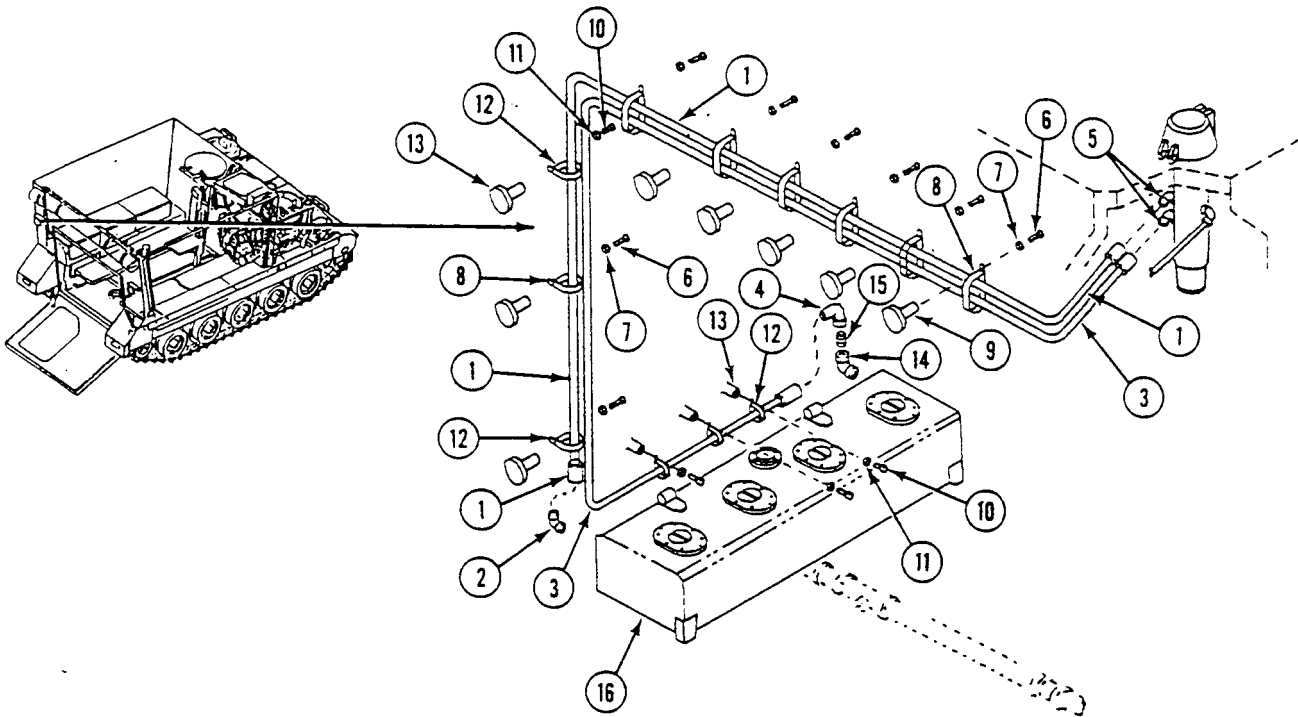

REPLACE FUEL VENT HOSES, TUBES, AND FITTINGS (M577A3 AND M1068A3 ONLY)
— Continued

0198 00

8. Disconnect vent tube (1) from two elbows (2) and (3).
9. Remove five screws (4), lockwashers (5), clamps (6), and vent tube (1) from five weldnuts (7). Discard lockwashers.
10. Remove two elbows (8) and elbow (2) from filler neck (9).
11. Remove elbow (3) and bushing (10) from right fuel tank (11).

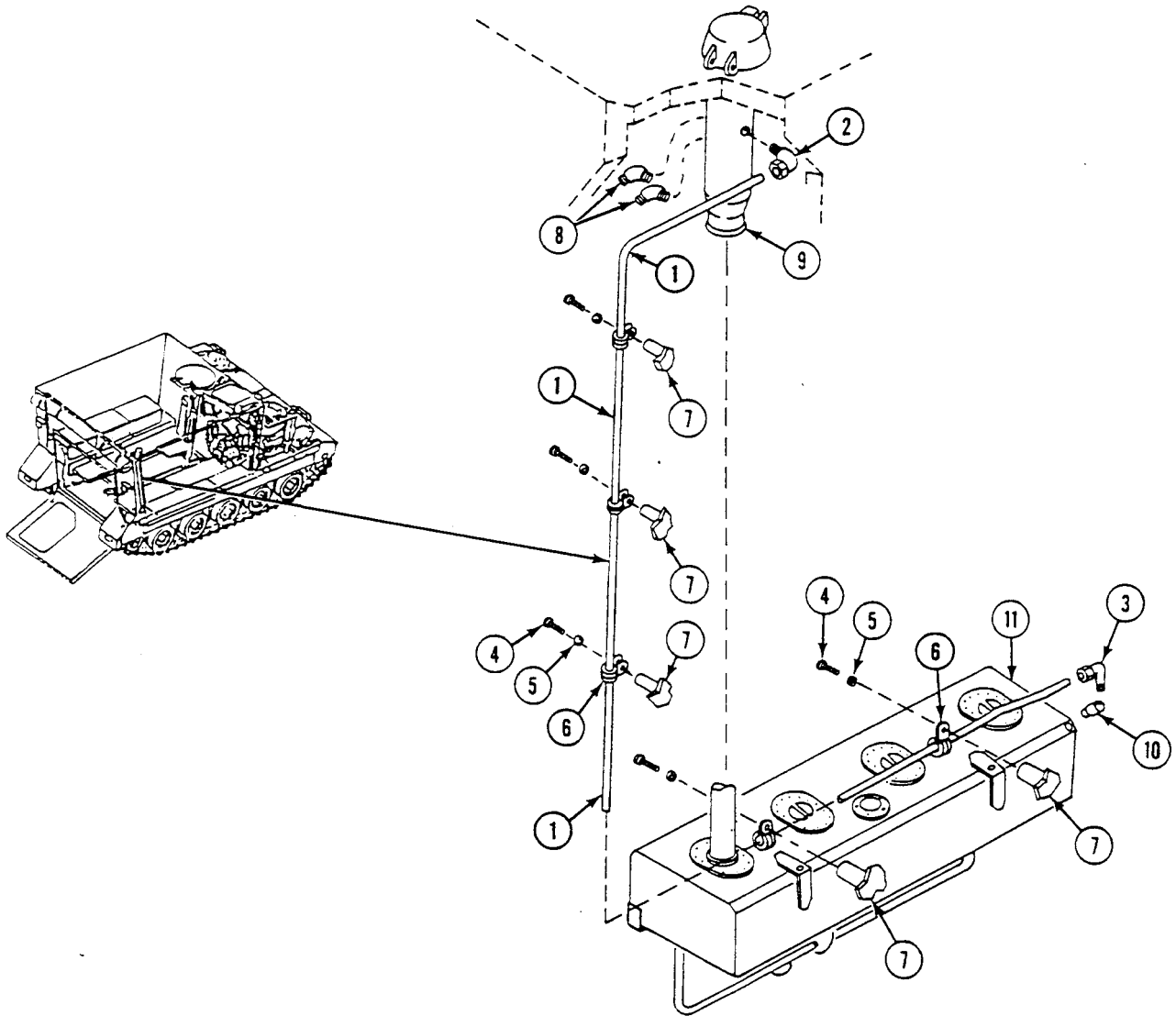

REPLACE FUEL VENT HOSES, TUBES, AND FITTINGS (M577A3 AND M1068A3 ONLY)

0198 00

— Continued

INSTALLATION

1. Apply a thin, even coat of sealing compound to cleaned external threads of fittings.
2. Install bushing (10) in right fuel tank (11).
3. Install elbow (3) on bushing (10).
4. Install two elbows (8) and elbow (2) in filler neck (9).
5. Connect vent tube (1) to two elbows (2) and (3).
6. Install vent tube (1) on five weldnuts (7). Secure with five clamps (6), new lockwashers (5), and screws (4).

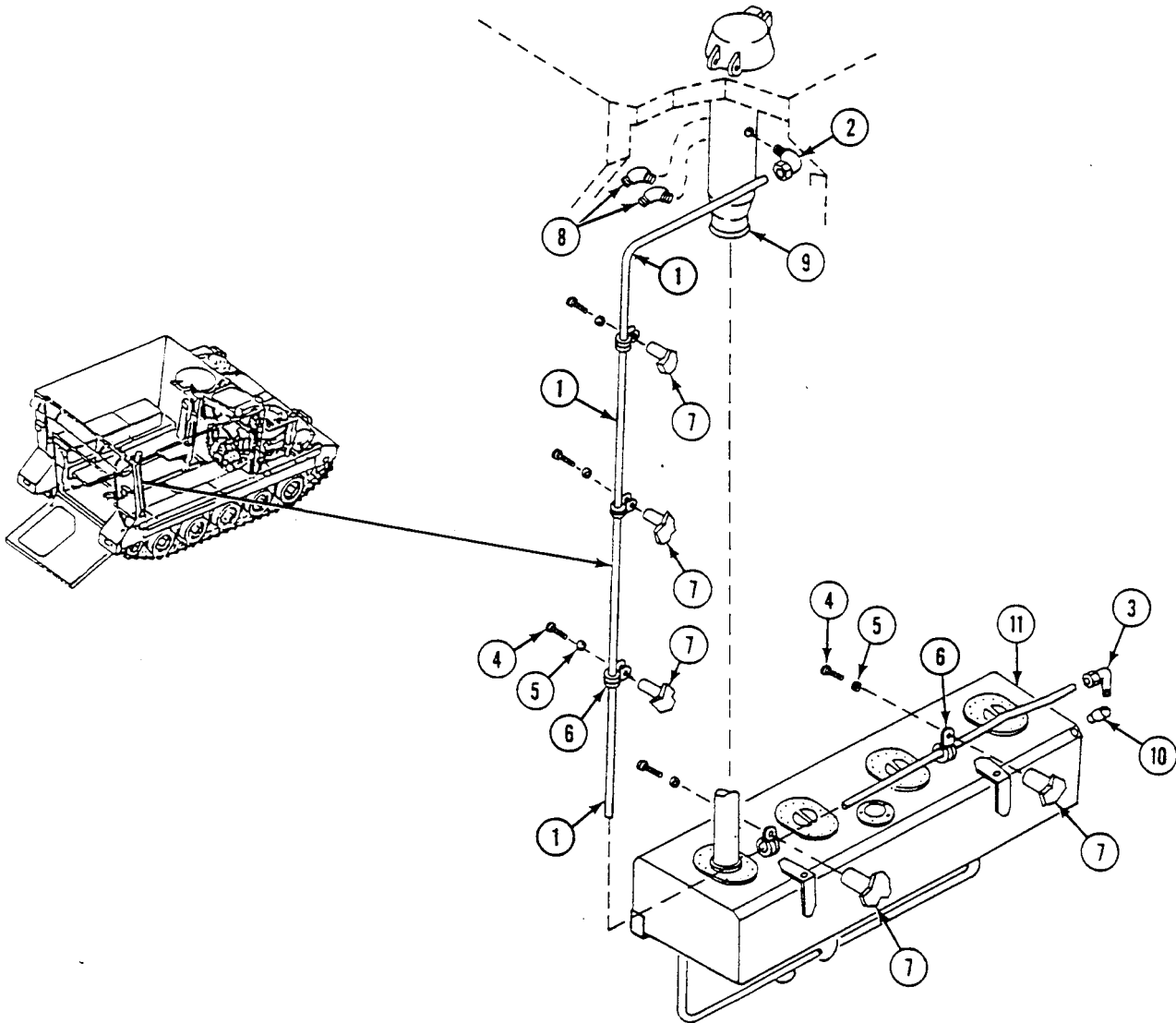

REPLACE FUEL VENT HOSES, TUBES, AND FITTINGS (M577A3 AND M1068A3 ONLY)

0198 00

— Continued

7. Install two elbows (1) and (2) in left fuel tank (3).
8. Install nipple (4) in elbow (2).
9. Install elbow (5) on nipple (4).
10. Connect vent hose (6) to elbow (1) at left fuel tank (3).
11. Connect vent hose (7) to elbow (5) at left fuel tank (3).
12. Connect two vent hoses (6) and (7) to two elbows (8) at filler neck (9).
13. Install two vent hoses (6) and (7) on seven weldnuts (10). Secure with seven clamps (11), new lockwashers (12), and screws (13).
14. Secure vent hose (7) to five weldnuts (14) with five clamps (15), new lockwashers (16), and screws (17).

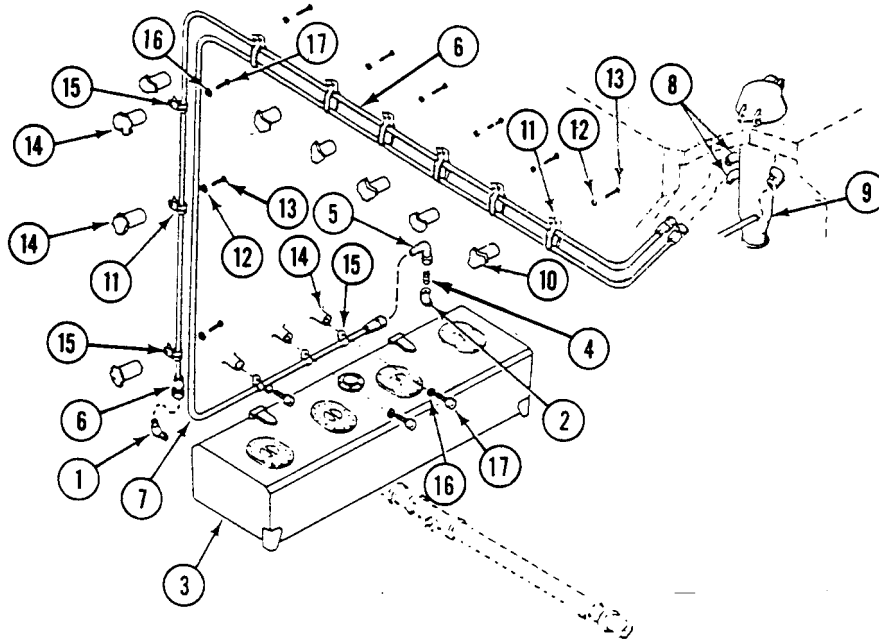

FOLLOW-THROUGH STEPS

1. Fill fuel tanks (see your -10). Check for leaks.
2. Install map board (see your -10).
3. Install work tables (WP 0578 00) or (WP 0581 00 and WP 0582 00).
4. Connect battery ground lead (WP 0338 00).
5. Start engine (see your -10).
6. Raise and lock ramp (see your -10).
7. Stop engine (see your -10).

END OF TASK

REPLACE FUEL VALVE MOUNTING BLOCKS (ALL EXCEPT M577A3 AND M1068A3)

0199 00

THIS WORK PACKAGE COVERS:

Removal (page 0199 00-1).
 Installation (page 0199 00-3).

INITIAL SETUP:

Maintenance Level

Unit

References

See your -10

Tools and Special Tools

General Mechanic's Tool Kit (WP 0926 00, Item 65)

Equipment Condition

Engine stopped (see your -10)
 Carrier blocked (see your -10)
 Ramp lowered (see your -10)

Personnel Required

Unit Mechanic

REMOVAL

NOTE

Right and left side mounting blocks are replaced the same way. Left side is shown.

1. Remove two screws (1) and washers (2) securing three clamps and fuel shutoff valves (3) and (4) to mounting block (5).

REPLACE FUEL VALVE MOUNTING BLOCKS (ALL EXCEPT M577A3 AND M1068A3) —
Continued

0199 00

2. Remove screw (6), washer (7), and mounting block (5) from side of sponson.

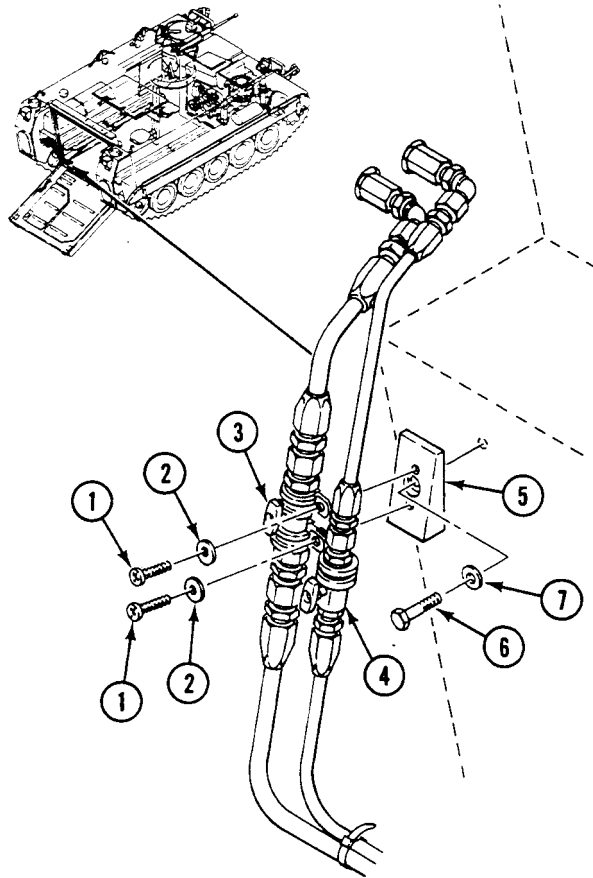

REPLACE FUEL VALVE MOUNTING BLOCKS (ALL EXCEPT M577A3 AND M1068A3) —
Continued

0199 00

INSTALLATION

1. Install mounting block (5) on side of sponson and secure with washer (7) and screw (6).
2. Secure three clamps and fuel shutoff valves (4) and (3) to mounting block (5) with two washers (2) and screws (1).

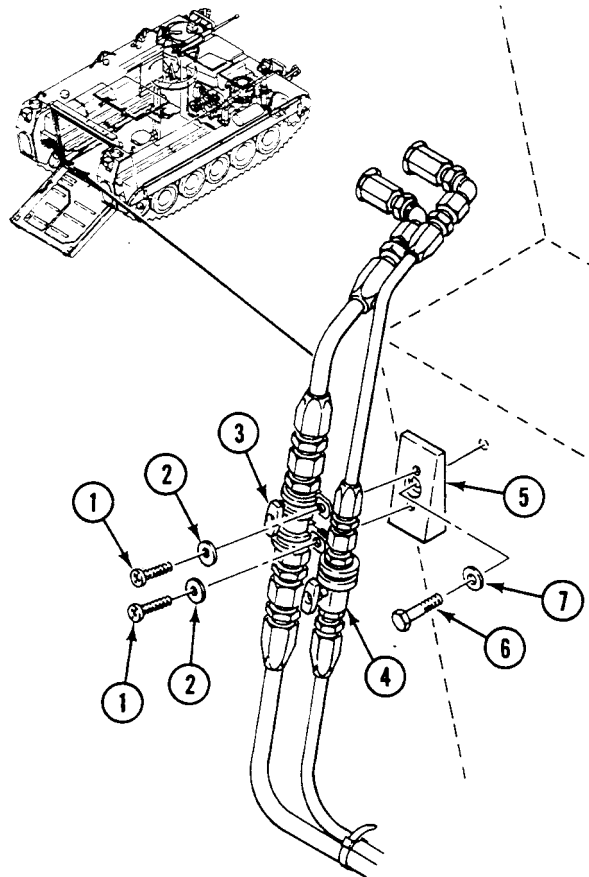
**FOLLOW-THROUGH STEPS**

1. Start engine (see your -10).
2. Raise and lock ramp (see your -10)
3. Stop engine (see your -10).

END OF TASK

REPLACE ENGINE FUEL SUPPLY HOSE

0200 00

THIS WORK PACKAGE COVERS:

- Removal (page 0200 00-1).
- Installation (page 0200 00-3).

INITIAL SETUP:

Maintenance Level

Unit

Tools and Special Tools

General Mechanic's Tool Kit (WP 0926 00, Item 65)

Materials/Parts

- Sealing compound (WP 0928 00, Item 56)
- Suitable container
- Tie strap

Personnel Required

- Unit Mechanic
- Helper (H)

References

See your -10

Equipment Condition

- Engine stopped (see your -10)
- Carrier blocked (see your -10)
- Power plant rear access panels removed (see your -10)
- Driver's compartment access panel removed (see your -10)
- Power plant access door open (see your -10)
- Battery ground strap disconnected (WP 0337 00), (WP 0338 00), or (WP 0339 00)
- Air intake elbow removed (WP 0173 00)
- Exhaust elbow removed (WP 0221 00)

REMOVAL

1. Disconnect coupler nose (1) from coupler body (2).

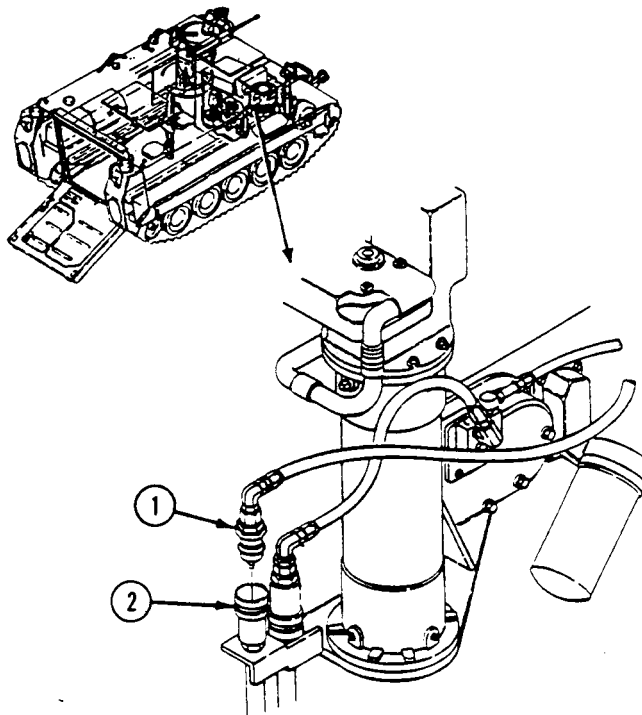

- Remove tie strap (3) from fuel hoses (4) and (5). Discard strap.

NOTE

Use suitable container to catch fuel leakage.

- Disconnect fuel supply hose (4) from elbow (6) on primary fuel filter.

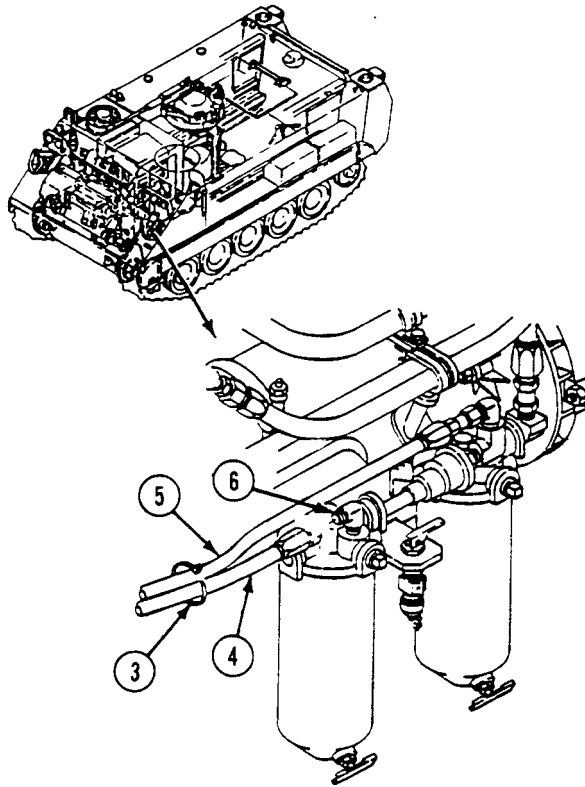
**NOTE**

Note position of fuel supply hose in relation to power plant before removing hose.

- Remove fuel supply hose (1) from carrier. Have helper assist.

5. Disassemble fuel supply hose (1) from elbow (2) on coupler nose (8).

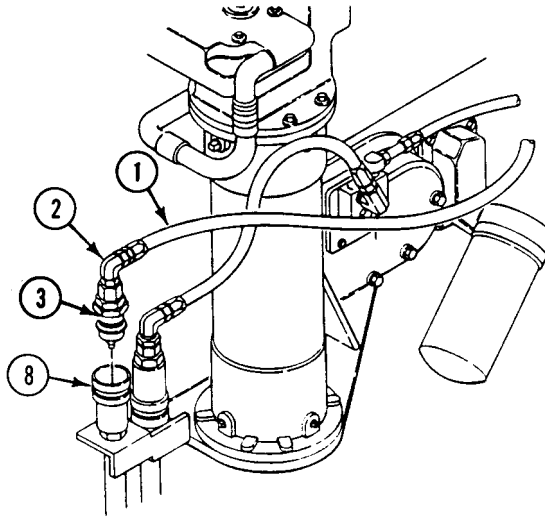

INSTALLATION

NOTE

Do Step 1 before installing fuel supply hose in carrier.

1. Assemble fuel supply hose (1) to elbow (2) on coupler nose (8).

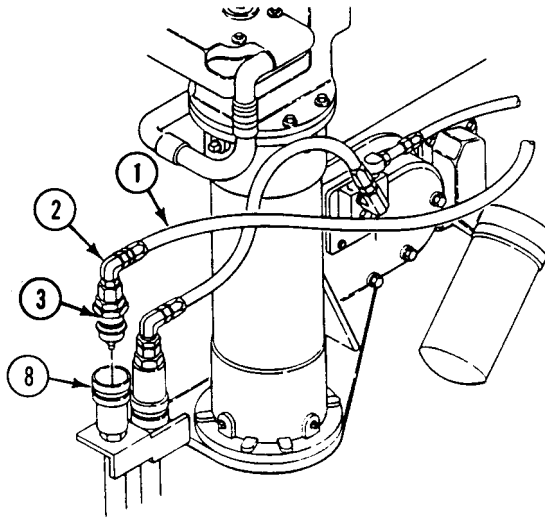

NOTE

Make sure routing of fuel supply hose is the same as it was before removal.

2. Install fuel supply hose (1) in carrier. Have helper assist.
3. Apply sealing compound to threads of elbow (4) on primary fuel filter (5).
4. Connect fuel supply hose (1) to elbow (4).
5. Secure fuel lines (1)(6) with new tie strap (7).
6. Connect coupler nose (1) to coupler body (2).

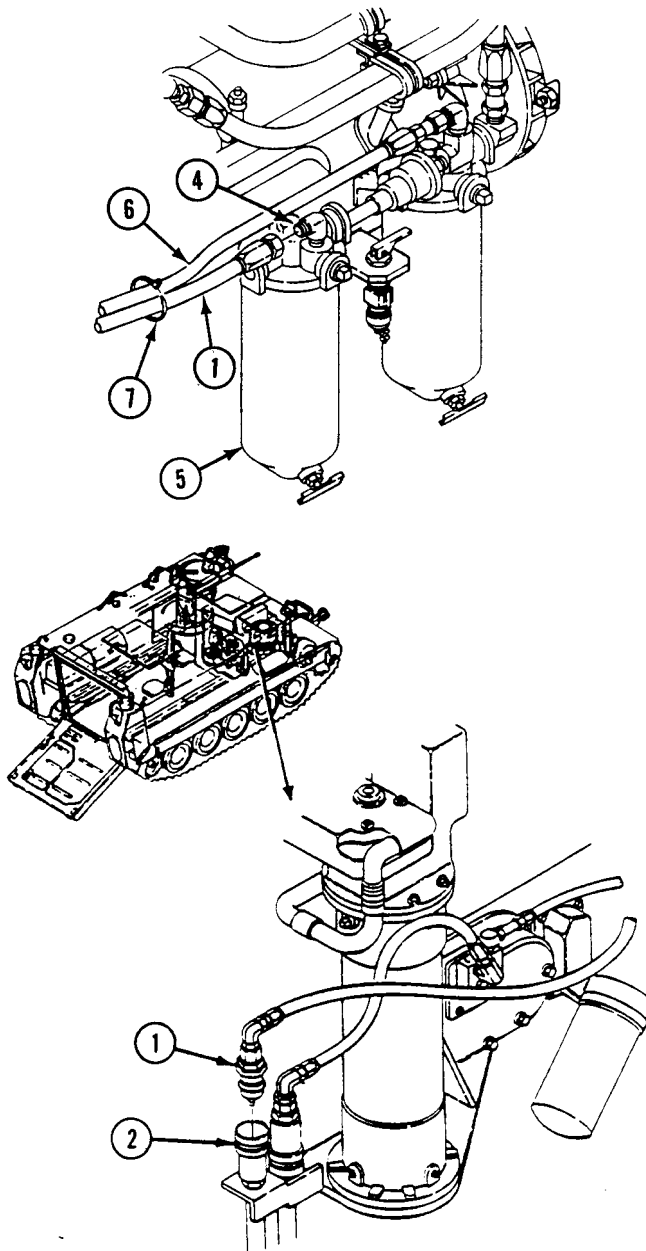

FOLLOW-THROUGH STEPS

1. Install exhaust elbow (WP 0221 00).
2. Install air intake elbow (WP 0173 00).
3. Connect battery ground strap (WP 0337 00), (WP 0338 00), or (WP 0339 00).
4. Start engine (see your -10). Check for leaks.
5. Stop engine (see your -10).
6. Install driver's compartment access panel (see your -10).
7. Install power plant rear access panels (see your -10).
8. Close power plant access door (see your -10).

END OF TASK

REPLACE ENGINE FUEL RETURN HOSE

0201 00

THIS WORK PACKAGE COVERS:

Removal (page 0201 00-1).
 Installation (page 0201 00-3).

INITIAL SETUP:

Maintenance Level

Unit

Tools and Special Tools

General Mechanic's Tool Kit (WP 0926 00, Item 65)

Personnel Required

Unit Mechanic

References

See your -10

Equipment Condition

Engine stopped (see your -10)
 Carrier blocked (see your -10)
 Power plant rear access panels removed (see your -10)
 Battery ground strap disconnected (WP 0337 00),
 (WP 0338 00), or (WP 0339 00)

REMOVAL

1. Disconnect coupler body (1) from coupler nose (2).
2. Disconnect fuel return hose (3) from elbow (4) on fuel manifold.

3. Disconnect fuel return hose (3) from elbow (5) on coupler body (1).

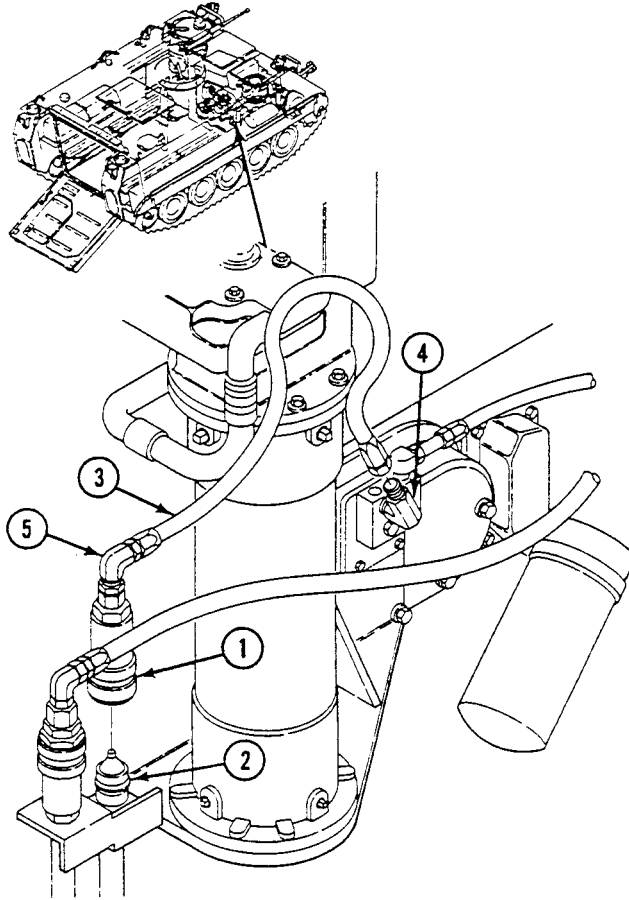

INSTALLATION

1. Connect fuel return hose (3) to elbow (5) on coupler body (1).
2. Connect fuel return hose (3) to elbow (4) on fuel manifold.
3. Connect coupler body (1) to coupler nose (2).

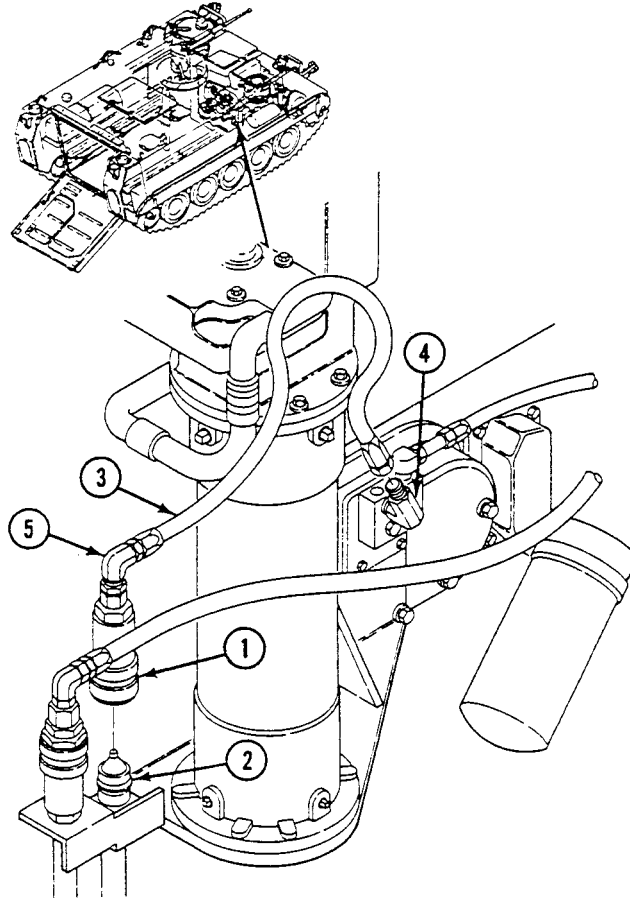
**FOLLOW-THROUGH STEPS**

1. Connect battery ground strap (WP 0337 00), (WP 0338 00), or (WP 0339 00).
2. Start engine (see your -10). Check for leaks. Stop engine.
3. Install power plant rear access panels (see your -10).

END OF TASK

REPLACE PRIMARY AND SECONDARY FUEL FILTER ELEMENTS

0202 00

THIS WORK PACKAGE COVERS:

Removal (page 0202 00-2).
 Installation (page 0202 00-5).

INITIAL SETUP:

Maintenance Level

Unit

Personnel Required

Unit Mechanic

Tools and Special Tools

General Mechanic's Tool Kit (WP 0926 00, Item 65)
 Crowfoot attachment, socket wrench, 3/4 inch
 (WP 0926 00, Item 16)

References

See your -10

Materials/Parts

Gasket (2)
 Container (quart)
 Primary filter kit
 Secondary filter kit
 Wiping rag (WP 0928 00, Item 65)

Equipment Condition

Engine stopped (see your -10)
 Carrier blocked (see your -10)
 Driver's power plant access panel
 removed (see your -10)
 Fuel supply and return valves turned off (see your -10)

REMOVAL

1. Place container under drain cock (1). Open drain cock and drain fuel from fuel filter. Close drain cock. Repeat procedures on drain cock (10) of secondary fuel filter, if replacing both filters.

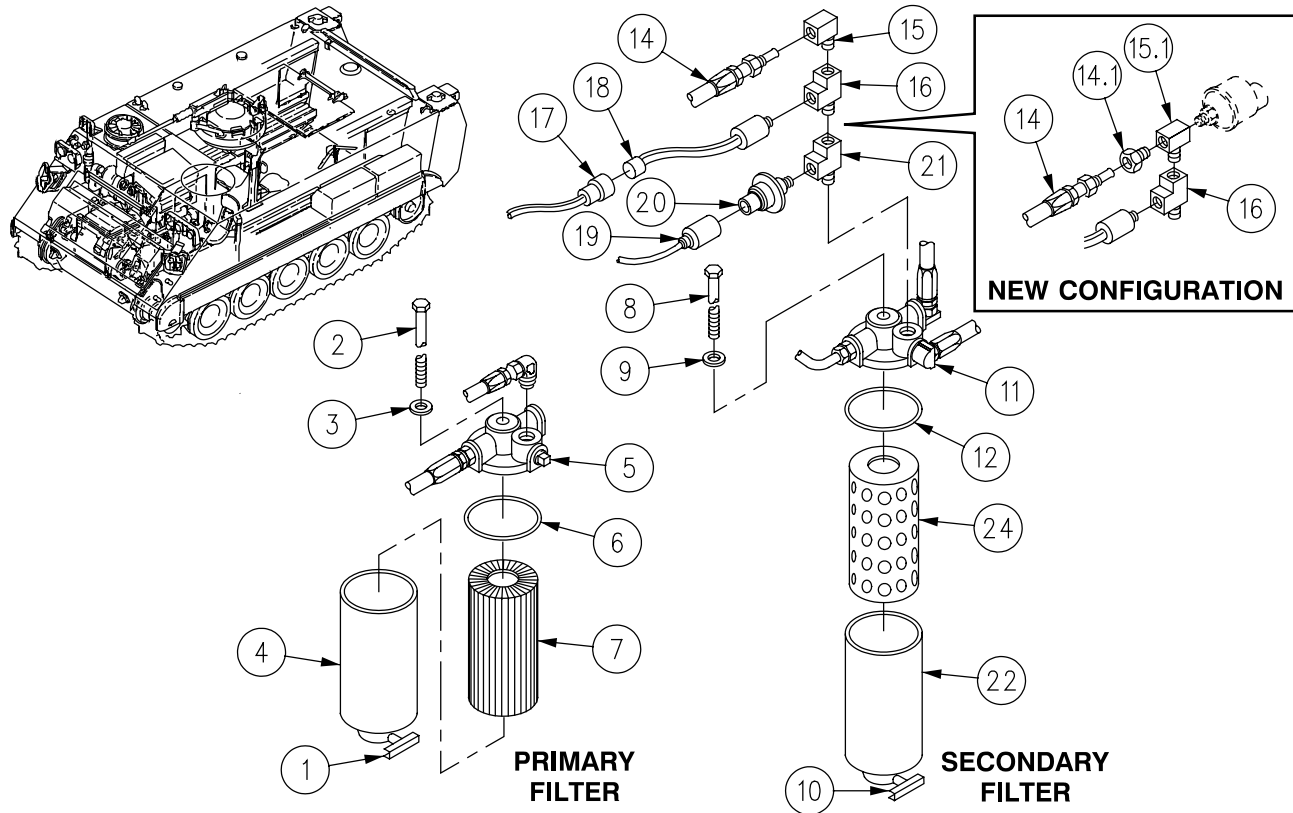

NOTE

Install covers on disconnected fuel lines, tubes, valves, and components during maintenance. Use tape, cloth, cardboard, or any appropriate material to prevent damage to components or accidental fuel spills.

If primary fuel filter element is being removed, skip Steps 4 - 10. If secondary fuel filter element is being removed, skip Step 2 and Step 3.

2. Hold primary filter canister (4) and remove screw (2) and washer (3) securing canister to fuel filter head (5).
3. Remove filter canister (4), gasket (6), and primary fuel filter element (7) from filter head (5). Discard filter element and gasket per local SOP. Use rags and wipe canister (4) clean. Discard rags per local SOP.

NOTE

If crowfoot can be used to loosen up and remove screw (8), skip Steps 6 - 14 as you do not have to remove the fuel transmitter, generator field switch, fuel hose and tees to remove the secondary filter element. If the tees, fuel transmitter, or generator field switch interfere, they will need to be removed or moved to gain access to the screw (8) securing the secondary filter housing to the filter head.

4. Using a 3/4 inch crowfoot with 5 inch extension, remove screw (8) and washer (9) securing secondary filter canister (22) to fuel filter head (11).
5. Remove filter canister (22), gasket (12) and secondary fuel filter element (24) from filter head (11). Discard filter element and gasket per local SOP. Use rags and wipe canister (22) clean. Discard rags per local SOP.

NOTE

New and Old Configuration refer to the Variable Speed Fan Drive Configurations.

6. Remove hose (14) from elbow (15) on secondary fuel filter head (11).
- 6.1 Remove hose (14) from adapter (14.1) (New Configuration).

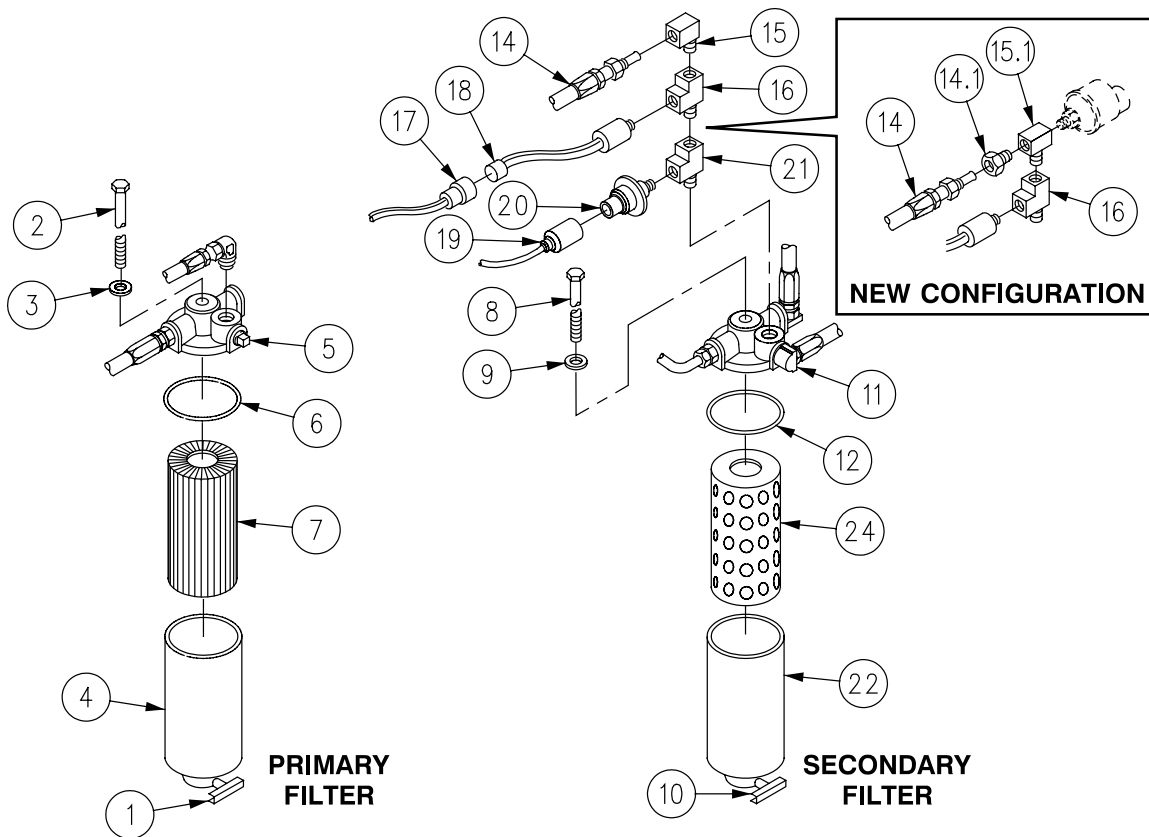

7. Remove elbow (15) from inlet tee (16) (Old Configuration).
- 7.1 Remove tee (15.1) from inlet tee (16) (New Configuration).
- 7.2 Remove adapter (14.1) from tee (15.1) (New Configuration).
8. Disconnect lead (17) from fuel pressure transmitter (18).
9. Remove fuel pressure transmitter (18) from inlet tee (16).
10. Disconnect lead (19) from generator field switch (20).
11. Remove generator field switch (20) from inlet tee (21).

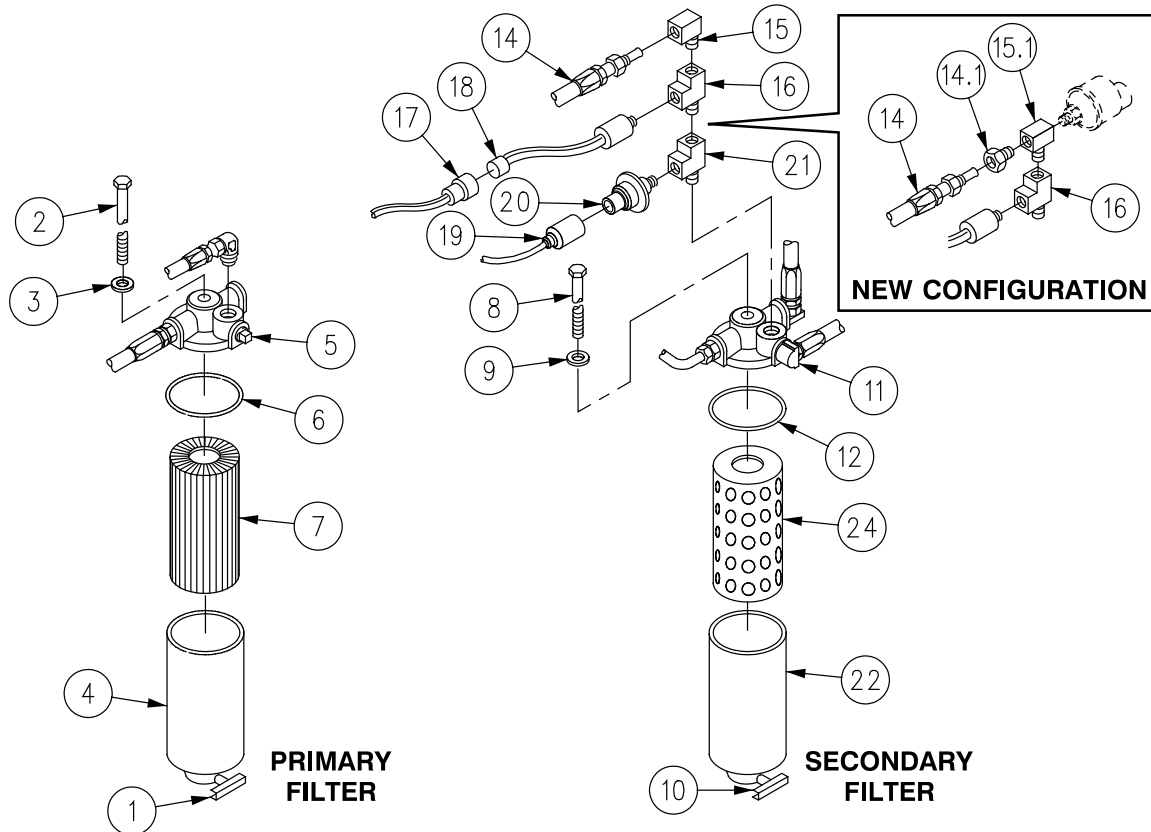

CAUTION

The two tees (16) and (21) and elbow (15) are made of brass and will damage easily if, during removal, the switch, transmitter, or hose are removed. Put a bolt or switch back in the tee when turning it. This will prevent it from collapsing.

12. If required to gain access, remove two inlet tees (16) and (21) from secondary fuel filter head (11).
13. Hold filter canister (22) and remove screw (8) and washer (9) securing canister to fuel filter head (11).
14. Remove filter canister (22), gasket (12), and filter element (24) from filter head (11). Discard filter element. Wipe canister (22) clean. Use rags. Discard filter, gasket, and rags per local SOP.

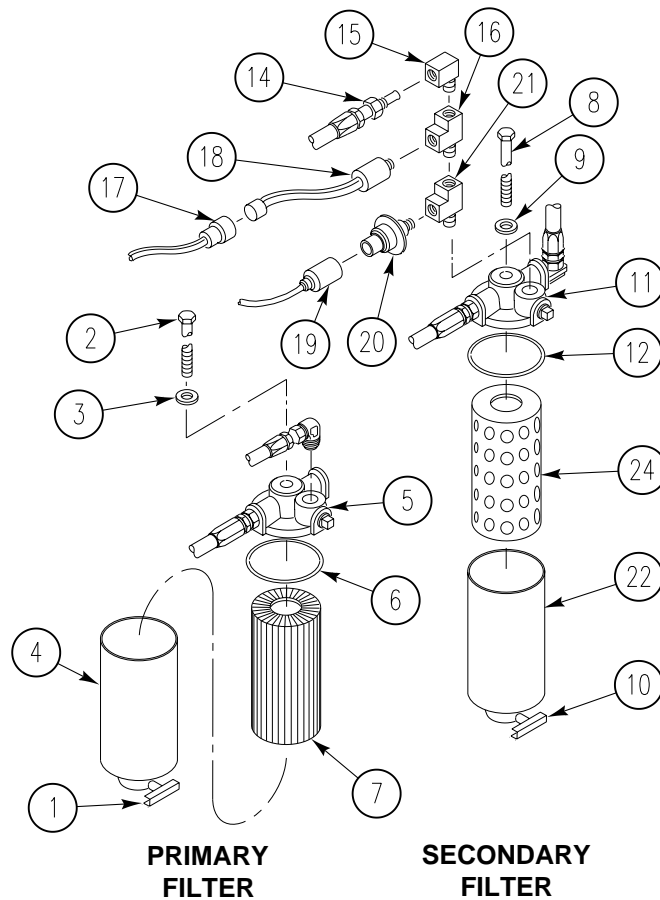

INSTALLATION**NOTE**

If secondary fuel filter element is being installed do Steps 1 - 10.

If primary fuel filter element is being installed do Steps 11 - 13.

1. Install new gasket (12) in filter head (11).
2. Install new filter element (24) in canister (22). Fill canister with fuel.

NOTE

Do not allow canister to turn when tightening screw. Damage to gasket can result.

3. Install canister (22) with filter element (24) on filter head (11). Secure with washer (9) and screw (8).
4. Install two inlet tees (16) and (21) on secondary fuel filter head (11).
5. Install generator field switch (20) on inlet tee (21).
6. Install fuel pressure transmitter (18) on inlet tee (16).
7. Connect lead (19) to generator field switch (20).
8. Connect lead (17) to fuel pressure transmitter (18).

9. Install elbow (15) on inlet tee (16) (Old Configuration).
- 9.1 Apply thin coat of sealing compound to male threads on tee (15.1). Install tee (15.1) on inlet tee (16) (New Configuration).
10. Connect hose (14) to elbow (15) on secondary fuel filter head (11) (Old Configuration).
- 10.1 Apply thin coat of sealing compound to male threads on adapter (14.1). Install adapter (14.1) on tee (15.1) (New Configuration).
- 10.2 Install hose (14) on adapter (14.1) (New Configuration).
11. Install new gasket (6) in filter head (5).
12. Install new primary fuel filter element (7) in canister (4). Fill canister with fuel.
13. Install canister (4) with filter element (7) on filter head (5). Secure with washer (3) and screw (2). Hold the canister (4) to prevent pushing the gasket out of place.

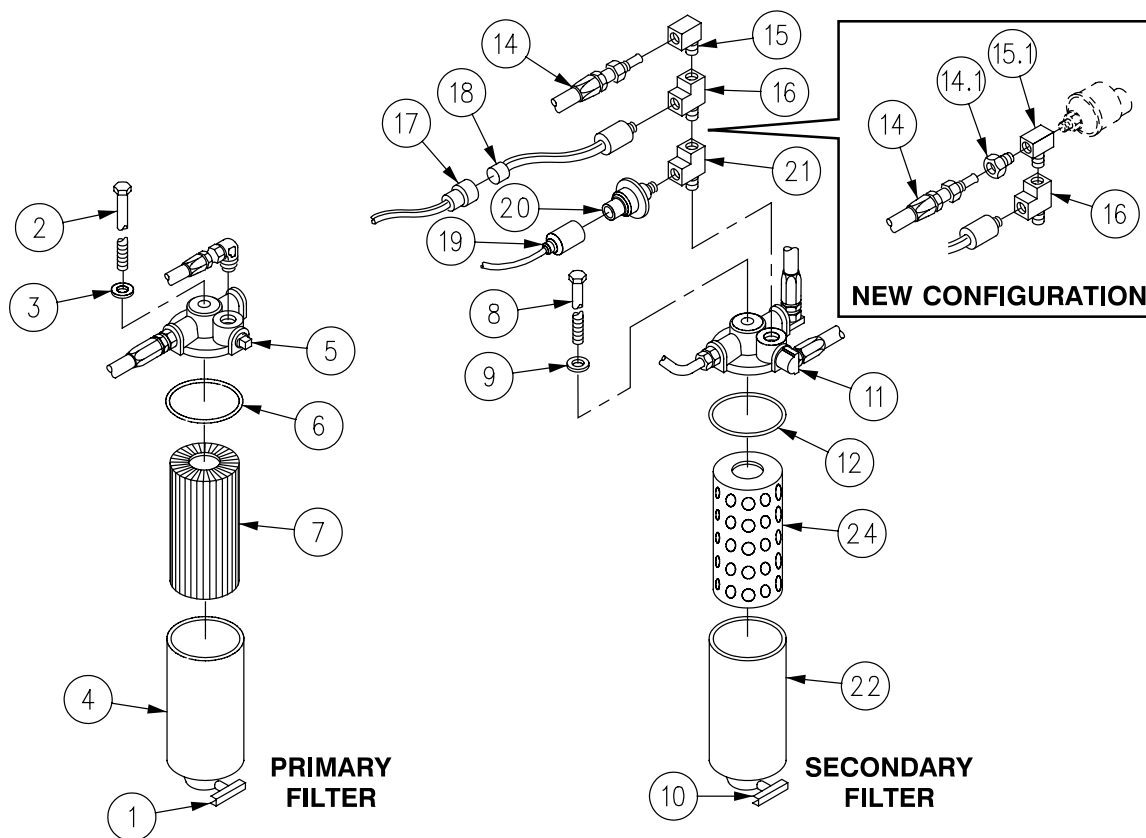

FOLLOW-THROUGH STEPS

1. Turn fuel supply and return valves on (see your -10).
2. Start engine (see your -10). Check for leaks. Stop engine (see your -10).
3. Install driver's compartment power plant access panel (see your -10).

END OF TASK

REPLACE PRIMARY AND SECONDARY FUEL FILTERS AND BRACKET

0203 00

THIS WORK PACKAGE COVERS:

Removal (page 0203 00-2).
 Installation (page 0203 00-3).

INITIAL SETUP:

Maintenance Level

Unit

References

See your -10

Tools and Special Tools

General Mechanic's Tool Kit (WP 0926 00, Item 65)

Equipment Condition

Carrier blocked (see your -10)
 Engine stopped (see your -10)
 Ramp lowered (see your -10)
 Master switch OFF (see your -10)
 Driver's power plant access panel
 removed (see your -10)
 Fuel tank shutoff valves closed (see your -10)
 Engine AOAP valve removed (WP 0163 00)
 Starter relay switch removed (WP 0258 00)

Materials/Parts

Locknut (4)
 Locknut (4)
 Sealing compound
 Wiping rag (WP 0928 00, Item 65)

Personnel Required

Unit Mechanic

REMOVAL

NOTE

New and Old Configuration refers to Variable Speed Fan Drive Configuration.

Install covers on disconnected fuel lines, tubes, valves, and components during maintenance. Use tape, cloth, cardboard, or any appropriate material to prevent damage to components or accidental fuel spills.

1. Remove hoses (1) from elbows (2). (New Configuration is a tee with adapter (7) instead of elbow (2).)
2. Remove hoses (6) and (3) from two adaptaters (5) and (4).

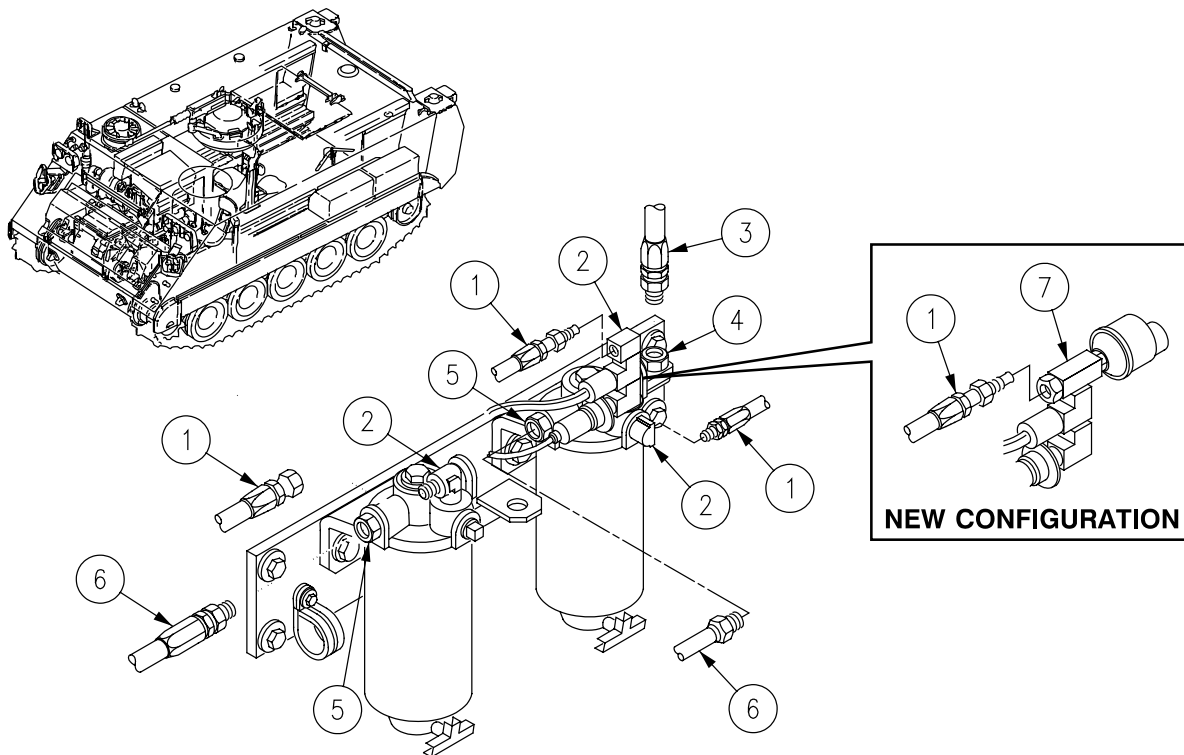

3. Remove screw (5), two washers (3), and clamp (4) from bracket (2).
4. Remove four screws (6), washers (7), locknuts (1), and bracket (2) from engine. Discard locknuts.

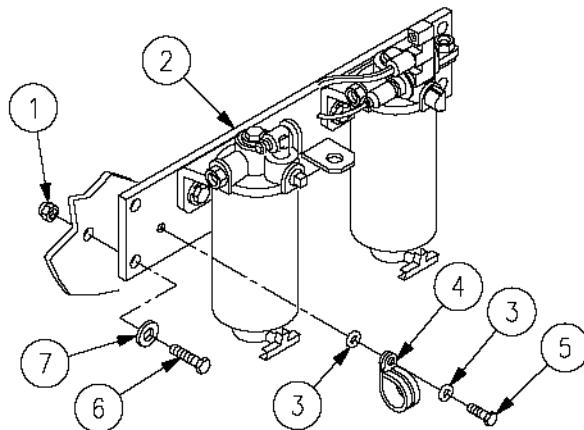

5. Remove four screws (9), washers (8), locknuts (1), and filters (10) from bracket (2). Discard locknuts.
6. Remove elbow (3) and adapters (11) from filter housings (6) and (7).
7. Remove elbows (5) and adapter (4) from filter housing (6).
8. Remove elbow (12), tee (13), and tee (14) from filter housing (6) (Old Configuration).
9. Remove tee with adapter and switch (15) (New Configuration).

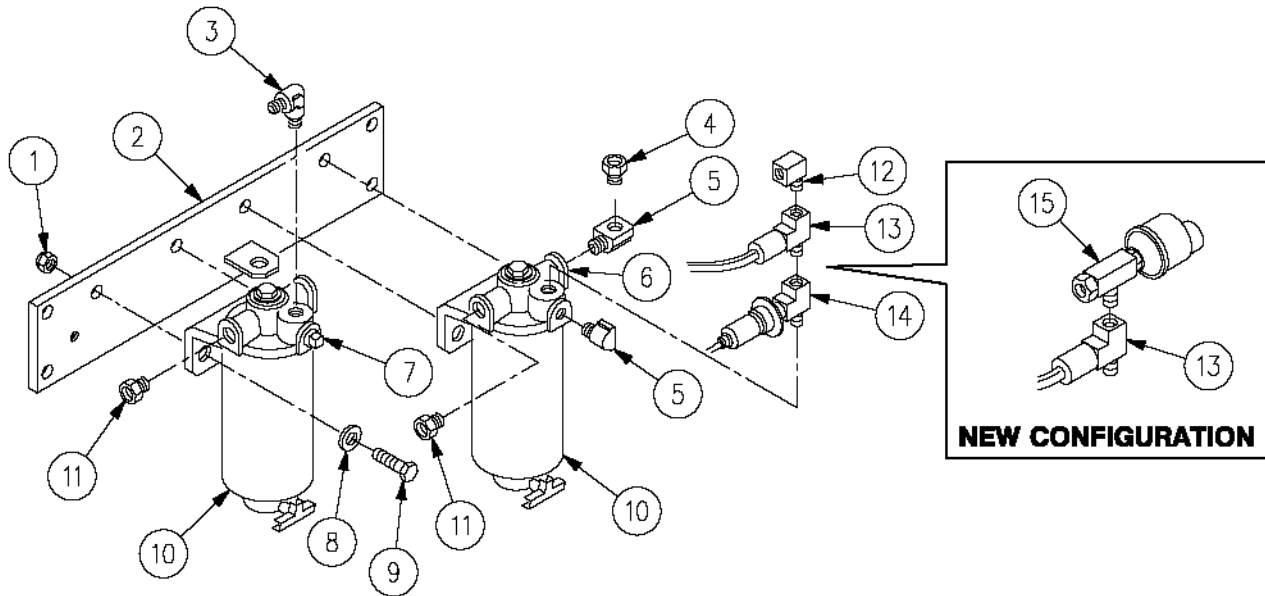

INSTALLATION

1. Install filters (3) on bracket (1). Secure with four screws (5), washers (4), and new locknuts (2).
2. Install clamp (8) on bracket (1) on engine. Secure with screw (6) and two washers (7).

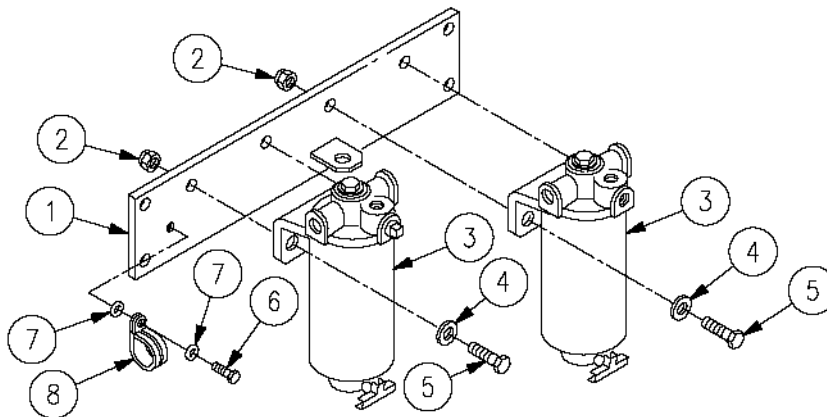

3. Install bracket (3) on engine (2). Secure with four screws (4), washers (5), and new locknuts (1).

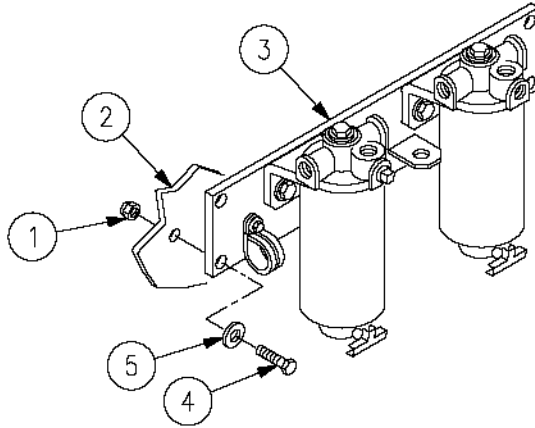

4. Apply thin coat of sealing compound to male tapered threads.
5. Install elbows (3) and adapter (2) on secondary filter housing (4).
- 5.1 Install elbow (7), tee (8) and tee (9) on secondary housing (4) (Old Configuration). Install tee with adapter and switch (10) to tee (8) (New Configuration).
6. Install elbow (1) and adapter (5) on primary filter housing (6).

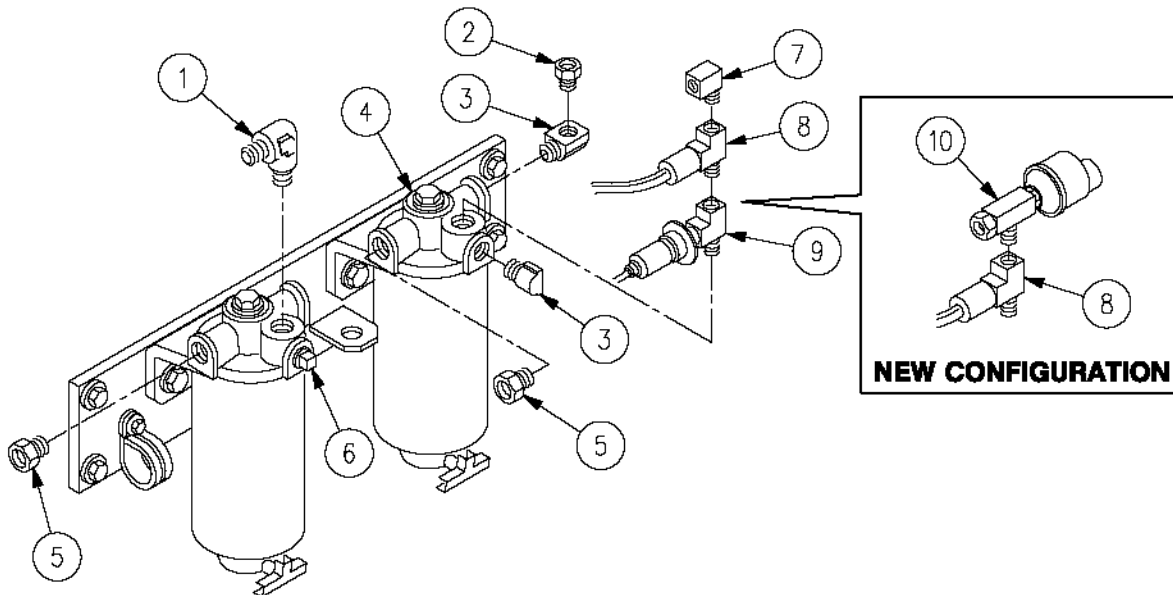

7. Install hoses (6) and (3) on two adapters (5) and adapter (4).
8. Install hose (1) on elbow (2) (Old Configuration).
9. Install hose (7) on tee (8). (New Configuration is a tee with adapter (8) instead of elbow (2).)

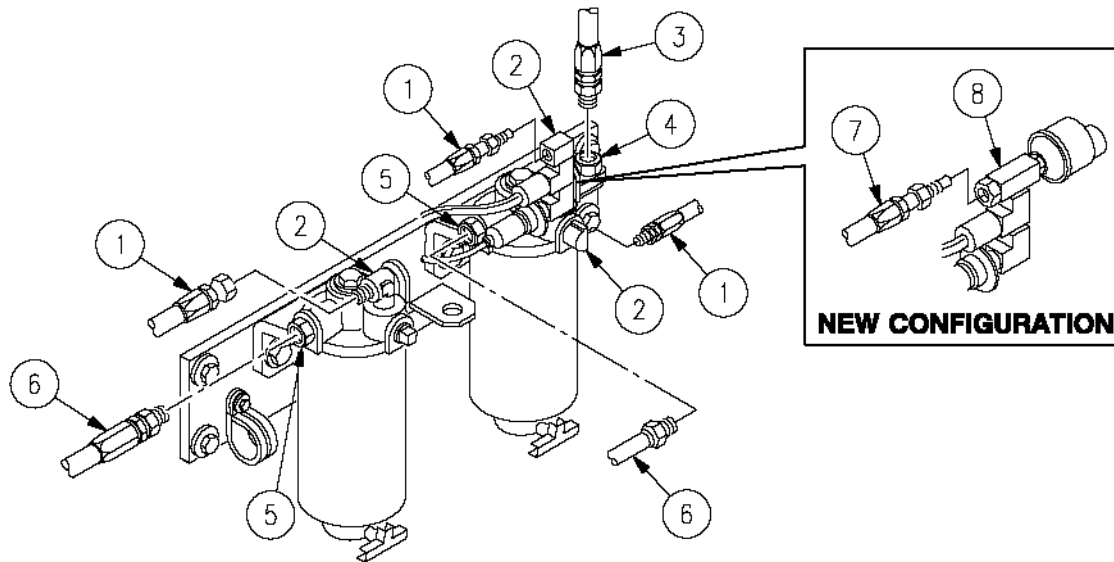

FOLLOW-THROUGH STEPS

1. Install engine AOAP valve (WP 0163 00).
2. Install starter relay switch (WP 0258 00).
3. Open fuel tank shutoff valves (see your -10).
4. Raise and lock ramp (see your -10).
5. Stop engine (see your -10).
6. Install driver's power plant access panel (see your -10).
7. Turn master switch OFF (see your -10).

END OF TASK

REPLACE AIR BOX HEATER IGNITION WIRE

0204 00

THIS WORK PACKAGE COVERS:

Removal (page 0204 00-1).
 Installation (page 0204 00-2).

INITIAL SETUP:

Maintenance Level

Unit

References

See your -10

Tools and Special Tools

General Mechanic's Tool Kit (WP 0926 00, Item 65)

Equipment Condition

Engine stopped (see your -10)

Carrier blocked (see your -10)

Materials/Parts

Tie strap (2)

Power plant upper and lower rear access panels and support removed (see your -10)

Personnel Required

Unit Mechanic

REMOVAL

1. Disconnect ignition wire (1) from air box igniter (2).
2. Remove two tie straps (3) from air pump wiring harness (4). Discard tie straps.
3. Disconnect other end of ignition wire (1) from ignition unit (5).
4. Loosen nut (6) and rotate solenoid receptacle (7) toward rear of carrier. Remove ignition wire (1).

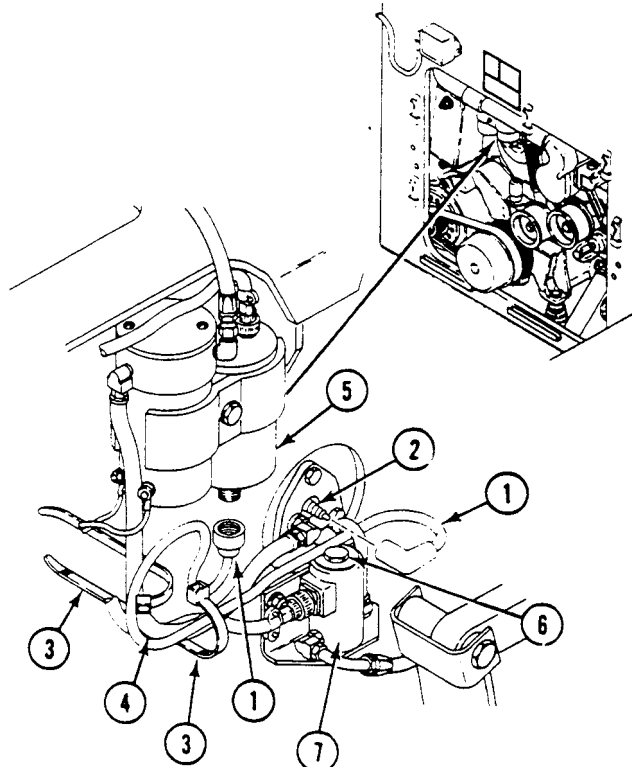

INSTALLATION

1. Connect ignition wire (1) to ignition unit (5).
2. Connect other end of ignition wire (1) to air box igniter (2).
3. Secure ignition wire (1) to air pump wiring harness (4) with two new tie straps (3).
4. Rotate solenoid receptacle (7) to original position. Tighten nut (6) 1/2 turn after contact.

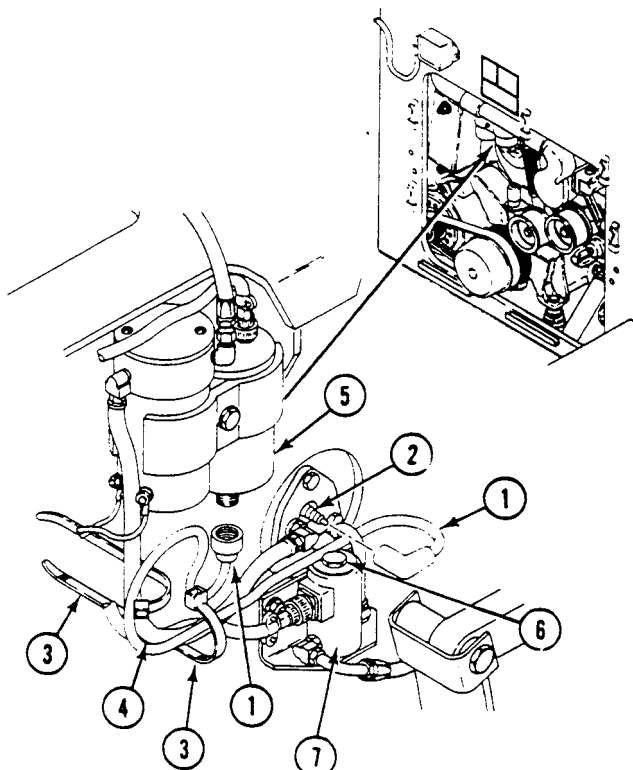
**FOLLOW-THROUGH STEPS**

1. Install power plant upper and lower rear access panels and support (see your -10).

END OF TASK

REPLACE AIR BOX HEATER WIRING HARNESS

0205 00

THIS WORK PACKAGE COVERS:

Removal (page 0205 00-1).
 Installation (page 0205 00-5).

INITIAL SETUP:

Maintenance Level

Unit

Personnel Required

Unit Mechanic

Tools and Special Tools

General Mechanic's Tool Kit (WP 0926 00, Item 65)

References

See your -10

Materials/Parts

Copper washer
 Lockwasher
 Tie strap (3)

Equipment Condition

Engine stopped (see your -10)
 Carrier blocked (see your -10)
 Power plant rear access panels
 and support removed (see your -10)

REMOVAL

NOTE

Hydraulic fluid reservoir is removed for clarity.

1. Loosen screw (1) and remove ignition coil (2). Disconnect lead (3) and lead (4) from ignition coil.

2. Remove screw (1), washer (5), two clamps (6) and three hoses (7) from engine.

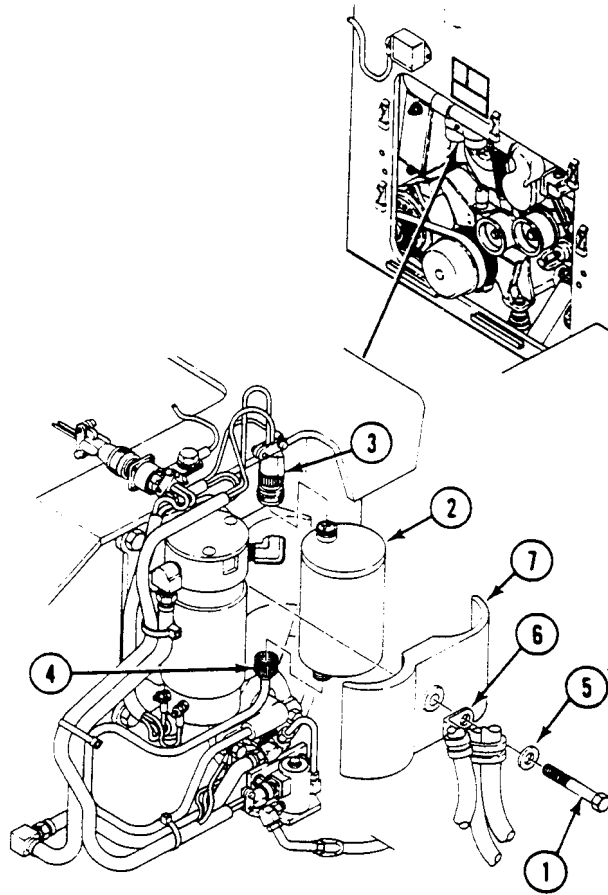

3. Disconnect engine wiring harness connector (1) from air box receptacle (2).
4. Remove screw (3), two washers (4), lockwasher (5), nut (6), ground lead (7), and clamp (8) from bracket (9). Discard lockwasher.

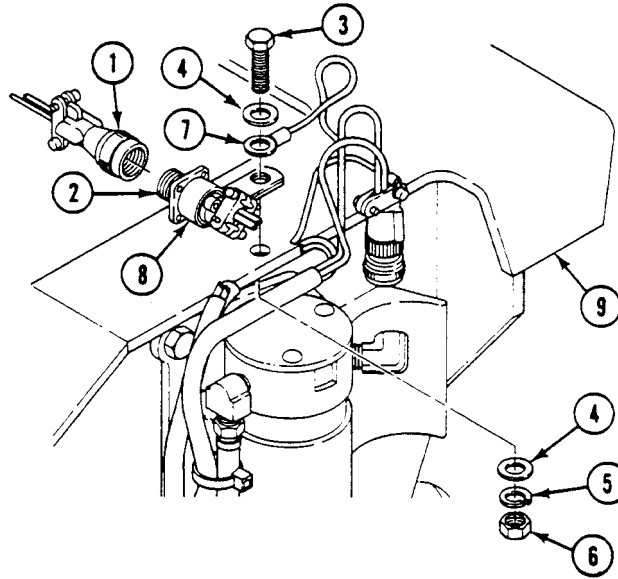

5. Remove three tie straps (10) from wiring harness (11) and air pump hose (12).

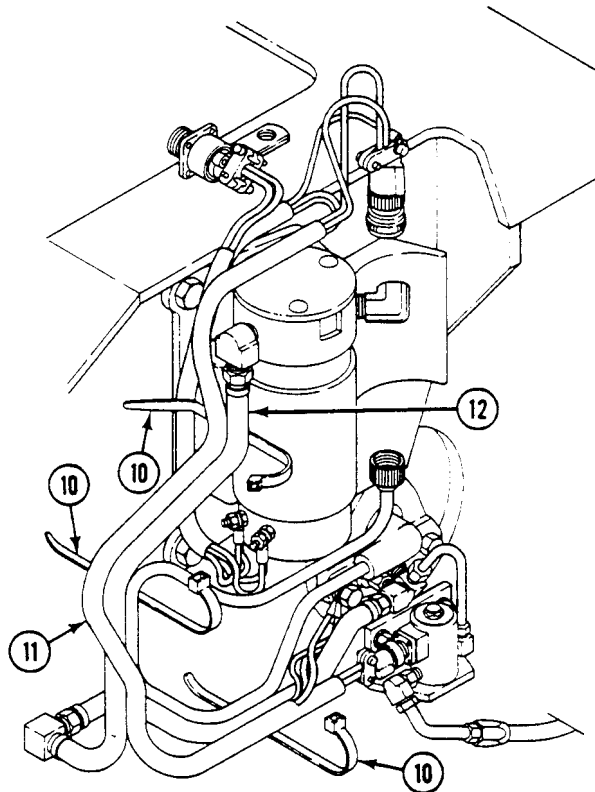

REPLACE AIR BOX HEATER WIRING HARNESS — Continued

0205 00

6. Remove nut (13) and lead (14) from air pump positive (+) terminal (15).
7. Remove nut (16) and lead (17) from air pump negative (-) terminal (18).

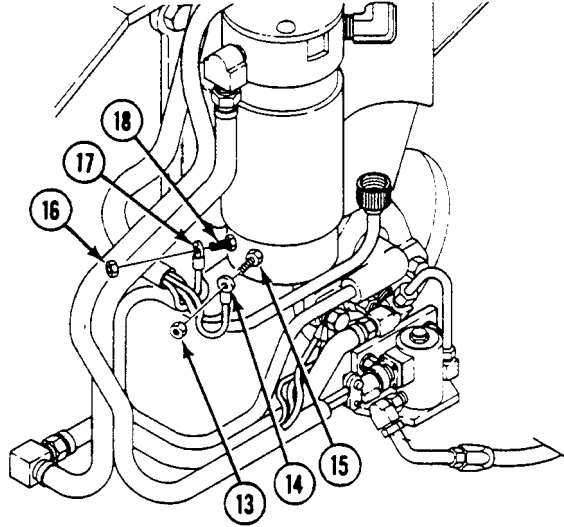

8. Disconnect wiring harness connector (19) from air box fuel solenoid (20).
9. Remove hose (21) from air box heater elbow (22).
10. Remove screw (23), copper washer (24) and three ground leads (25) from air box heater (26). Discard copper washer.

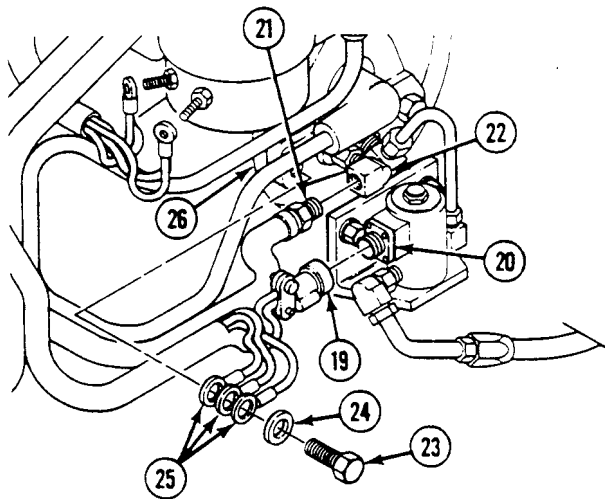

INSTALLATION

1. Install three ground leads (1) on air box heater (2). Secure with new copper washer (3) and screw (4).
2. Install hose (5) on air box heater elbow (6).
3. Connect wiring harness connector (7) to air box fuel solenoid (8).

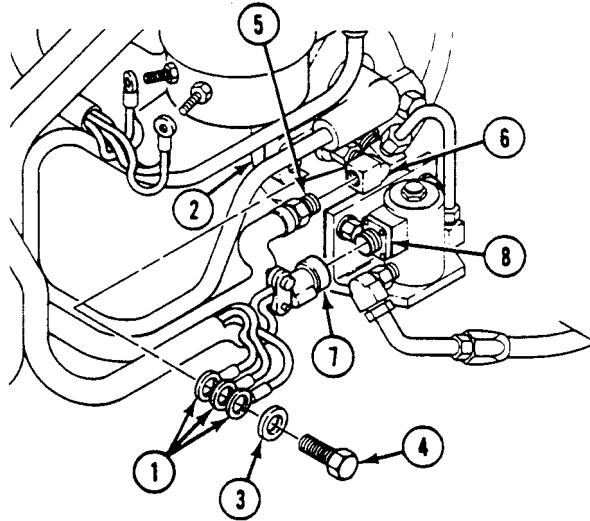

4. Install lead (9) on air pump negative (-) terminal (10). Secure with nut (11).
5. Install lead (12) on air pump positive (+) terminal (13). Secure with nut (14).

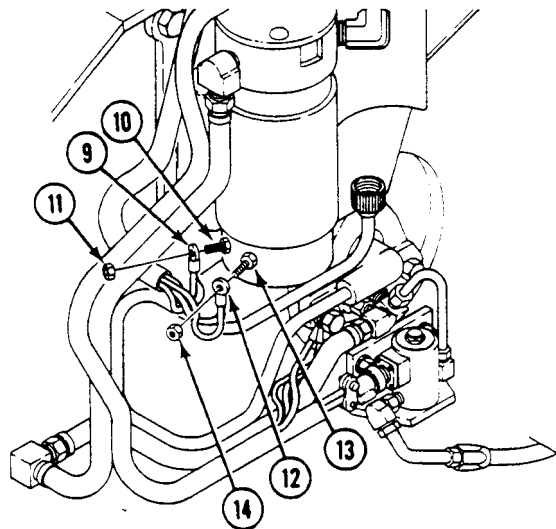

6. Fasten three new straps (15) to wiring harness (16) and air pump hose (17).

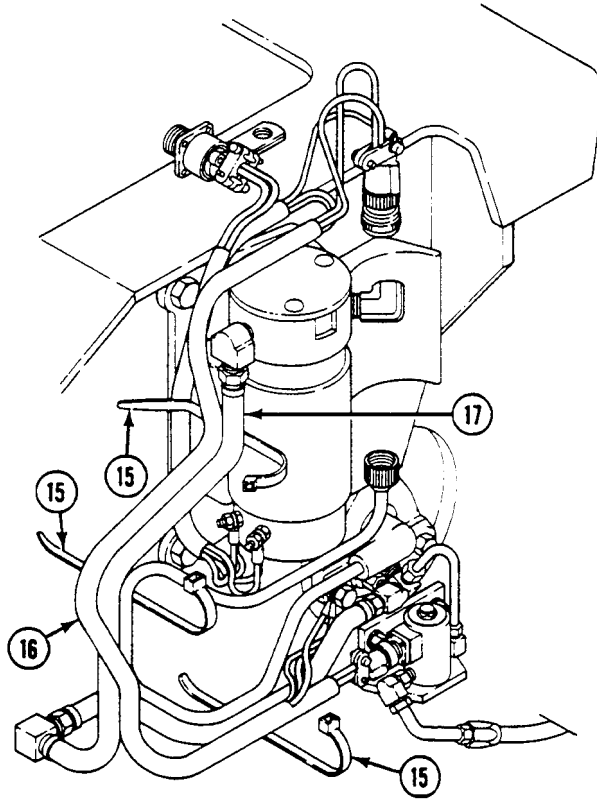

7. Install ground lead (18) and clamp (19) on bracket (20). Secure with screw (21), two washers (22), new lockwasher (23), and nut (24).
8. Connect engine wiring harness connector (25) to air box receptacle (26).

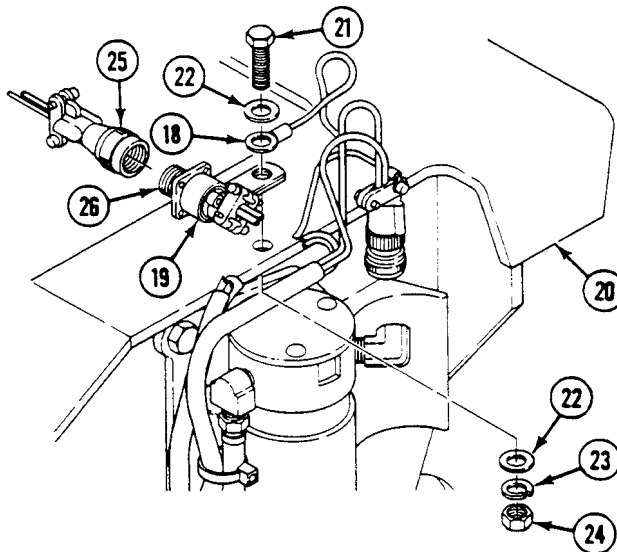

REPLACE AIR BOX HEATER WIRING HARNESS — Continued

0205 00

9. Install bracket (1) and two clamps with three hoses (2) on ignition coil (3). Secure with screw (4) and washer (5). Do not tighten screw.
10. Connect lead (6) and lead (7) to ignition coil (3). Install ignition coil on bracket (1). Tighten screw.

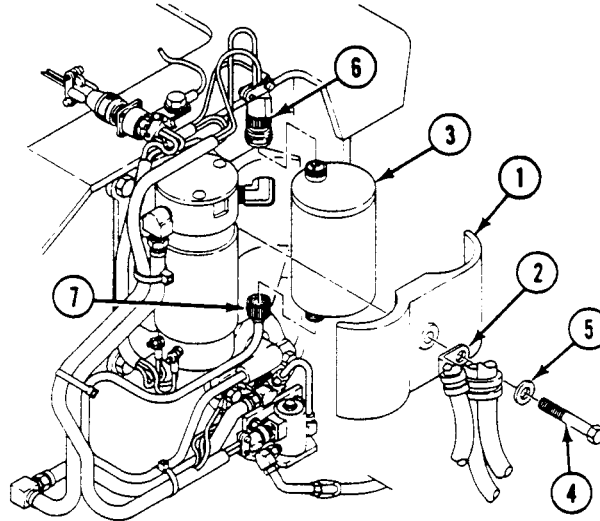
**FOLLOW-THROUGH STEPS**

1. Install power plant rear access panels and support (see your -10).

END OF TASK

REPLACE AIR BOX HEATER LOWER FUEL LINE

0206 00

THIS WORK PACKAGE COVERS:

Removal (page 0206 00-2).
Installation (page 0206 00-3).

INITIAL SETUP:

Maintenance Level

Unit

References

See your -10

Tools and Special Tools

General Mechanic's Tool Kit (WP 0926 00, Item 65)

Equipment Condition

Materials/Parts

Lockwasher

Engine stopped (see your -10)

Personnel Required

Unit Mechanic

Carrier blocked (see your -10)

Power plant removed (WP 0156 00)

REMOVAL

NOTE

Coolant pump pulley bracket is not shown.

1. Remove hose (1) from elbow (2).
2. Remove screw (3), lockwasher (4), washer (5) and clamp (6) from coolant pump. Discard lockwasher.
3. Remove hose (1) from elbow (7).

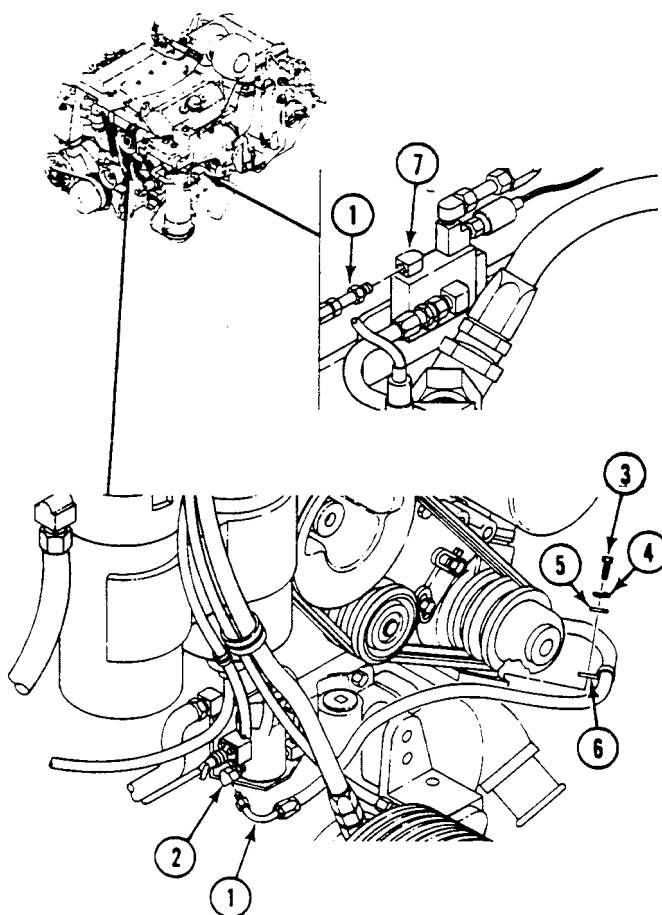

INSTALLATION

1. Install hose (1) on elbow (7).
2. Install screw (3), new lockwasher (4), washer (5) and clamp (6) on coolant pump.
3. Install hose (1) on elbow (2).

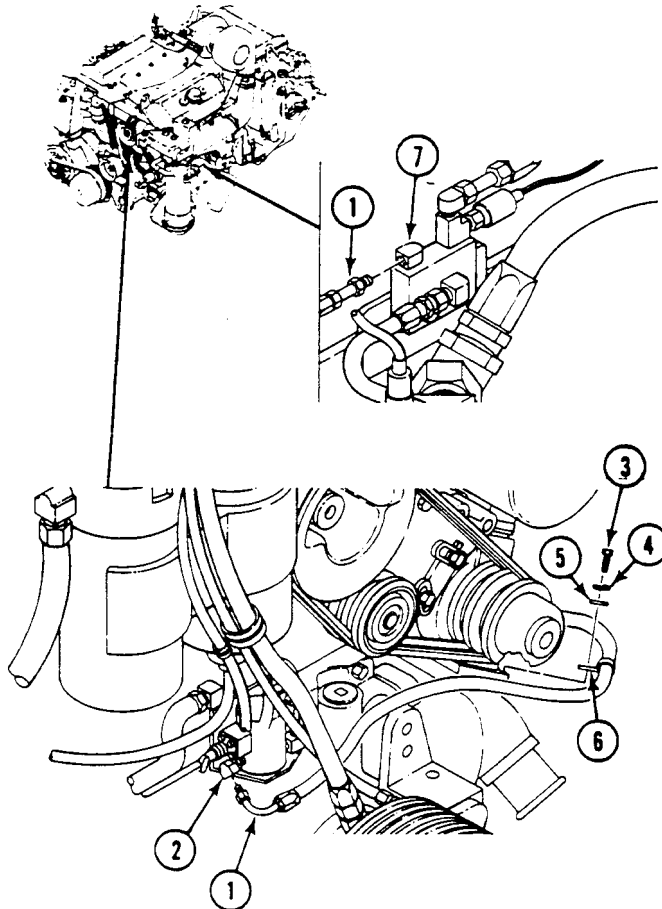
**FOLLOW-THROUGH STEPS**

1. Install power plant (WP 0156 00).

END OF TASK

REPLACE AIR HEATER IGNITER

0207 00

THIS WORK PACKAGE COVERS:

Removal (page 0207 00-1).
 Installation (page 0207 00-2).

INITIAL SETUP:

Maintenance Level

Unit

References

See your -10

Tools and Special Tools

General Mechanic's Tool Kit (WP 0926 00, Item 65)
 Socket wrench set (WP 0926 00, Item 72)
 Torque wrench (WP 0926 00, Item 81)

Equipment Condition

Engine stopped (see your -10)
 Carrier blocked (see your -10)
 Power plant upper rear access panel removed (see your -10)

Personnel Required

Unit Mechanic

REMOVAL

1. Remove harness boot end (1) from air heater electrode (2).
2. Remove electrode (2) from air box heater assembly (3). Use torque wrench with 5/8 inch deep well socket.

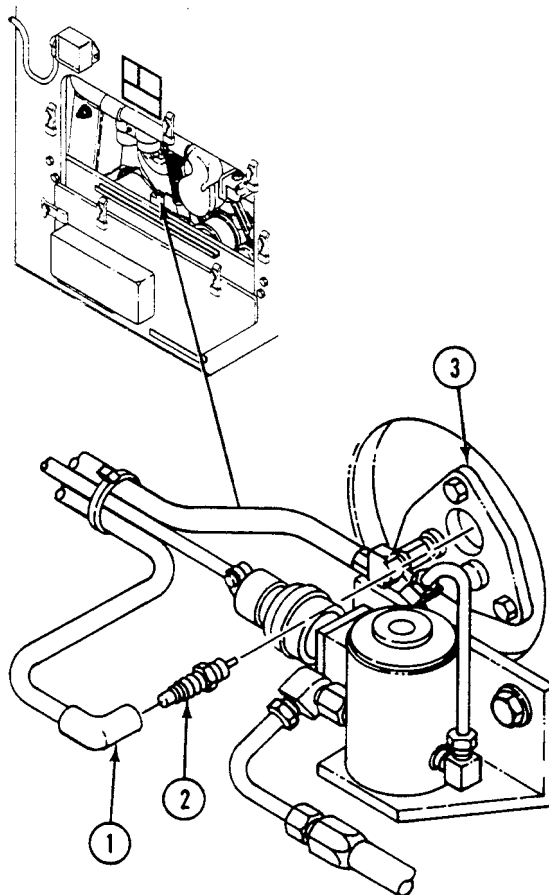

INSTALLATION

1. Thread new electrode (2) into heater box assembly (3). TIGHTEN ELECTRODE TO 180 LB-IN (20 N·m) TORQUE. Use torque wrench with 5/8 inch deep well socket.
2. Install harness boot end (1) on electrode (2) until positive engagement is felt.

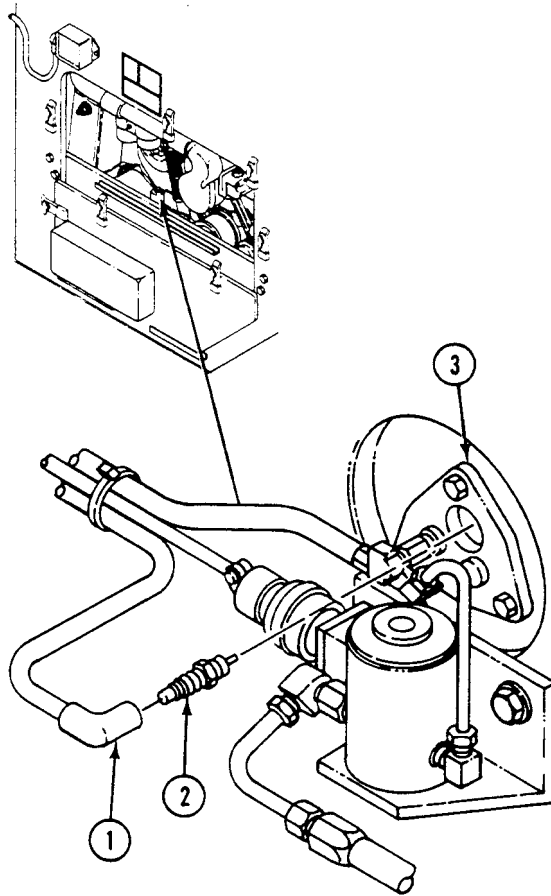
**FOLLOW-THROUGH STEPS**

1. Install power plant upper rear access panel (see your -10).

END OF TASK

REPLACE AIR BOX IGNITION COIL

0208 00

THIS WORK PACKAGE COVERS:

Removal (page 0208 00-1).
 Installation (page 0208 00-3).

INITIAL SETUP:

Maintenance Level

Unit

Equipment Condition

Engine stopped (see your -10)
 Carrier blocked (see your -10)
 Power plant upper rear access panel
 removed (see your -10)

Tools and Special Tools

General Mechanic's Tool Kit (WP 0926 00, Item 65)

Personnel Required

Unit Mechanic

References

See your -10

REMOVAL

1. Loosen screw (1). Remove air box ignition coil (2) and pad (3) from bracket (4).
2. Disconnect lead (5) from air box ignition coil (2).

3. Disconnect igniter lead (6) from air box ignition coil (2). Inspect pad (3). Replace if necessary.

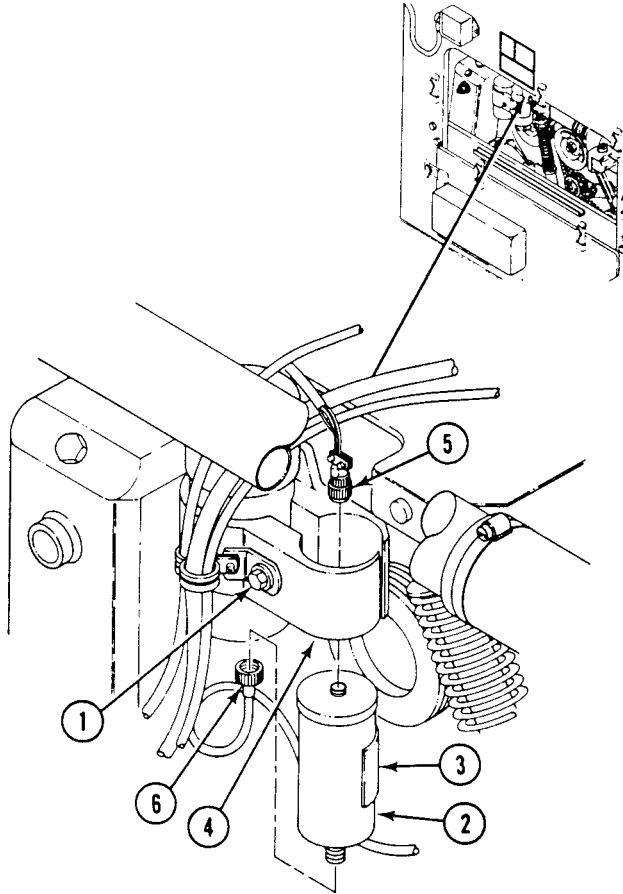

INSTALLATION

1. Connect igniter lead (6) to air box ignition coil (2).
2. Connect lead (5) to air box ignition coil (2).
3. Install air box ignition coil (2) and pad (3) on bracket (4). Tighten screw (1).

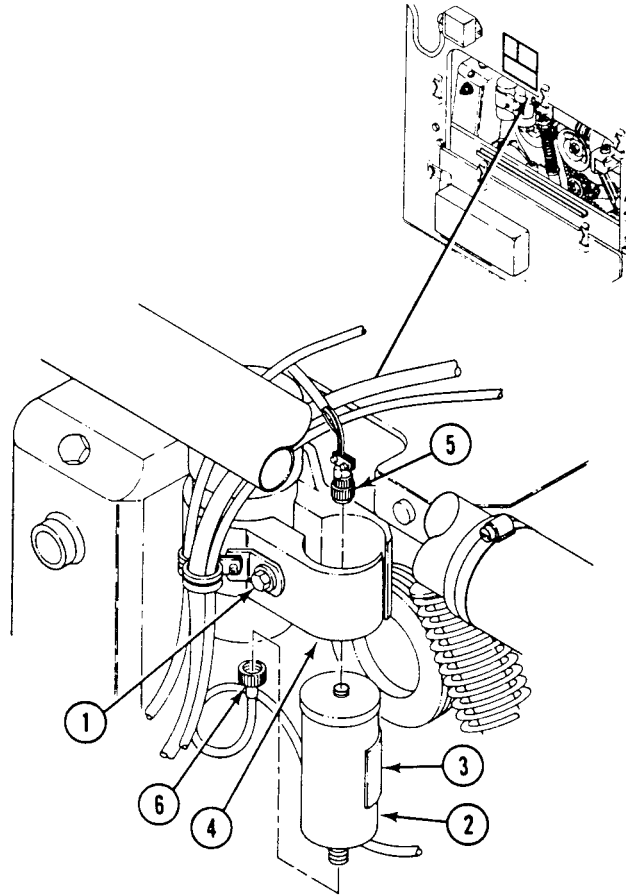
**FOLLOW-THROUGH STEPS**

1. Install power plant upper rear access panel (see your -10).

END OF TASK

REPLACE GLOW PLUG HARNESS AND GLOW PLUGS

0209 00

THIS WORK PACKAGE COVERS:

Removal (page 0209 00-1).
 Installation (page 0209 00-3).

INITIAL SETUP:

Maintenance Level

Unit

Equipment Condition

Engine stopped (see your -10)
 Carrier blocked (see your -10)
 Rear power plant access panel removed (see your -10)
 Battery ground strap disconnected (WP 0337 00),
 (WP 0338 00), or (WP 0339 00)

Tools and Special Tools

General Mechanic's Tool Kit (WP 0926 00, Item 65)
 Torque wrench (WP 0926 00, Item 81)

Personnel Required

Unit Mechanic

References

See your -10

REMOVAL

1. Remove two bolts (1) and nuts (2) securing two clips (3) on glow plug harness (4) to two brackets (5) on left cylinder head (6).
2. Disconnect three plug ends (7) of glow plug harness (4) from glow plugs (8).
3. Remove three glow plugs (8) from left cylinder head (6).
4. Repeat Steps 1 - 3 for opposite side.
5. Disconnect and remove glow plug harness (4) from right side (9) of controller (10).

6. If necessary, remove four clips (3) from glow plug harness (4).

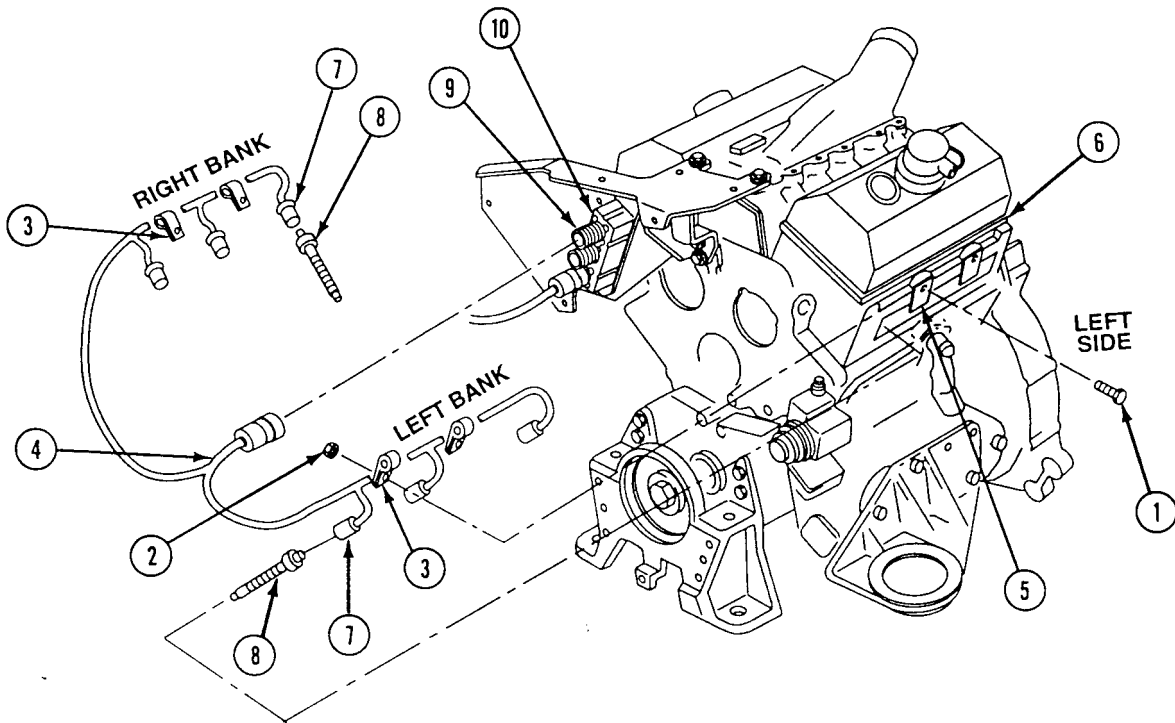

INSTALLATION

1. If removed, install two clips (1) on each side of glow plug harness (2).
2. Connect glow plug harness (2) to right side (3) of glow plug controller (4).
3. Install three glow plugs (5) in left cylinder head (6). TIGHTEN GLOW PLUGS TO 132-156 LB-IN (15-18 N·m) TORQUE.

CAUTION

Glow plug harness leads are identified with location as to right or left bank. Correct installation of wires is necessary for proper diagnostics to aid in locating a failed glow plug.

4. Connect three plug ends (7) of glow plug harness (2) to glow plugs (5) in left cylinder head (6).
5. Secure glow plug harness (2) to two brackets (8) on left side cylinder (6) with two clips (1), bolts (9), and nuts (10). TORQUE BOLTS TO 360-420 LB-IN (41-47 N·m).
6. Repeat Steps 2 - 5 for opposite side.

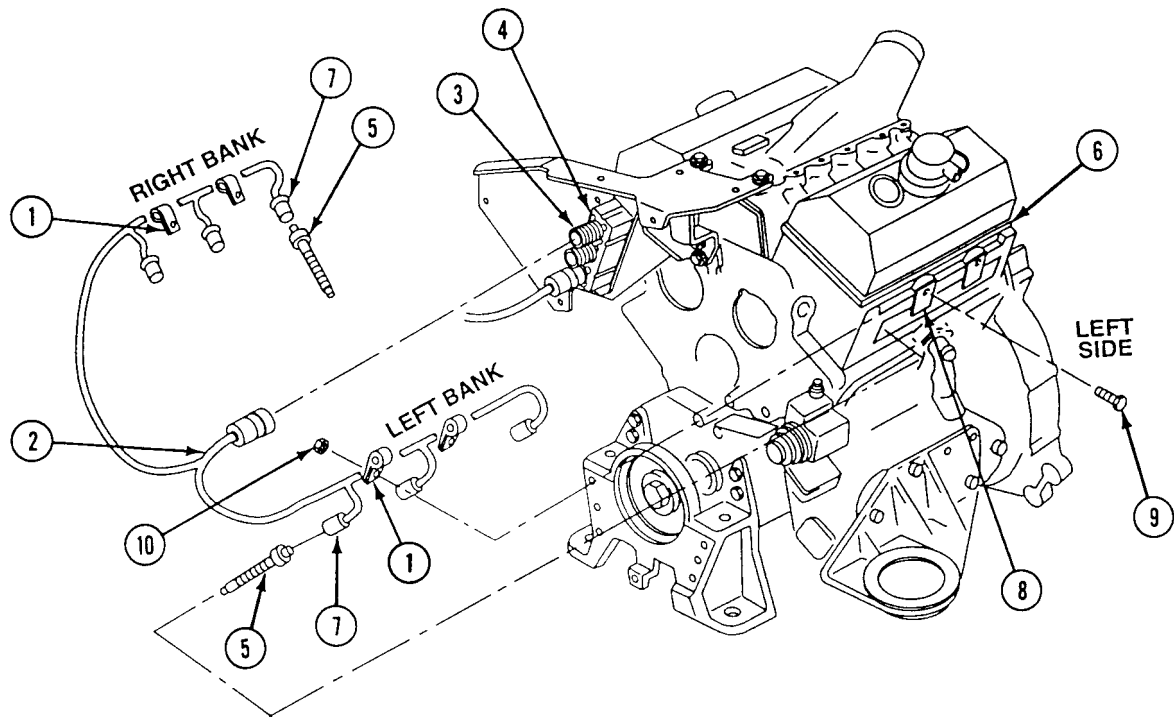
**FOLLOW-THROUGH STEPS**

1. Connect battery ground strap (WP 0337 00), (WP 0338 00), or (WP 0339 00).
2. Install rear power plant access panel (see your -10).

END OF TASK

REPLACE GLOW PLUG CONTROLLER

0210 00

THIS WORK PACKAGE COVERS:

Removal (page 0210 00-1).
 Installation (page 0210 00-3).

INITIAL SETUP:

Maintenance Level

Unit

References

See your -10

Tools and Special Tools

General Mechanic's Tool Kit (WP 0926 00, Item 65)
 Torque wrench (WP 0926 00, Item 83)

Equipment Condition

Engine stopped (see your -10)
 Carrier blocked (see your -10)
 Rear power plant access panel removed (see your -10)
 Battery ground strap disconnected (WP 0337 00),
 (WP 0338 00), or (WP 0339 00)

Materials/Parts

Lockwasher (2)

Personnel Required

Unit Mechanic

REMOVAL

1. Disconnect and remove glow plug power harness (1) from left side (2) of glow plug controller (3).
2. Disconnect and remove glow plug harness (4) from right side (5) of glow controller (3).

REPLACE GLOW PLUG CONTROLLER — Continued

0210 00

3. Remove two bolts (6), lockwashers (7), nuts (8), four washers (9), and glow plug controller (3) from mounting bracket (10) in front of engine. Discard lockwashers.

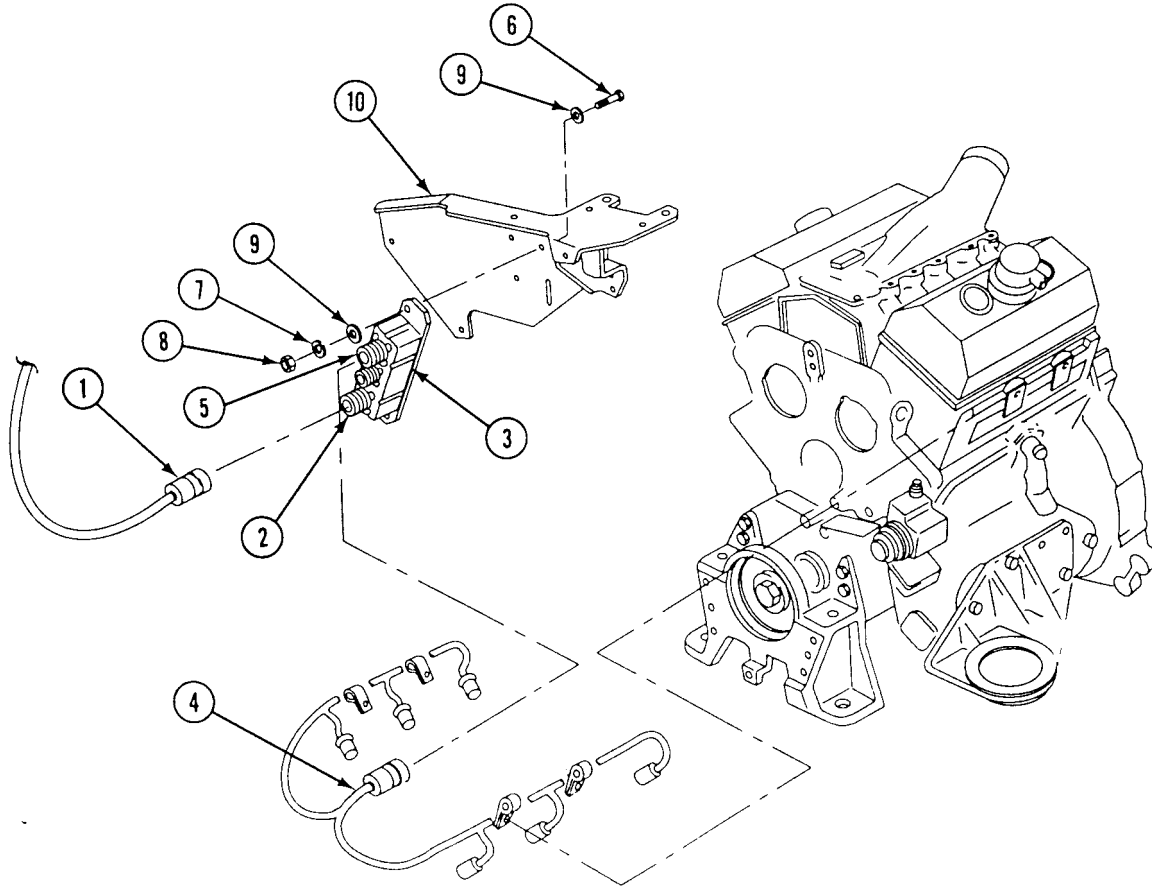

INSTALLATION

1. Install glow plug controller (1), two bolts (2), new lockwashers (3), nuts (4), and four washers (5) on mounting bracket (6). **TIGHTEN BOLTS TO 156-204 LB-IN (18-23 N·m) TORQUE.**
2. Connect glow plug harness (7) to right side (8) of glow plug controller (1).
3. Connect glow plug power harness (9) to left side (10) of glow plug controller (1).

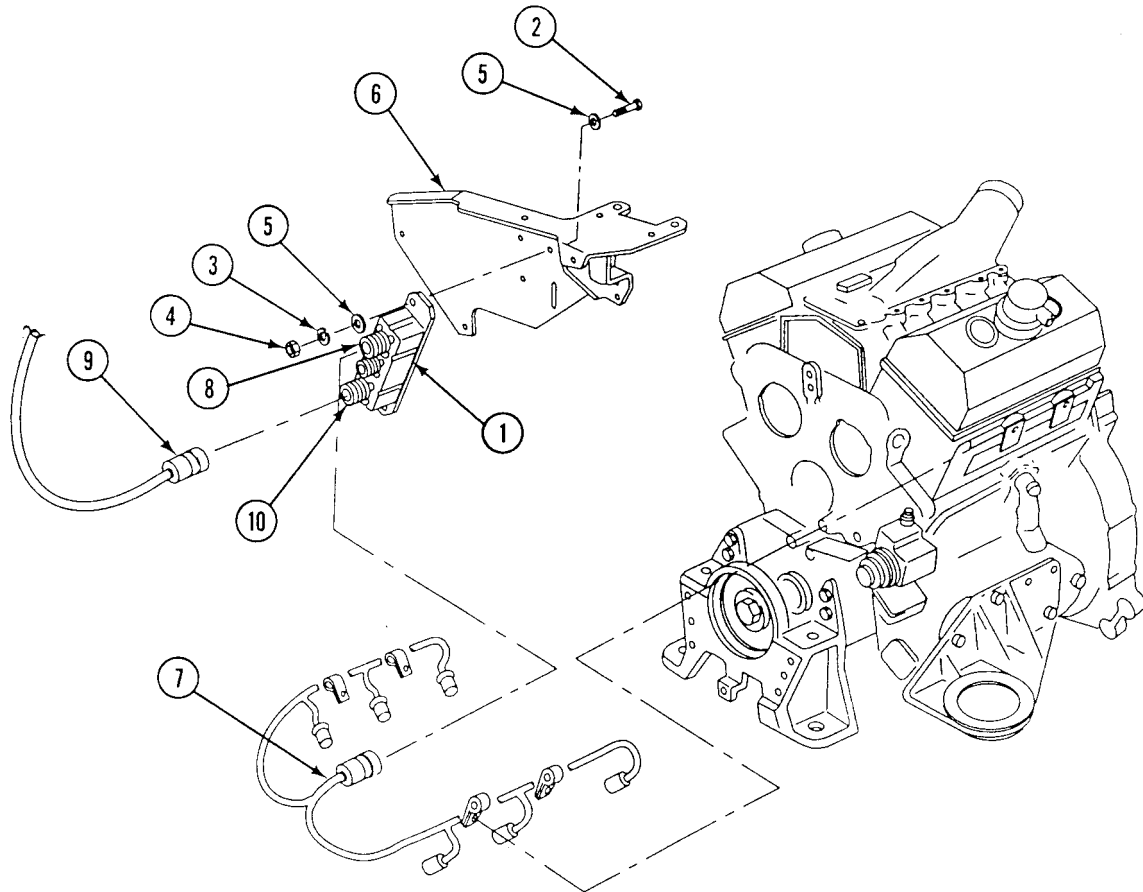
**FOLLOW-THROUGH STEPS**

1. Connect battery ground strap (WP 0337 00), (WP 0338 00), or (WP 0339 00).
2. Install power plant access panel (see your -10).

END OF TASK

REPLACE GLOW PLUG POWER HARNESS

0211 00

THIS WORK PACKAGE COVERS:

Removal (page 0211 00-1).
 Installation (page 0211 00-2).

INITIAL SETUP:

Maintenance Level

Unit

References

See your -10

Tools and Special Tools

General Mechanic's Tool Kit (WP 0926 00, Item 65)

Equipment Condition

Engine stopped (see your -10)
 Carrier blocked (see your -10)
 Driver's power plant access panel removed (see your -10)
 Rear power plant access panel removed (see your -10)
 Battery ground strap disconnected (WP 0337 00), (WP 0338 00), or (WP 0339 00)

Materials/Parts

Lockwasher (3)
 Tie straps (as required)

Personnel Required

Unit Mechanic

REMOVAL

1. Remove nut (1), lockwasher (2), and red double lead (3) from battery terminal (4) on solenoid (5). Do not remove other leads. Reinstall nut on battery terminal. Discard lockwasher.
2. Remove nut (6), lockwasher (7), and orange switch lead (8), from switch terminal (9) on solenoid (5). Do not remove other leads. Reinstall nut on switch terminal. Discard lockwasher.
3. Remove nut (10), lockwasher (11), and blue ground lead (12) from ground terminal (13) on solenoid (5). Do not remove other leads. Reinstall nut on ground terminal. Discard lockwasher.

REPLACE GLOW PLUG POWER HARNESS — Continued**0211 00**

4. Disconnect and remove glow plug power harness (14) from left side (15) of glow plug controller (16).
5. Remove clamp (17), two tie straps (18), and glow plug power harness (14) from engine. Discard tie straps.

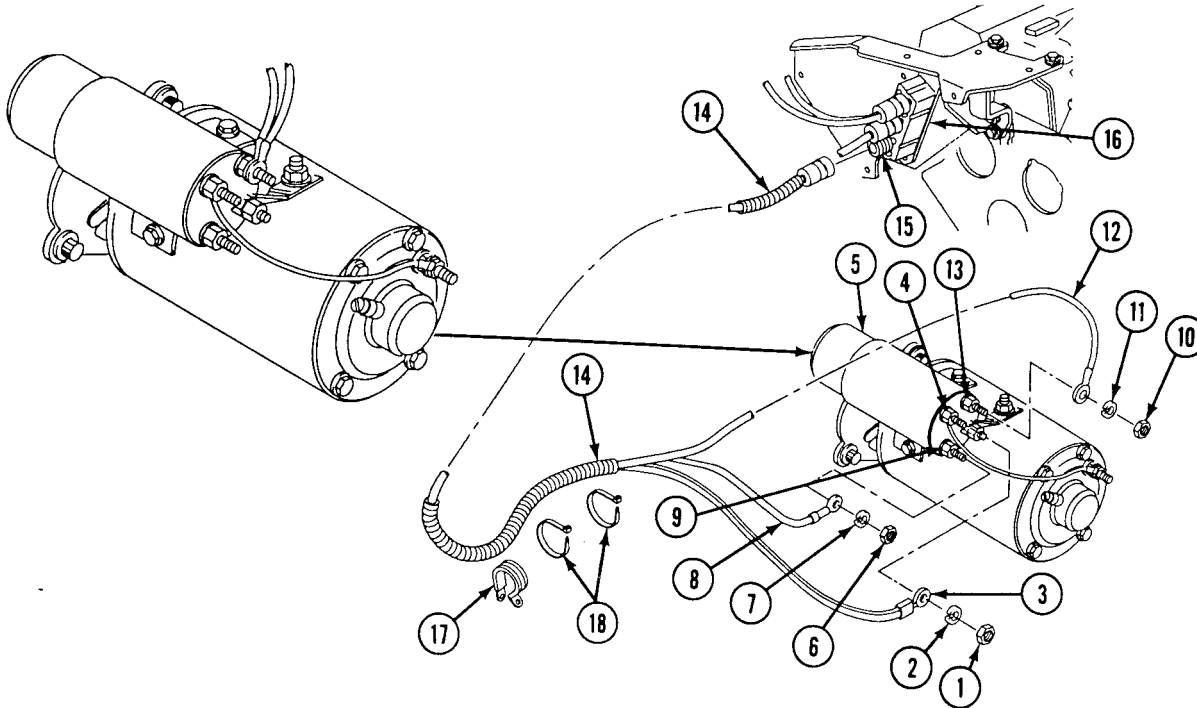
**INSTALLATION**

1. Install glow plug power harness (1), two tie straps (2), and clamp (3) on engine.

REPLACE GLOW PLUG POWER HARNESS — Continued

0211 00

2. Connect glow plug power harness (1) on left side (4) of glow plug controller (5).
3. Remove nut (6) from ground terminal (7). Install blue ground lead (8), new lockwasher (9), and nut on ground terminal.
4. Remove nut (10) from switch terminal (11). Install orange switch lead (12), new lockwasher (13), and nut on switch terminal.
5. Remove nut (14) from battery terminal (15). Install red double lead (16), new lockwasher (17), and nut on battery terminal.

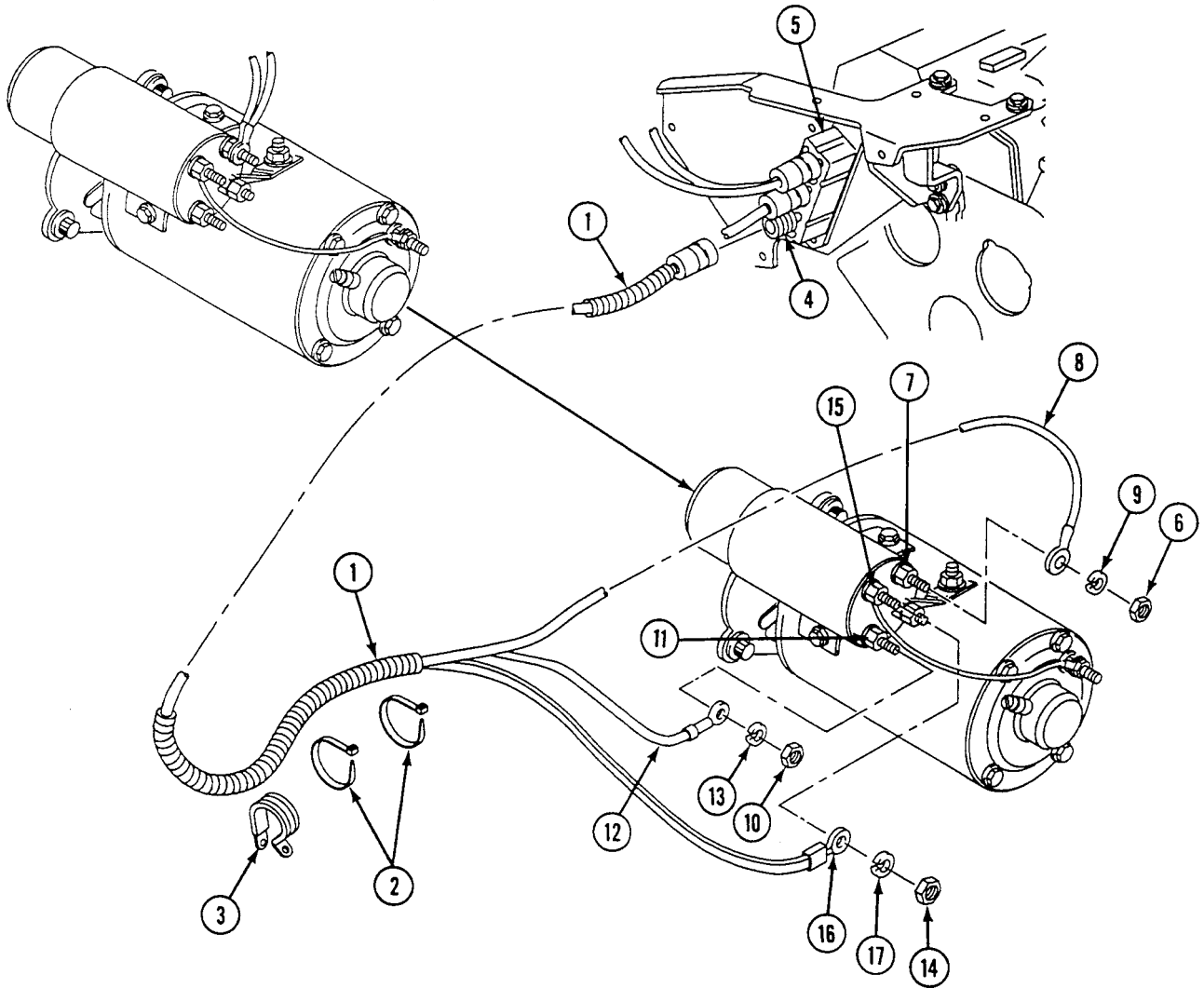

FOLLOW-THROUGH STEPS

1. Connect battery ground strap (WP 0337 00), (WP 0338 00), or (WP 0339 00).
2. Install power plant access panel (see your -10).
3. Install driver's power plant access panel (see your -10).

END OF TASK

REPLACE GLOW PLUG CONTROLLER MOUNTING BRACKET

0212 00

THIS WORK PACKAGE COVERS:

Removal (page 0212 00-1).
 Installation (page 0212 00-2).

INITIAL SETUP:

Maintenance Level

Unit

References

See your -10

Tools and Special Tools

General Mechanic's Tool Kit (WP 0926 00, Item 65)
 Torque wrench (WP 0926 00, Item 81)
 Torque wrench (WP 0926 00, Item 82)

Equipment Condition

Engine stopped (see your -10)
 Carrier blocked (see your -10)
 Rear power plant access panel removed (see your -10)
 Battery ground strap disconnected (WP 0337 00),
 (WP 0338 00), or (WP 0339 00)

Materials/Parts

Lockwasher (4)
 Lockwasher (2)

Personnel Required

Unit Mechanic

REMOVAL

1. Remove two bolts (1), lockwashers (2), nuts (3), four washers (4), and glow plug controller (5) from mounting bracket (6) on front of engine. Discard lockwashers.
2. Remove two short screws (7), lockwashers (8), and washers (9) from front of mounting bracket (6).
3. Remove two long screws (10), lockwashers (11), washers (12), spacers (13), and mounting bracket (6) from engine. Discard lockwashers.

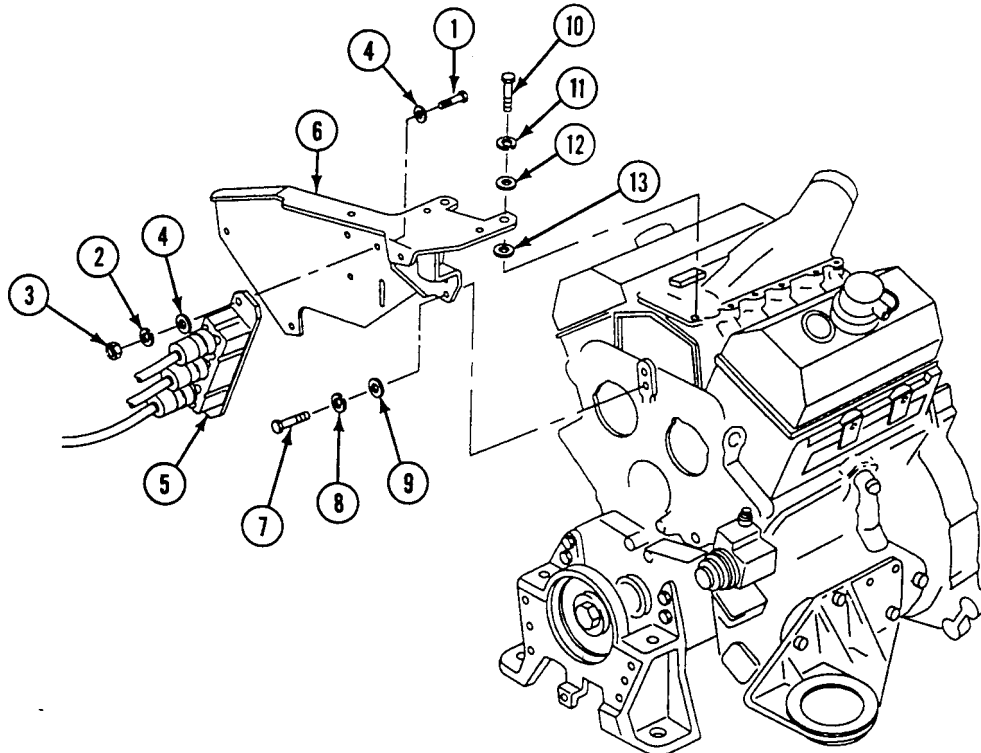

INSTALLATION

1. Install mounting bracket (1), two spacers (2), washers (3), new lockwashers (4), and long screws (5) on front of engine. TIGHTEN SCREWS TO 192-240 LB-IN (22-27 N·m) TORQUE. USE TORQUE WRENCH.
2. Install two washers (6), new lockwashers (7), and short screws (8) into front of mounting bracket (1). TIGHTEN SCREWS TO 46-50 LB-FT (62-68 N·m) TORQUE. USE TORQUE WRENCH.
3. Install glow plug controller (9), four washers (10), two new lockwashers (11), bolts (12), and nuts (13) on mounting bracket (1).

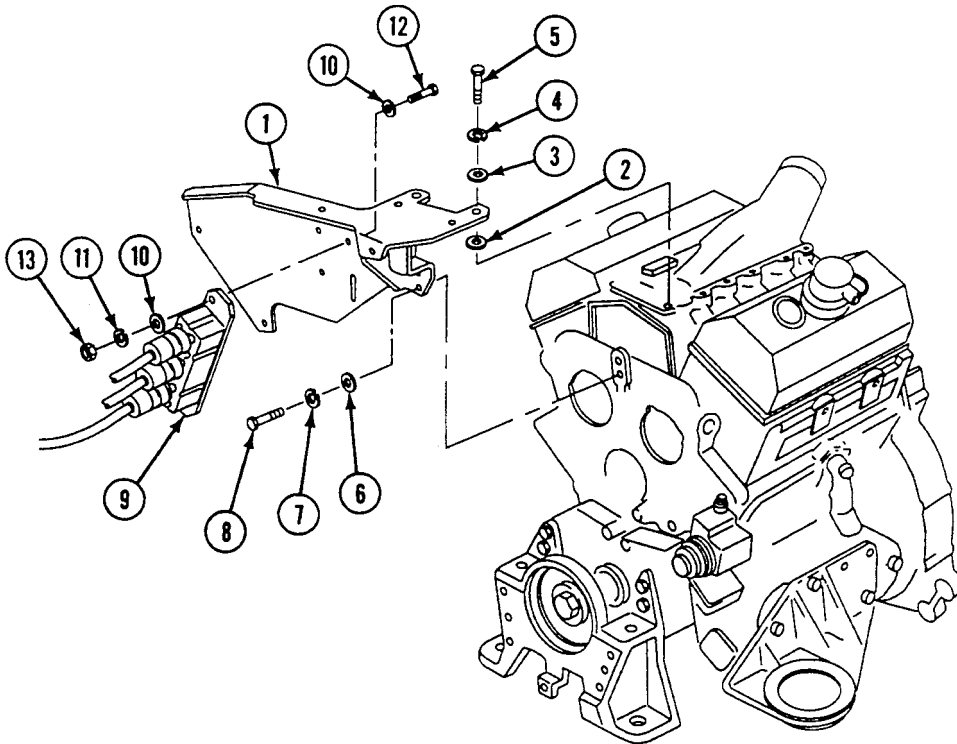
**FOLLOW-THROUGH STEPS**

1. Connect battery ground strap (WP 0337 00), (WP 0338 00), or (WP 0339 00).
2. Install engine access panel (see your -10).

END OF TASK

ADJUST THROTTLE VALVE (TV) MODULATOR

0213 00

THIS WORK PACKAGE COVERS:

Adjustment (page 0213 00-1).
 Field Operational Test (page 0213 00-5).

INITIAL SETUP:

Maintenance Level

Unit

Tools and Special Tools

General Mechanic's Tool Kit (WP 0926 00, Item 65)
 Pressure Gauge Kit (WP 0926 00, Item 35)

Materials/Parts

Sealing compound (WP 0928 00, Item 56)

Personnel Required

Unit Mechanic

References

See your -10

Equipment Condition

Engine warm
 Parking brake set (see your -10)
 Engine stopped (see your -10)
 Carrier blocked (see your -10)
 Trim vane lowered (see your -10)
 Power plant front access door opened (see your -10)
 Driver's power plant access panel
 removed (see your -10)

ADJUSTMENT

1. Check to make sure throttle valve modulator lever (1) is in idle position.
2. Adjust two hex nuts (2) so cable modulator bracket (3) is located near mid-range of threaded portion of cable housing (4). Tighten nuts.

NOTE

Steps 3 - 15 are an initial adjustment prior to FIELD OPERATIONAL TEST.

3. Check to make sure anchor (5) is 4-9/16 to 4-7/16 inches (11.3 to 11.5 cm) from bracket (3). If adjustment is needed, loosen hex nut (6) and reposition lever (1) by adjusting two nuts (7)(8) so anchor (5) is located near mid-range of threaded portion of cable end (9). Tighten nuts (6)(7)(8).

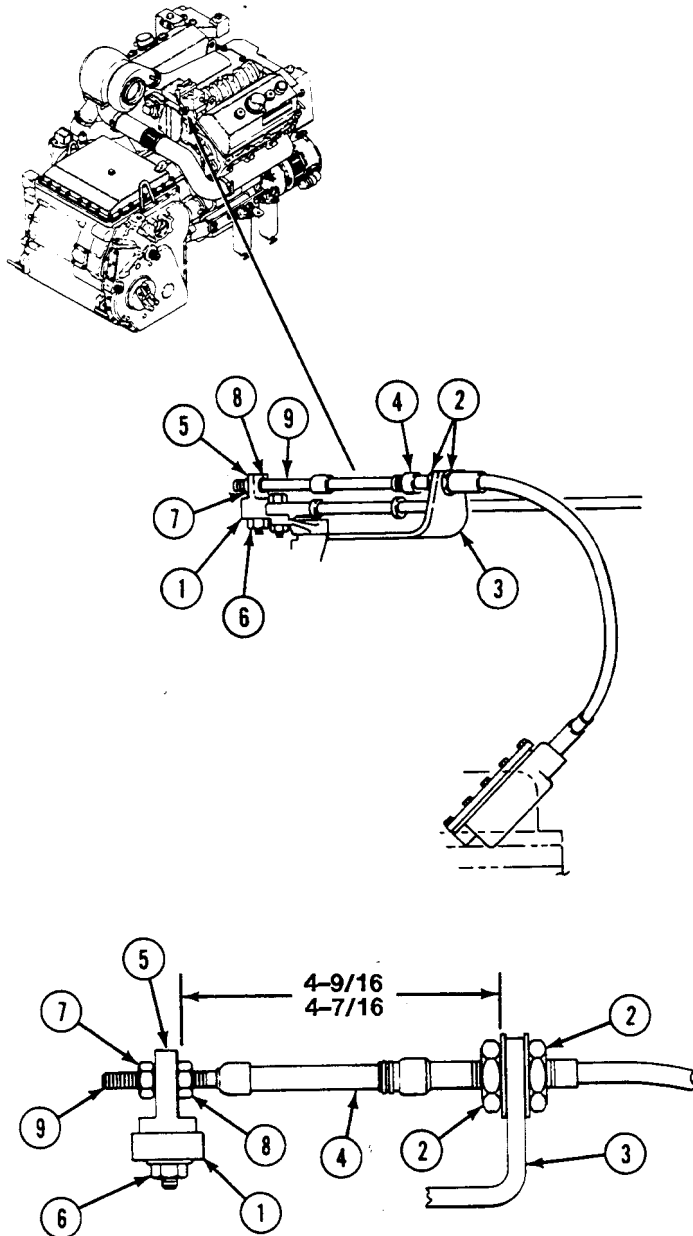

4. Open pressure gauge kit (1), and remove 0 to 160 psi (0 to 7607 kPa) pressure gauge (2), hose (3), and quick-disconnect fitting (4).

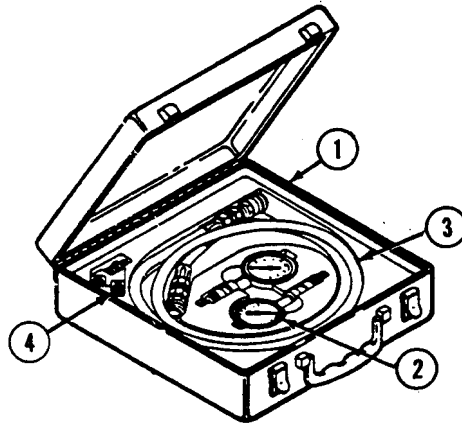

5. Remove pipe plug (5) from elbow (6) in throttle valve test port on transmission. Retain pipe plug.
6. Install quick-disconnect fitting (4) on elbow (6).
7. Install hose (3) on quick-disconnect fitting (4).
8. Install pressure gauge (2) on hose (3).

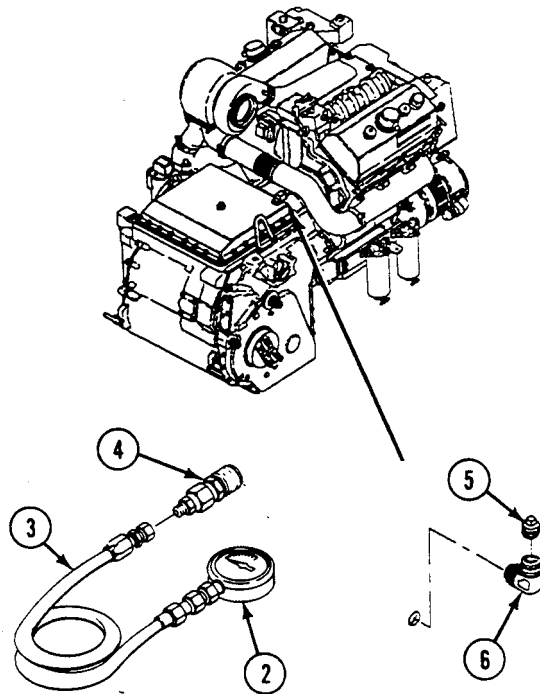

WARNING

Make sure parking brake is set before you start engine. Carrier could lurch and injure you.

9. Start engine and let idle with shift lever in the STEER LOCK (SL) position for 10 minutes or until engine reaches operating temperature (see your -10).
10. Depress accelerator fully to increase engine speed to full governed RPM. Pressure gauge should read from 94 to 98 psi (648 to 676 kPa).
11. If the pressure reading is below 94 psi (648 kPa), COURSE adjust throttle valve modulator linkage first by turning two adjusting nuts (7), one turn at a time, to the left, and then FINE adjust throttle valve modulator linkage by turning two adjusting nuts (8), one turn at a time, to the right.

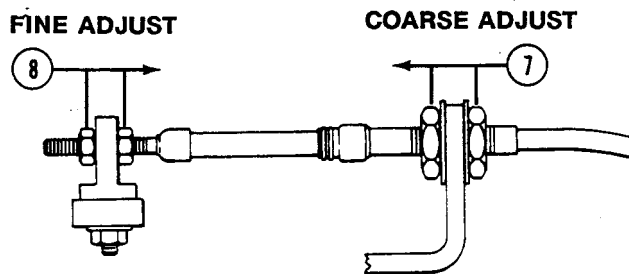

12. If the pressure gauge reading is above 98 psi (676 kPa), COURSE adjust throttle valve modulator linkage first by turning two adjusting nuts (7), one turn at a time to the right, and then FINE adjust throttle valve modulator linkage by turning two adjusting nuts (8), one turn at a time, to the left.

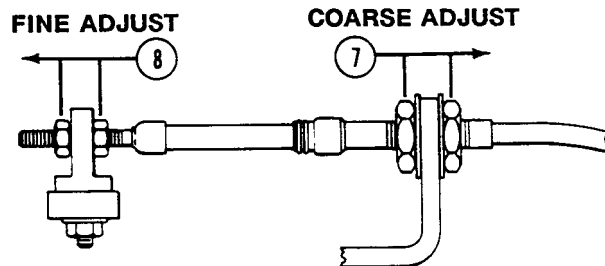

13. Stop engine (see your -10).

14. Remove quick-disconnect fitting (1) from elbow (2), hose (3) from quick-disconnect fitting (1), and pressure gauge (4) from hose (3). Stow in kit.
15. Apply a light coat of sealing compound to male threads of pipe plug (5), and install pipe plug in elbow (2).

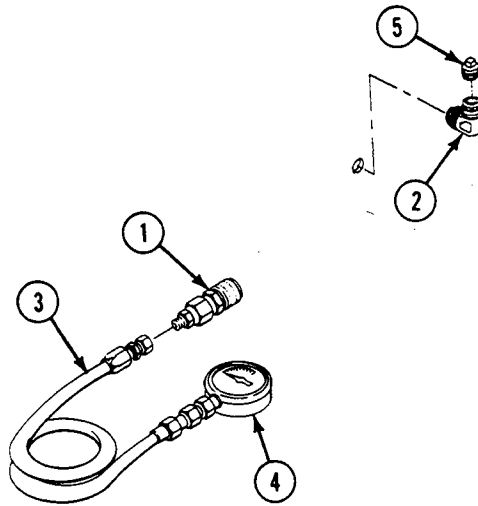

END OF TASK

TESTING

FIELD OPERATIONAL TEST

NOTE

Use judgment in evaluating speedometer readings by considering the variables that may effect the speedometer.

A cable driven speedometer can be affected by temperature and moisture, amount of bend in the cable, age, number of miles on the carrier, amount of lubricant used, and manufacturing tolerance error of ± 5 percent. All of these possibilities can result in speedometer lag (a reading slower than actual speed during acceleration).

The angle in which the driver looks at the speedometer can cause a 1 to 2 mile per hour error/difference. The height of an individual, seat height, or angle could account for inconsistency in speedometer readings. The higher the driver's vantage point, the more he tends to read below the actual speed.

If the transmission shifts smoothly and reaches top speed (30 to 39 mph (48 to 63 kph)) without lagging during wide open throttle tests, consider the adjustment complete even if the speedometer reading is somewhat outside the limits shown in the following steps.

1. Operate the carrier (see your -10). Drive the carrier on straight, level terrain with shift lever in the 1-4 position. Accelerate carrier with accelerator pedal fully depressed (wide open throttle). Verify that the following transmission shifts occur at the speeds shown:

Upshift 1 to 2	7 mph (11 km/h) min
Upshift 2 to 3	18 mph (29 km/h) max

NOTE

If shifts are within ranges, adjustment is complete. If not, do Step 2 and Step 3.

2. If the upshift 1 to 2 is below 7 mph (11 km/h), do ADJUST Step 11 again.
3. If upshift 2 to 3 is above 18 mph (29 km/h), do ADJUST Step 12 again.

NOTE

Do Step 4 only if the minimum/maximum shift points in Step 1 have not been obtained.

4. If more adjustment is needed, reposition throttle valve modulator lever (1) as follows:
 - a. Loosen hex nuts (2)(3)(4).
 - b. Adjust lever (1) away from modulator bracket (5) if upshift 1 to 2 is below 7 mph (11 km/h).
 - c. Adjust lever (1) toward modulator bracket (5) if upshift 2 to 3 is above 18 mph (29 km/h).
 - d. Tighten hex nuts (2)(3)(4).
5. Repeat Steps 1 - 4 until shift ranges are met.

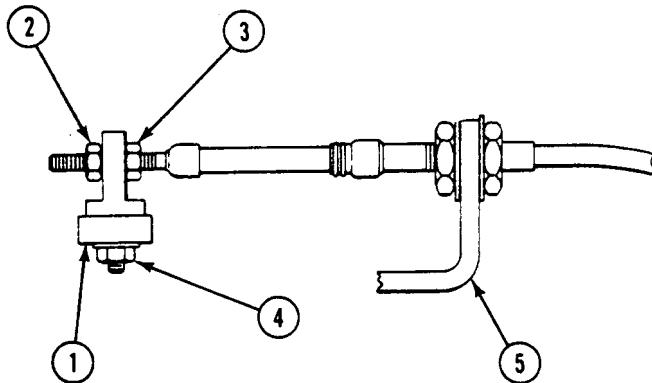
**FOLLOW-THROUGH STEPS**

1. Install driver's power plant access panel (see your -10).
2. Close power plant front access door (see your -10).
3. Raise trim vane (see your -10).

END OF TASK

ADJUST ACCELERATOR LINKAGE

0214 00

THIS WORK PACKAGE COVERS:

Adjustment (page 0214 00-1).

INITIAL SETUP:

Maintenance Level

Unit

References

See your -10

Tools and Special Tools

General Mechanic's Tool Kit (WP 0926 00, Item 65)

Equipment Condition

Engine stopped (see your -10)

Carrier blocked (see your -10)

Trim vane lowered (see your -10)

Power plant front access door opened (see your -10)

Driver's power plant access panel

removed (see your -10)

Power plant front access cover removed (WP 0449 00)

Materials/Parts

Locknut

Locknut

Personnel Required

Unit Mechanic

Helper (H)

ADJUSTMENT

1. Remove screw (1), locknut (2), washer (3), and governor connecting link (4) from governor throttle arm (5). Discard locknut.

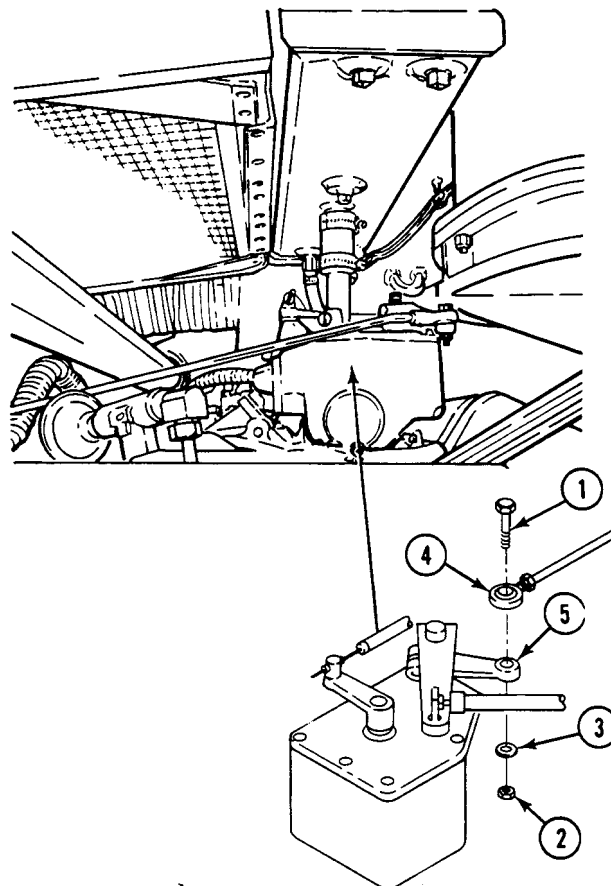

2. Remove screw (6), locknut (7), two washers (8), and throttle drag link (9) from accelerator arm (10). Discard locknut. Have helper assist.

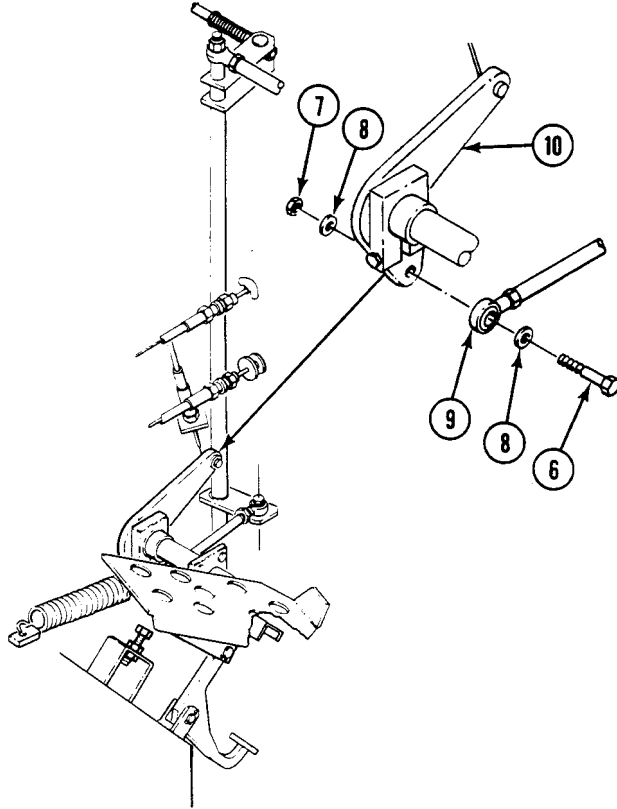

3. Position upper accelerator pedal (1) against heel stop (2). Have helper assist.
4. Loosen jamnut (3) on throttle drag link (4).

NOTE

Turn rod end bearing to the left to lengthen throttle drag link, or to the right to shorten link during adjustment.

5. Turn fuel control shaft (5) to the right until center of connecting pin (6) is 1-1/16 to 1-1/8 inches (27 to 29 mm) from power plant bulkhead. (H) Hold functional shaft in position.

NOTE

Make sure free pin fit is made during adjustment.

6. Install throttle drag link (4), two washers (7), screw (8), and new locknut (9) on accelerator arm (10). Tighten jamnut (3).

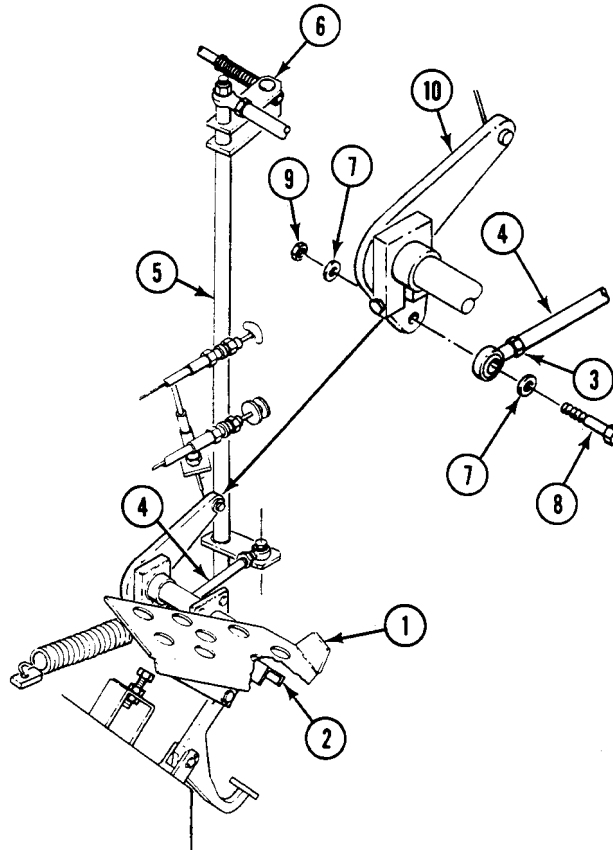

7. Loosen jamnut (11) on governor connecting link (12).
8. Position upper accelerator pedal (1) against heel stop (2). Have helper assist.

NOTE

Make sure governor throttle arm is in idle position.

9. Adjust length of governor connecting link (12) to allow a free pin fit when screw (13) is inserted in bearing (14) and governor throttle arm (15).

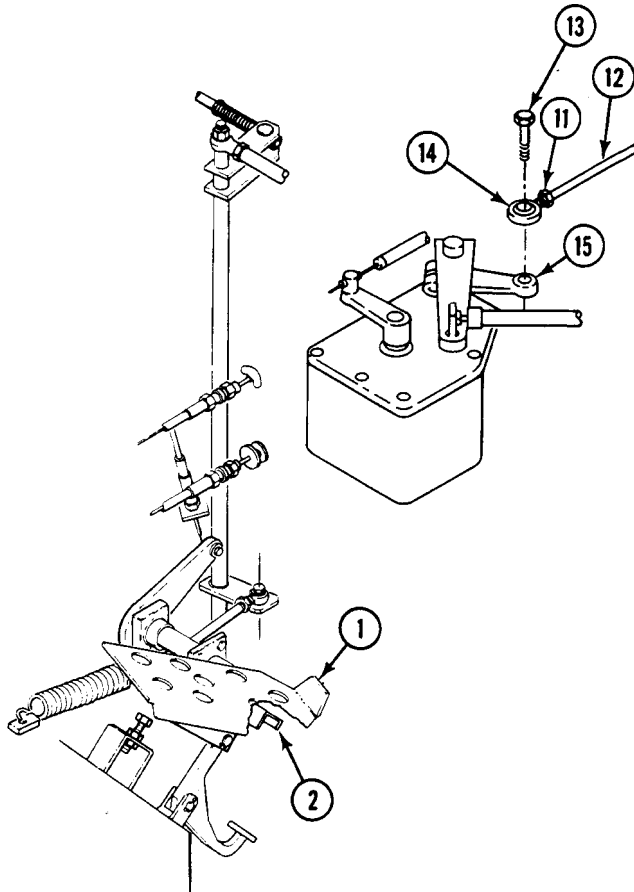

10. Install governor connecting link (1), washer (2), screw (3), and new locknut (4) on governor throttle arm (5). Tighten jamnut (6).

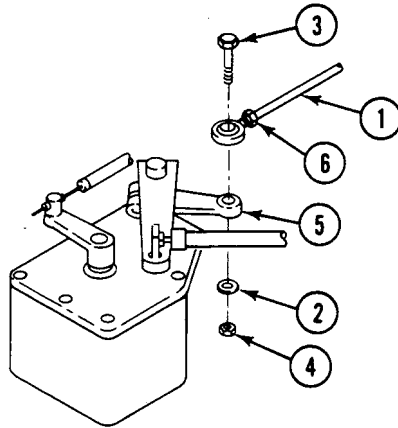

11. Loosen pedal toe stop screw (7) and jamnut (8).
12. Depress accelerator pedal (9) until edge of connecting pin (10) is 1/32 to 1/16 inch (1 to 1.5 mm) away from washer (11). Adjust pedal toe stop screw (7) and tighten jamnut (8). Have helper assist.

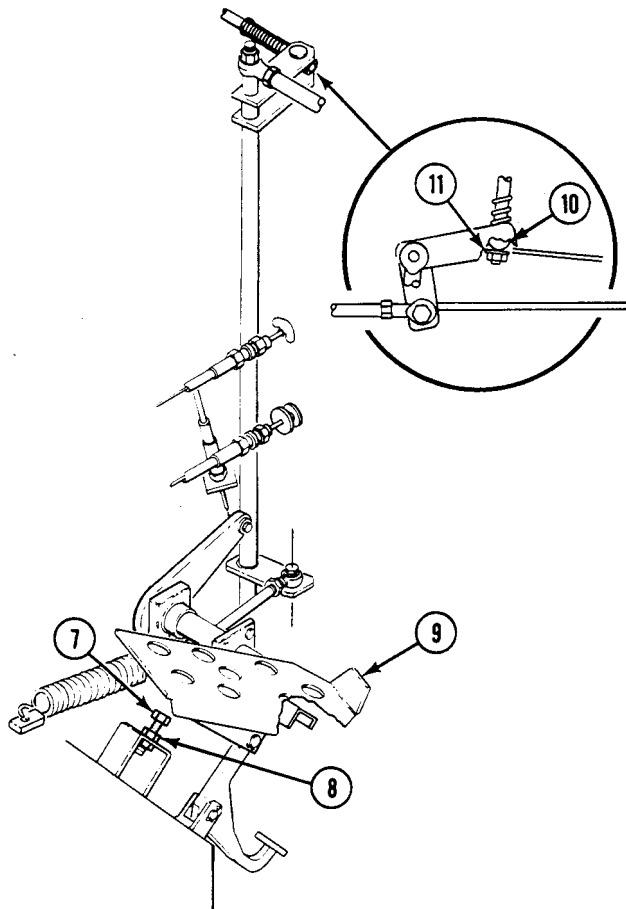

FOLLOW-THROUGH STEPS

1. Install power plant front access cover (WP 0449 00).
2. Install driver's power plant access panel (see your -10).
3. Close power plant front access door (see your -10).
4. Raise trim vane (see your -10).

END OF TASK

REPLACE LOWER ACCELERATOR PEDAL

0215 00

THIS WORK PACKAGE COVERS:

Removal (page 0215 00-1).
 Installation (page 0215 00-3).

INITIAL SETUP:

Maintenance Level

Unit

References

See your -10

Tools and Special Tools

General Mechanic's Tool Kit (WP 0926 00, Item 65)

Equipment Condition

Materials/Parts

Cotter pin

Cotter pin

Engine stopped (see your -10)

Carrier blocked (see your -10)

Personnel Required

Unit Mechanic

Ramp lowered (see your -10)

Driver's seat removed (WP 0551 00)

REMOVAL

1. Remove cotter pin (1) and washer (2) from connecting pin (3) securing lower pedal (4) and connecting link (5) to upper pedal assembly (6).
2. Remove connecting pin (3) from pedal (4) and connecting link (5). Discard cotter pin.
3. Remove cotter pin (7) and washer (8) from connecting pin (9) securing lower pedal (4) to bracket (10).

4. Remove connecting pin (9), and lower pedal (4) from bracket (10). Discard cotter pin.

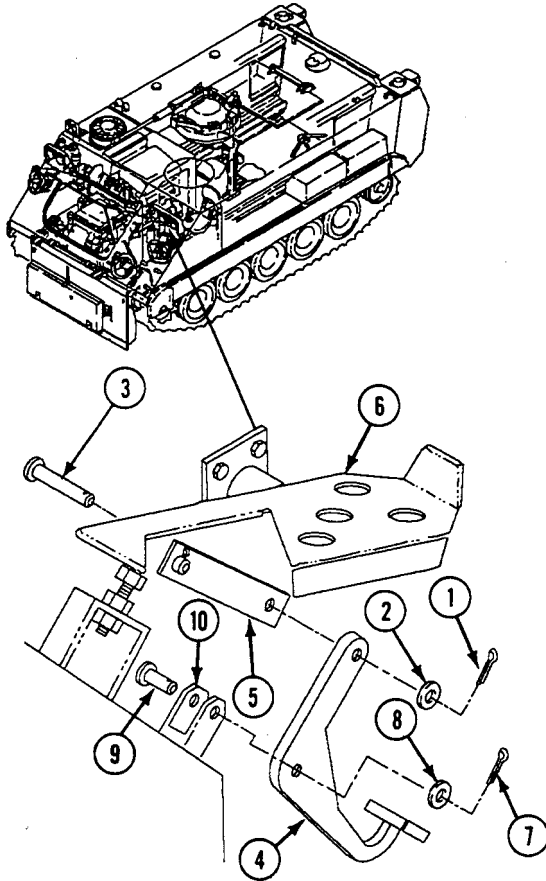

INSTALLATION

1. Place lower pedal (4) on bracket (10). Align holes in bracket and pedal. Install connecting pin (9) through bracket (10) and pedal (4).
2. Install washer (8) on connecting pin (9) and secure with new cotter pin (7).
3. Align holes in connecting link (5) and pedal (4). Install connecting pin (3) through connecting link (5) and pedal (4).
4. Install washer (2) on connecting pin (3) and secure with new cotter pin (1).

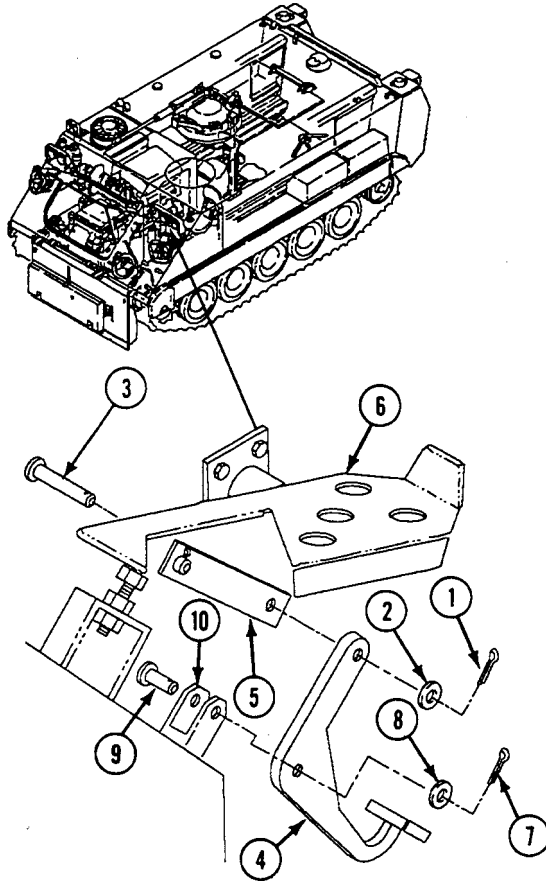
**FOLLOW-THROUGH STEPS**

1. Install driver's seat (WP 0551 00).
2. Start engine (see your -10). Check that accelerator pedal works right.
3. Raise and lock ramp (see your -10).

END OF TASK

REPLACE UPPER ACCELERATOR PEDAL ASSEMBLY

0216 00

THIS WORK PACKAGE COVERS:

- Removal (page 0216 00-1).
- Installation (page 0216 00-3).

INITIAL SETUP:

Maintenance Level

Unit

References

See your -10

Tools and Special Tools

General Mechanic's Tool Kit (WP 0926 00, Item 65)

Equipment Condition

- Engine stopped (see your -10)
- Carrier blocked (see your -10)
- Trim vane lowered (see your -10)
- Power plant front access cover removed (WP 0449 00)
- Power plant front access door opened (see your -10)
- Driver's power plant access panel removed (see your -10)

Materials/Parts

- Cotter pin
- Cotter pin
- Cotter pin
- Locknut

Personnel Required

Unit Mechanic

REMOVAL

1. Remove spring (1) from throttle control arm (2) and bracket (3) on power plant bulkhead.

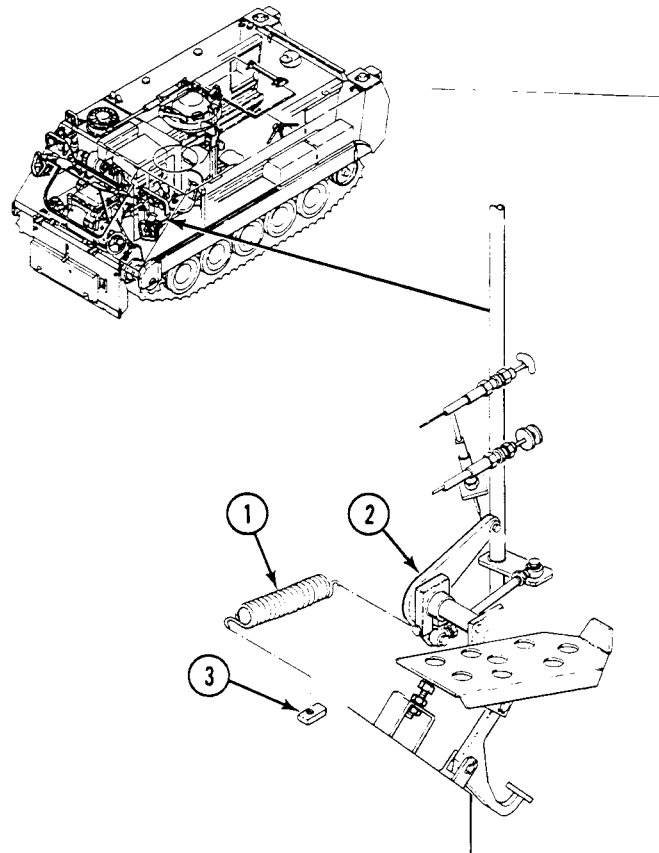

REPLACE UPPER ACCELERATOR PEDAL ASSEMBLY — Continued

0216 00

2. Remove locknut (1), washer (2) and screw (3) securing drag link (4) to fuel control shaft plate (5). Discard locknut.
3. Loosen locknut (6) on throttle control arm (7). Remove throttle control arm (7) with drag link (4) from shaft (8). Remove locknut (6), washer (9) and screw (10) from throttle control arm. Discard locknut. Have helper assist.
4. Remove cotter pin (11), and washer (12) securing hand throttle pin (13) to throttle control arm (7). Remove hand throttle pin (13) with cable (14). Discard cotter pin.
5. Remove locknut (15), two washers (16) and screw (17) securing drag link (4) to throttle control arm (7). Discard locknut.

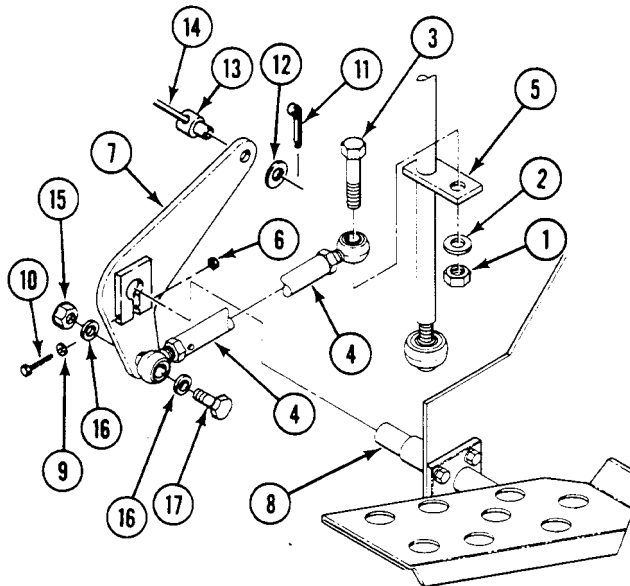

6. Remove cotter pin (18), washer (19), pin (20), and link (21) from lower accelerator pedal (22). Discard cotter pin.
7. Remove four screws (23) and washers (24) securing pedal guide (25) to bulkhead.

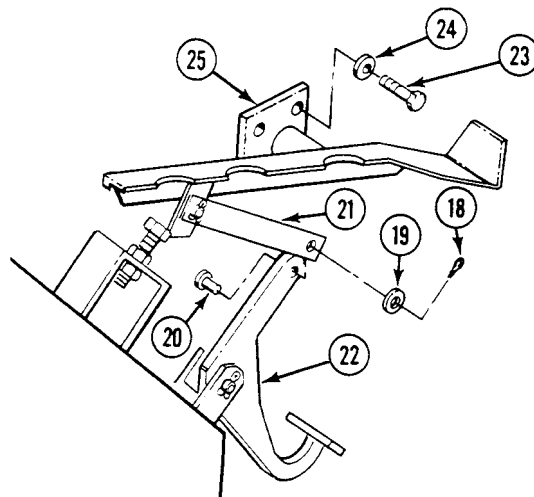

REPLACE UPPER ACCELERATOR PEDAL ASSEMBLY — Continued**0216 00**

8. Remove upper accelerator pedal (26) with pedal guide (25) and link (21) from bulkhead.
9. Remove cotter pin (27), washer (28) and pin (29) securing link (21) to upper accelerator pedal (26). Remove link. Discard cotter pin.
10. Remove woodruff key (30) and pedal guide (25) from shaft (8).

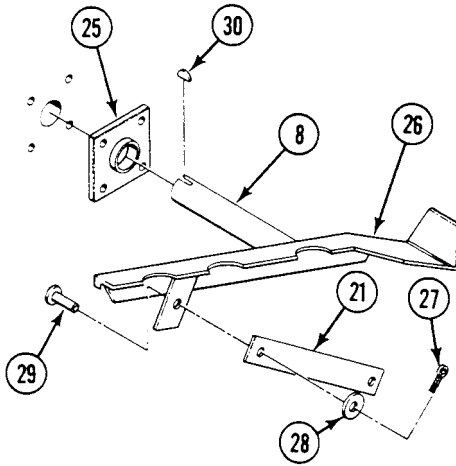
**INSTALLATION**

1. Install link (21) on upper accelerator pedal (26) and secure with pin (29), washer (28) and new cotter pin (27).
2. Install pedal guide (25) and woodruff key (30) on shaft (8).
3. Install upper accelerator pedal (26) with link (21) and pedal guide (25) in driver's right side bulkhead.

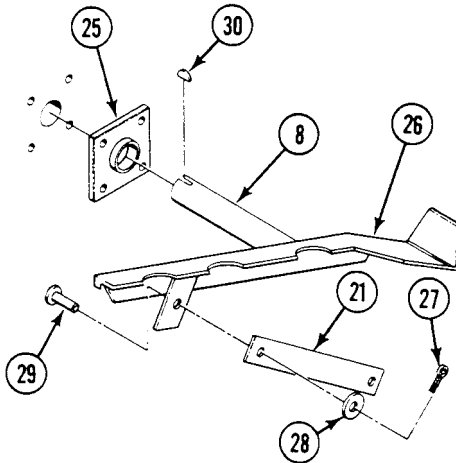

4. Secure pedal guide (1) to bulkhead with four washers (2) and screws (3).
5. Install link (4) on lower accelerator pedal (5) and secure with pin (6), washer (7) and new cotter pin (8).

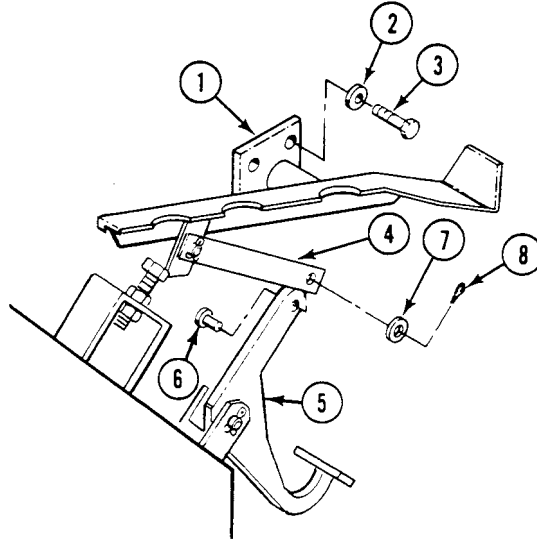

6. Install screw (9), washer (10) and new locknut (11) on new throttle control arm (12). Do not tighten at this time.
7. Install hand throttle pin (13) with cable (14) on throttle control arm (12) and secure with washer (15) and new cotter pin (16).
8. Install drag link (17) on throttle control arm (12) and secure with screw (18), two washers (19) and new locknut (20).
9. Install throttle control arm (12) on shaft (21). Align arm with woodruff key. Hold nut (11) and tighten screw (9).
10. Install drag link (17) on fuel control shaft plate (22) and secure with screw (23), washer (24) and new locknut (25).

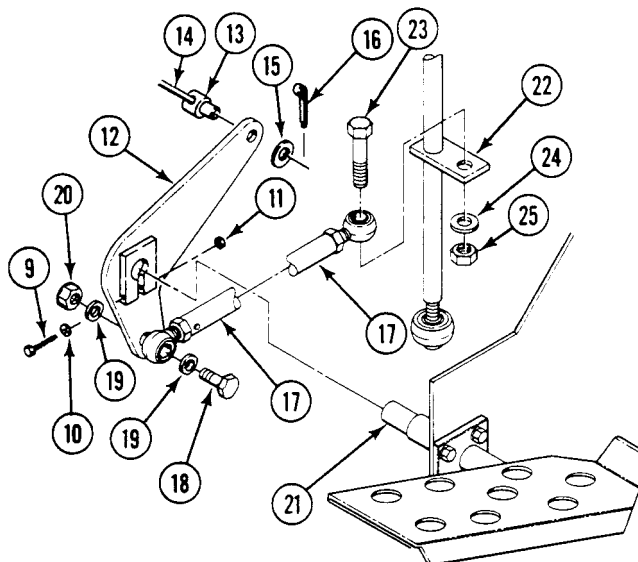

11. Install spring (26) in bracket (27) on power plant bulkhead and throttle control arm (12).

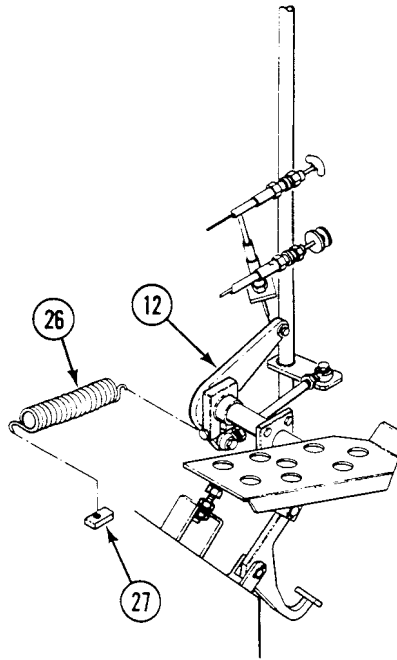
**FOLLOW-THROUGH STEPS**

1. Adjust accelerator linkage (WP 0214 00).
2. Install power plant front access cover (WP 0449 00).
3. Install driver's power plant access panel (see your -10).
4. Close power plant front access door (see your -10).
5. Raise trim vane (see your -10).

END OF TASK

REPLACE FUEL CONTROL SHAFT AND LINKAGE

0217 00

THIS WORK PACKAGE COVERS:

Removal (page 0217 00-1).
 Installation (page 0217 00-4).

INITIAL SETUP:

Maintenance Level

Unit

References

See your -10

Tools and Special Tools

General Mechanic's Tool Kit (WP 0926 00, Item 65)

Equipment Condition

Engine stopped (see your -10)
 Carrier blocked (see your -10)
 Trim vane lowered (see your -10)
 Power plant front access door opened (see your -10).
 Driver's compartment power plant access panel
 removed (see your -10)
 Power plant front access cover removed (WP 0449 00)
 Air intake elbow removed (WP 0173 00)

Materials/Parts

Cotter pin
 Locknut (7)
 Lockwasher (2)

Personnel Required

Unit Mechanic

REMOVAL

1. Remove spring (1) from bulkhead.
2. Remove locknut (2), two washers (3) and screw (4) securing drag link (5) to throttle control arm (6). Discard locknut.
3. Remove locknut (7), washer (8) and screw (9) securing drag link (5) to shaft (10). Remove drag link.

4. Remove locknut (11), washer (12) and screw (13) securing linkage (14) to arm (15).

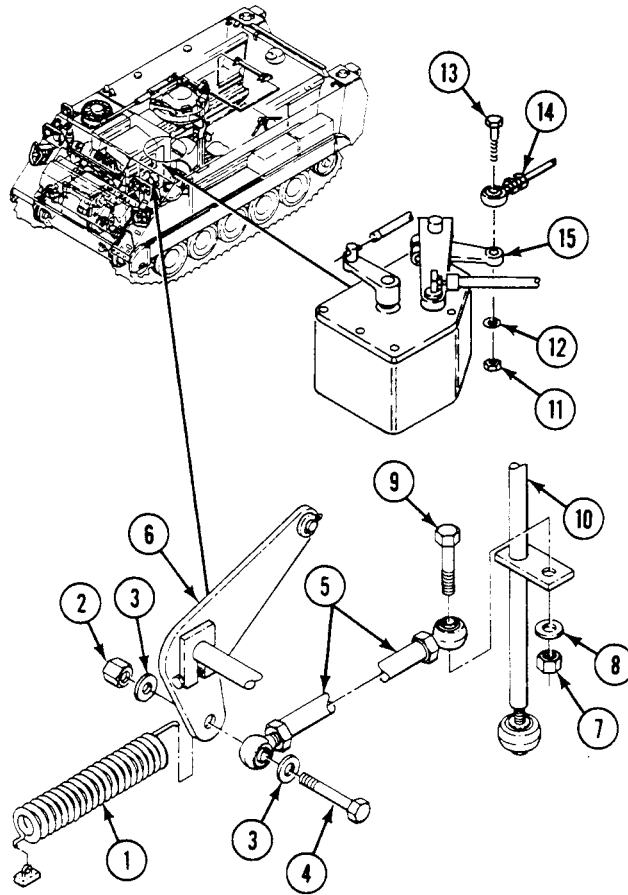

CAUTION

Use caution when removing linkage from pin due to spring on linkage.

5. Remove nut (1) and washer (2) from linkage (3). Remove linkage (3) from pin (4).
6. Remove locknut (5) and washer (6) holding bearing (7) to shaft (8). Discard locknut.
7. Hold bearing (7) and remove screw (9) from bearing. Remove washer (10), lockwasher (11) and screw (9) from bulkhead. Remove bearing (7) from shaft (8).
8. Remove shaft (8) from bearing (12).
9. Remove screw (13) from bearing (12). Remove bearing (12) from bulkhead. Remove washer (14), lockwasher (15) and screw (13) from bulkhead.
10. Remove cotter pin (16), washer (17), and pin (4) from lever (18). Discard cotter pin.

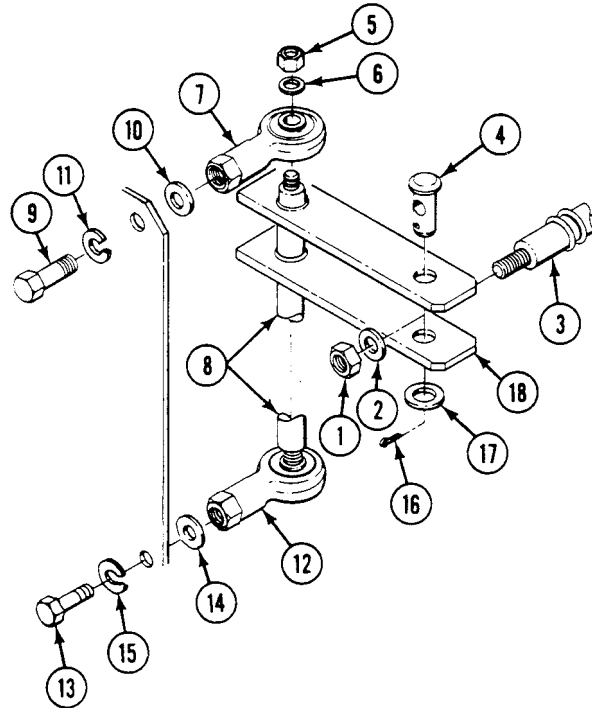

INSTALLATION

1. Install pin (4) on lever (18). Secure with washer (17) and new cotter pin (16).
2. Install bearing (7) on shaft (8). Secure with washer (6) and new locknut (5).
3. Position bearing (12) on bulkhead. Secure with washer (14), new lockwasher (15) and screw (13). Do not tighten screw at this time.
4. Install shaft (8) with bearing (7) on bearing (12). Secure bearing (7) to bulkhead with washer (10), new lockwasher (11) and screw (9).
5. Position bearing (12) for free movement of shaft (8) and tighten screw (13) on bearing (8).
6. Install link (3) through pin (4) and secure with washer (2) and nut (1). Do not tighten nut at this time.

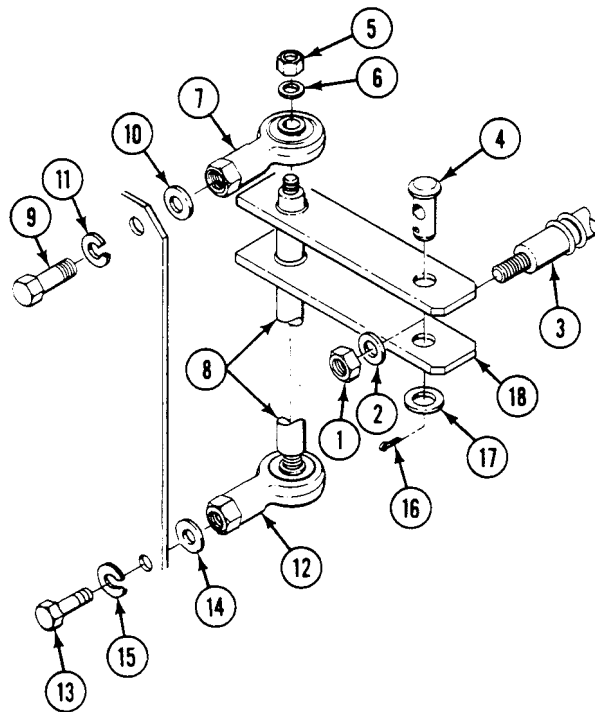

7. Install screw (1) through linkage (2) and arm (3).

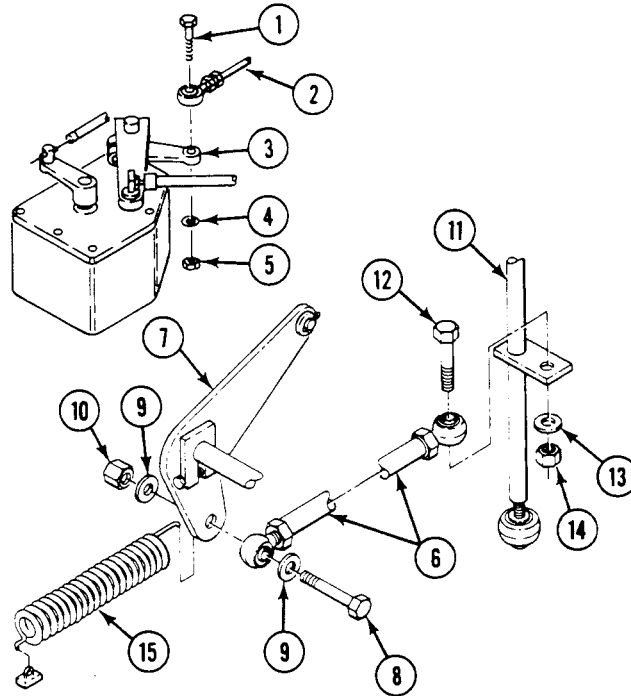

8. Tighten nut (1) at this time.

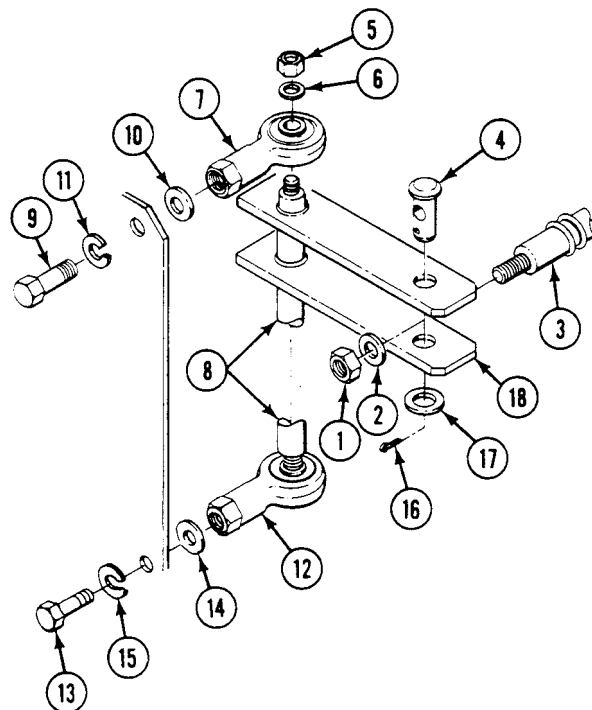

REPLACE FUEL CONTROL SHAFT AND LINKAGE — Continued**0217 00**

9. Install washer (4) and new locknut (5) on screw (1) and tighten.
10. Install link (6) on arm (7). Secure with screw (8), two washers (9) and new locknut (10).
11. Install link (6) on shaft (11). Secure with screw (12), washer (13) and new locknut (14).
12. Install spring (15) on arm (7) and bulkhead.

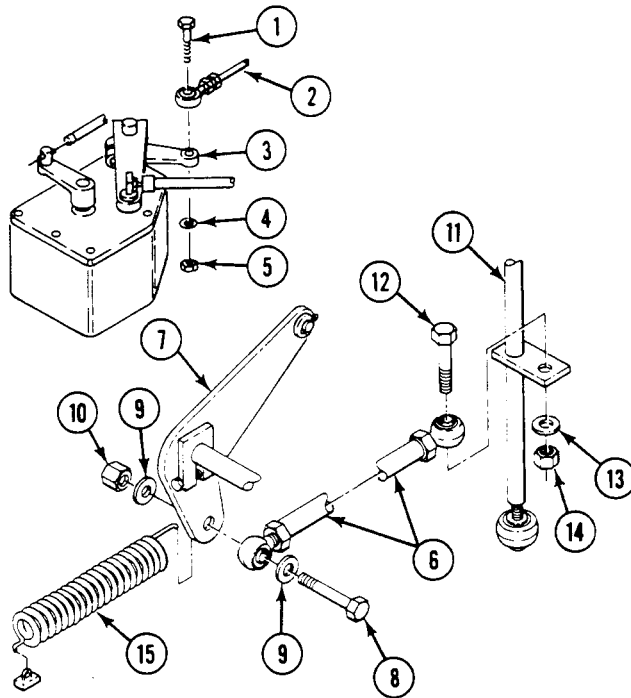
**FOLLOW-THROUGH STEPS**

1. Adjust accelerator linkage (WP 0214 00).
2. Install air intake elbow (WP 0173 00).
3. Install power plant front access cover (WP 0449 00).
4. Install driver's compartment power plant access panel (see your -10).
5. Close power plant front access door (see your -10).
6. Raise trim vane (see your -10).

END OF TASK

REPLACE THROTTLE VALVE (TV) MODULATOR AND LEVER

0218 00

THIS WORK PACKAGE COVERS:

Removal (page 0218 00-1).
 Installation (page 0218 00-4).

INITIAL SETUP:

Maintenance Level

Unit

References

See your -10

Tools and Special Tools

General Mechanic's Tool Kit (WP 0926 00, Item 65)

Equipment Condition

Engine stopped (see your -10)
 Carrier blocked (see your -10)
 Trim vane lowered (see your -10)
 Power plant front access door open (see your -10)
 Driver's power plant access panel removed (see your -10)
 Air intake elbow removed (WP 0173 00)
 Exhaust elbow removed (WP 0221 00)

Materials/Parts

Sealing compound (WP 0928 00, Item 54)
 Locknut
 Locknut
 Self-locking bolt

Personnel Required

Unit Mechanic

REMOVAL

1. Remove nut (1) from cable (2).
2. Loosen jamnut (3) on cable (2). Remove locknut (4) and washer (5) from anchor (6). Remove cable and anchor from lever (7). Discard locknut.
3. Remove anchor (6) and nut (8) from cable (2).

REPLACE THROTTLE VALVE (TV) MODULATOR AND LEVER — Continued

0218 00

4. Remove locknut (9), screw (10), and two washers (11) from lever (7) and throttle shaft (12). Remove lever from throttle shaft. Discard locknut.

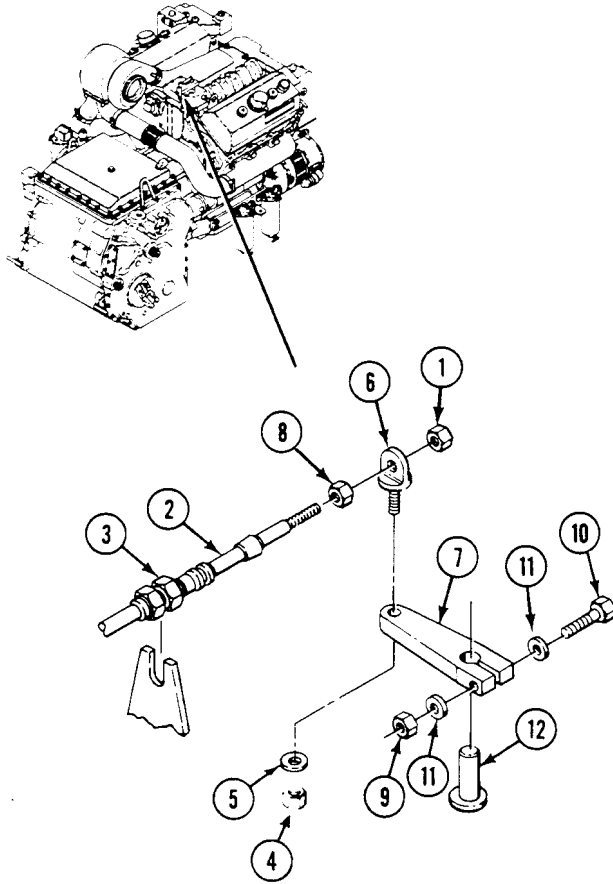

NOTE

Make sure throttle valve modulator is in idle position before removing modulator from transmission.

5. Remove self-locking bolt (1), modulator retainer (2), and throttle valve modulator (3) from transmission (4). Discard self-locking bolt.
6. Remove pipe plug (5) from pipe elbow (6), and remove pipe elbow from throttle valve pressure test port on transmission (4).

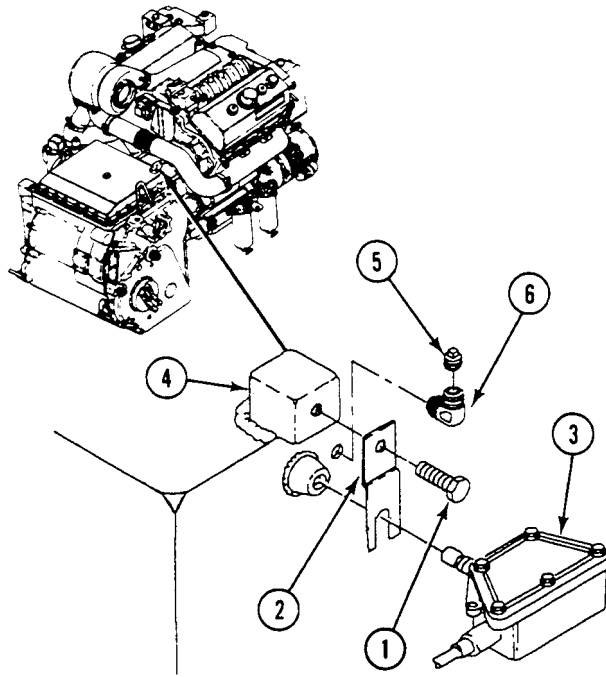

INSTALLATION

NOTE

Apply a light coat of sealing compound to male pipe threads before installation. Do not coat leading thread.

1. Install elbow (6) in throttle valve pressure test port on transmission (4) in the 1:00 to 2:00 o'clock position.
2. Install pipe plug (5) in pipe elbow (6).

CAUTION

If preformed packing comes with throttle valve modulator, discard packing. The packing is not required because there is an oil seal already installed inside the transmission, and the packing does not allow for proper fit of the modulator into the transmission.

NOTE

Make sure modulator is in idle position before installing modulator on transmission.

3. Install modulator (3) in transmission (4). Secure with retainer (2) and new self-locking bolt (1).

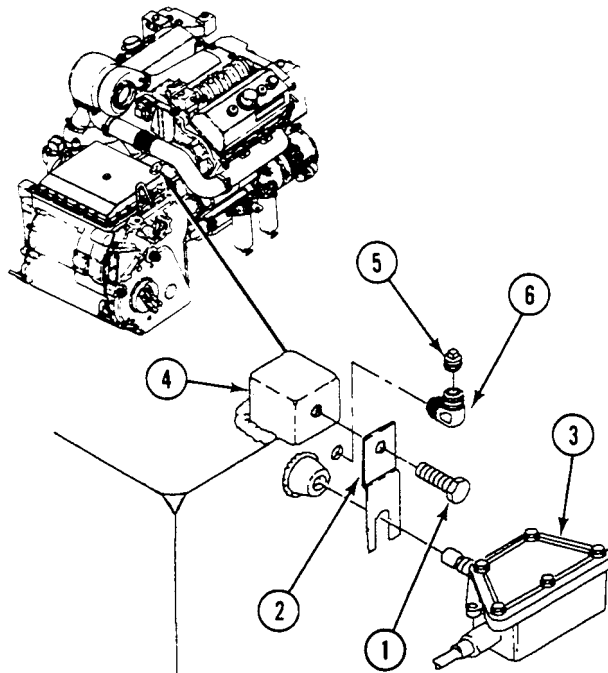

REPLACE THROTTLE VALVE (TV) MODULATOR AND LEVER — Continued

0218 00

4. Install lever (7) in throttle shaft (8). Secure with screw (9), two washers (10), and new locknut (11).
5. Install nut (12) and anchor (13) on cable (14).
6. Install anchor (13) with cable (14) in lever (7). Secure with washer (15) and new locknut (16).
7. Install nut (17) on cable (14).

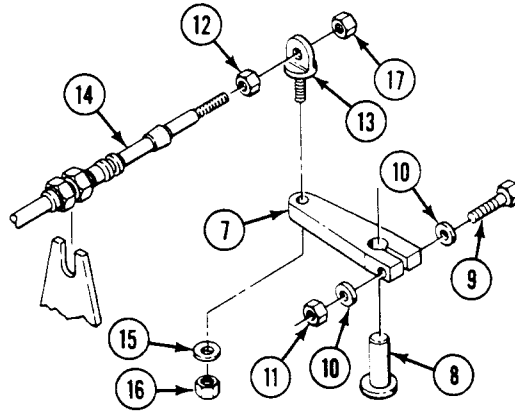

8. Tighten jamnut (1) on cable (2) 4-7/16 to 4-9/16 inch (11.27 to 11.58 cm) from bracket (3) to end of shield covering inner cable.
9. Adjust throttle valve modulator (WP 0213 00).

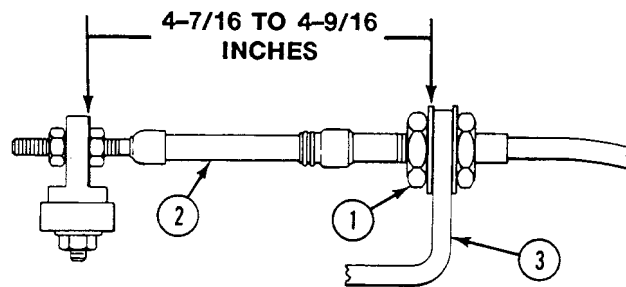

FOLLOW-THROUGH STEPS

1. Install exhaust elbow (WP 0221 00).
2. Install air intake elbow (WP 0173 00).
3. Install driver's power plant access panel (see your -10).
4. Close power plant front access door (see your -10).
5. Lower trim vane (see your -10).

END OF TASK

REPLACE HAND THROTTLE CONTROL CABLE ASSEMBLY

0219 00

THIS WORK PACKAGE COVERS:

- Removal (page 0219 00-1).
- Installation (page 0219 00-4).
- Adjustment (page 0219 00-6).

INITIAL SETUP:

Maintenance Level

Unit

References

See your -10

Tools and Special Tools

General Mechanic's Tool Kit (WP 0926 00, Item 65)

Equipment Condition

- Engine stopped (see your -10)
- Carrier blocked (see your -10)
- Trim vane lowered (see your -10)
- Power plant front access door opened (see your -10)
- Driver's power plant access panel removed (see your -10)
- Power plant front access cover removed (WP 0449 00)

Materials/Parts

- Locknut
- Lockwasher
- Tie straps

Personnel Required

Unit Mechanic

REMOVAL

1. Remove screw (1), lockwasher (2), and clamp (3) from throttle control cable (4) and weldnut (5) on upper front plate. Discard lockwasher.

2. Remove strap (6) that secures cables together. Discard strap.

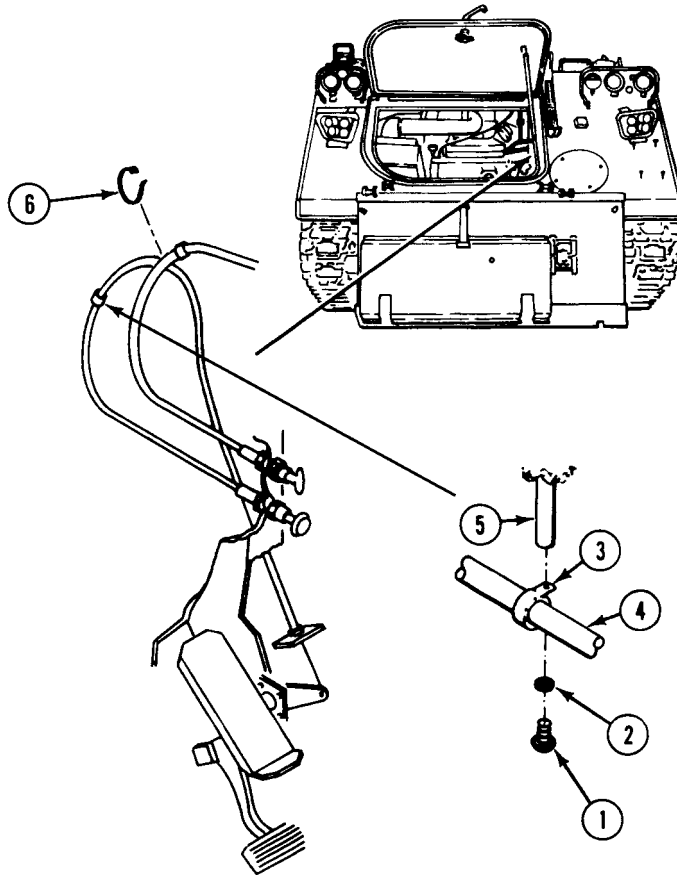

REPLACE HAND THROTTLE CONTROL CABLE ASSEMBLY — Continued

0219 00

3. Loosen set screw (1). Remove cable (2) from collar (3).
4. Remove locknut (4), washer (5), and control cable (2) from bracket (6). Discard locknut.
5. Remove washer (7) and nut (8) from control cable (2).

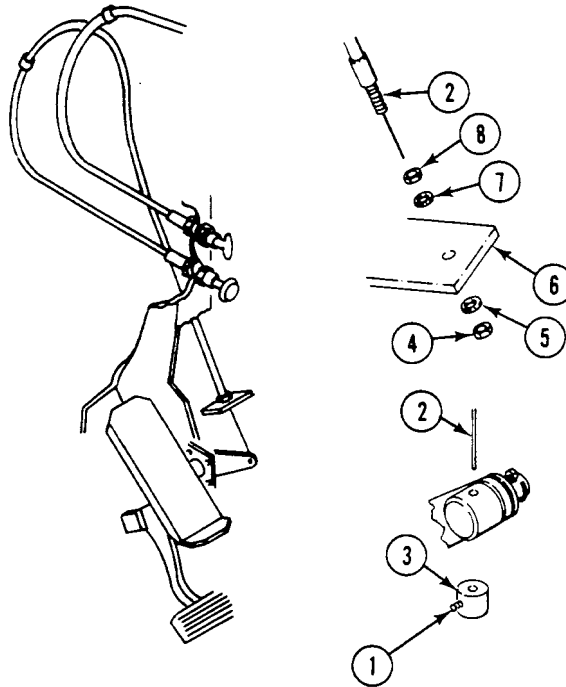

6. Remove nut (9) and washer (10) from control cable handle (11) on driver's compartment bulkhead.
7. Remove control cable (2) from driver's compartment bulkhead.

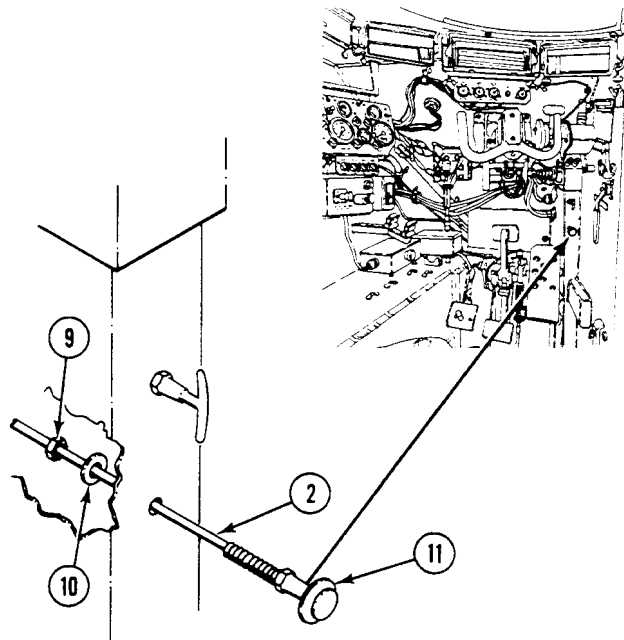

INSTALLATION

1. From driver's compartment, feed control cable (2) through mounting hole in driver's compartment bulkhead to power plant compartment.
2. Install washer (10) and nut (9) on control cable handle (11), and secure control cable (2) to driver's compartment bulkhead.

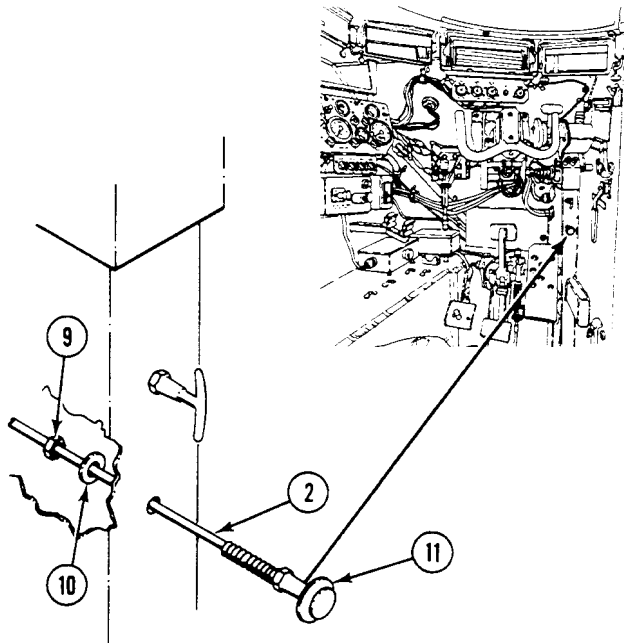

3. Install nut (12) and washer (13) on control cable (2).
4. Feed lower end of control cable (2) through mounting hole in bracket (14) at power plant compartment.

5. Install washer (15) and new locknut (16) on lower end of control cable (2). Secure cable to bracket (14).

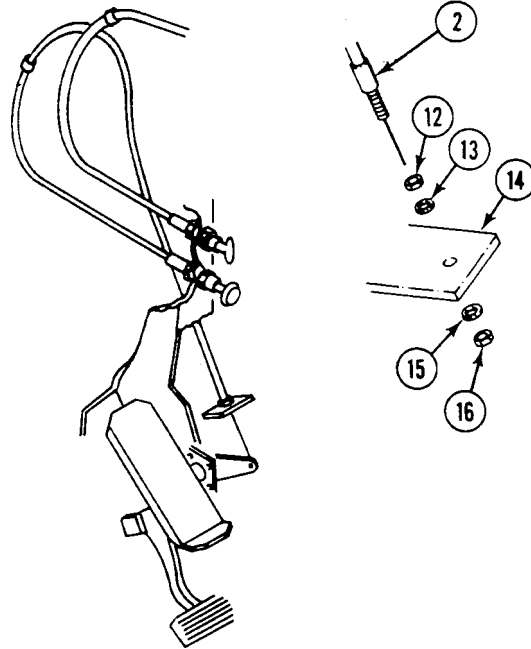

6. Install control cable (1) on collar (2). Tighten set screw (3).
7. Install clamp (4) on control cable (1) and install new lockwasher (5) and screw (6) on weldnut (7).
8. Install new strap (10) securing cables together.

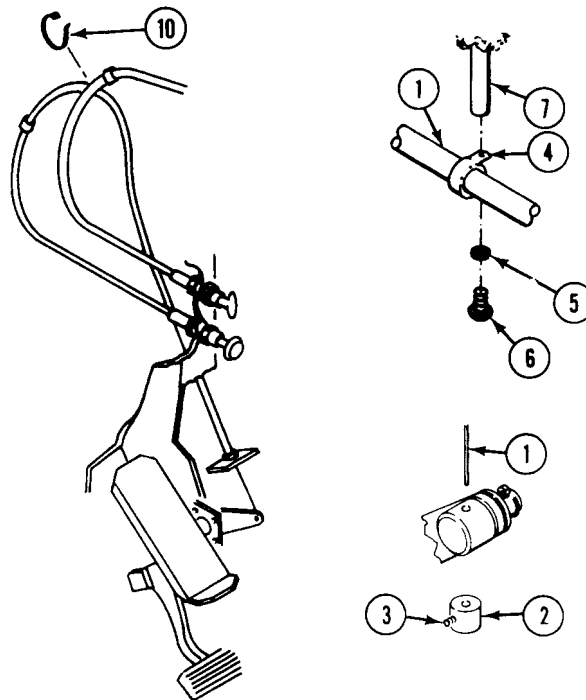

ADJUSTMENT

1. Loosen set screw (3). Push control cable handle (8) full forward.
2. Place accelerator pedal (9) in full closed throttle position. Tighten set screw (3) in collar (2).
3. Operate hand throttle control cable (1) and accelerator pedal. Check that control cable does not bind.

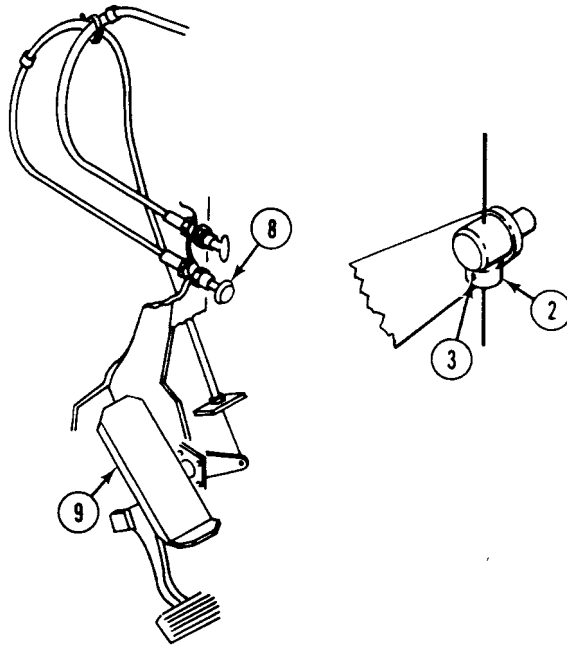
**FOLLOW-THROUGH STEPS**

1. Install power plant front access cover (WP 0449 00).
2. Install driver's power plant access panel (see your -10).
3. Close power plant front access door (see your -10).
4. Raise trim vane (see your -10).

END OF TASK

REPLACE FUEL CUTOFF CONTROL CABLE ASSEMBLY

0220 00

THIS WORK PACKAGE COVERS:

- Removal (page 0220 00-1).
- Installation (page 0220 00-4).
- Adjustment (page 0220 00-7).

INITIAL SETUP:

Maintenance Level

Unit

References

See your -10

Tools and Special Tools

General Mechanic's Tool Kit (WP 0926 00, Item 65)

Equipment Condition

- Engine stopped (see your -10)
- Carrier blocked (see your -10)
- Trim vane lowered (see your -10)
- Power plant front access door raised (see your -10)
- Driver's compartment access panel removed (see your -10)
- Air intake elbow removed (WP 0173 00)

Materials/Parts

- Cotter pin
- Lockwasher
- Tie straps

Personnel Required

- Unit Mechanic
- Helper (H)

REMOVAL

1. Remove screw (1), lockwasher (2), clamp (3) and fuel cutoff control cable (4) from weldnut (5) at upper front plate. Discard lockwasher.
2. Remove strap (6) that secures cables together. Discard strap.

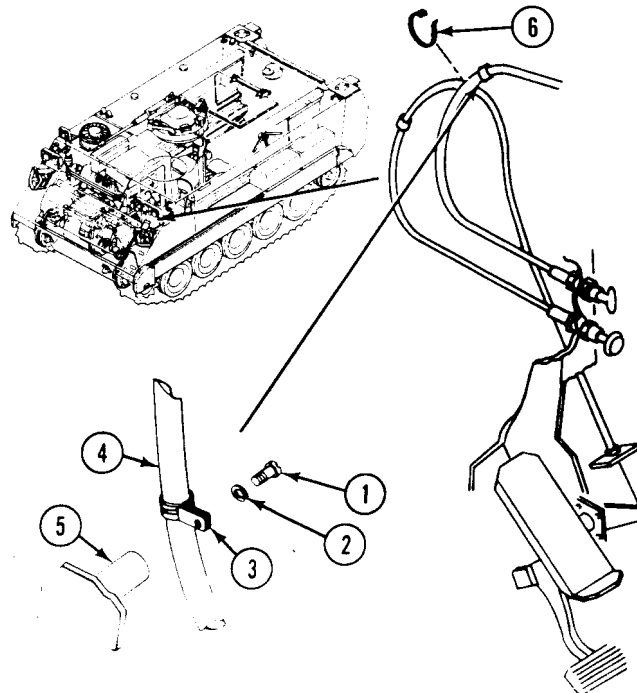

3. Remove cotter pin (1), washer (2), and headless shoulder pin (3) from engine governor fuel control arm (4). Discard cotter pin.
4. Loosen two setscrews (5). Remove two collars (6) and headless shoulder pin (3) from fuel cutoff control cable (7).
5. Remove nut (8), two washers (9), and screw (10), from clamp (11). Pull fuel cutoff control cable (7) from engine governor control housing (12).

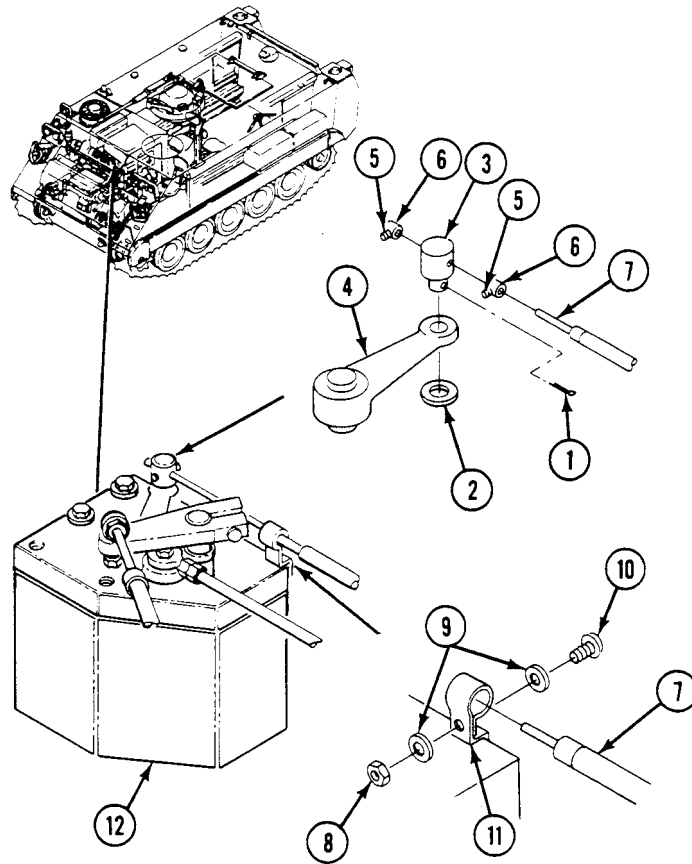

REPLACE FUEL CUTOFF CONTROL CABLE ASSEMBLY — Continued

0220 00

6. From power plant compartment, remove nut (13) and washer (14) from fuel cutoff control cable handle (15).
7. Remove fuel cutoff control cable (7) from driver's compartment bulkhead.

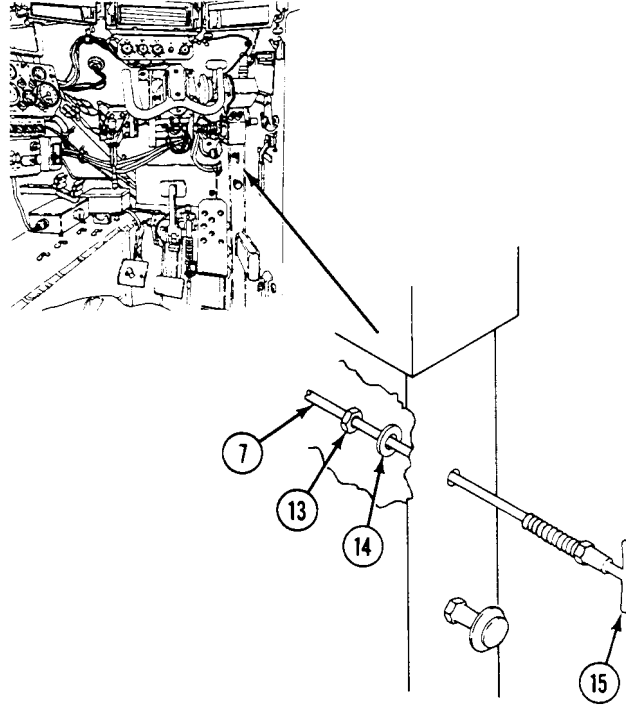

INSTALLATION

1. From driver's compartment, feed fuel cutoff control cable (7) through mounting hole in driver's compartment bulkhead to power plant compartment.
2. Install washer (14) and nut (13) on fuel cutoff control cable handle (15), and secure control cable (7) to driver's compartment bulkhead.

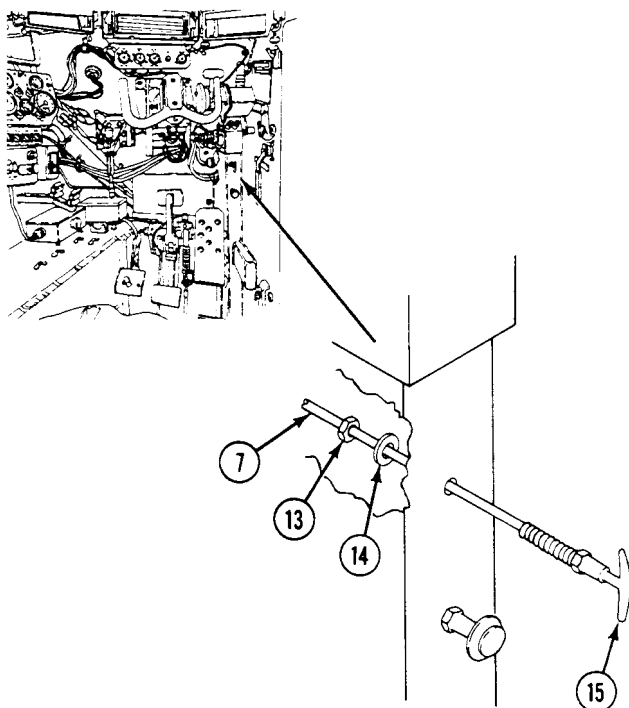

REPLACE FUEL CUTOFF CONTROL CABLE ASSEMBLY — Continued

0220 00

3. Feed fuel cutoff control cable (1) through clamp (2) on engine governor housing (3). Secure with screw (4), two washers (5), and nut (6). Do not tighten at this time.
4. Install headless shoulder pin (7) on fuel control arm (8). Install washer (9) on pin and secure with cotter pin (10).
5. Install one headless collar (11) onto cable (1), and install cable through headless shoulder pin (7). Install second collar (11) onto cable and tighten both collars with setscrew (12).
6. Position cable (1) in clamp (2). With cable pulled out, hold fuel control arm (8) in shut off position and tighten screw (4) and nut (6). Have helper assist.

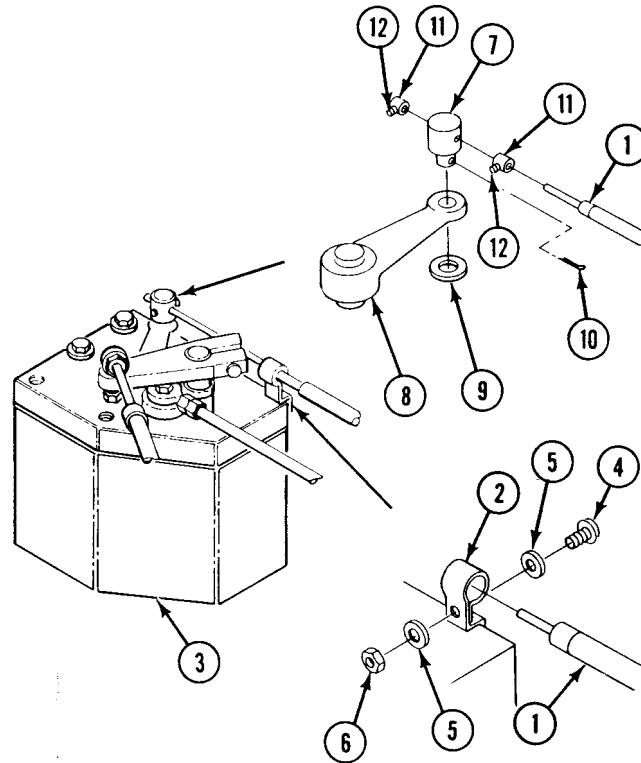

REPLACE FUEL CUTOFF CONTROL CABLE ASSEMBLY — Continued

0220 00

7. Install clamp (13), control cable (1), new lockwasher (14), and screw (15) on weldnut (16).
8. Install new strap (17) securing cables together.

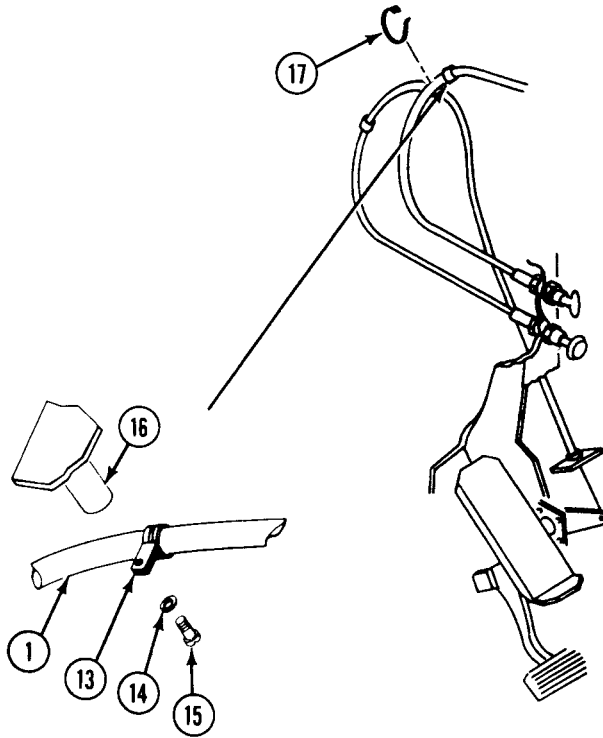

ADJUSTMENT

1. Pull fuel cutoff control cable handle (1) to full out position.

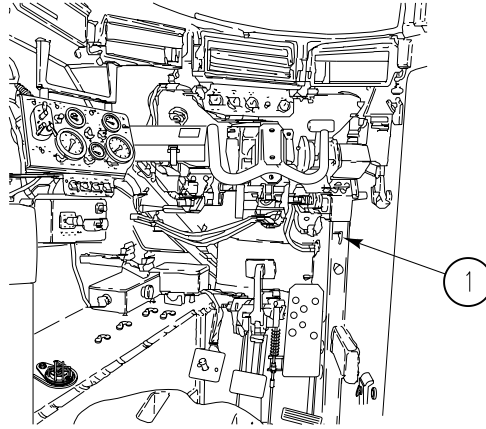

2. Rotate fuel control arm (2) to full clockwise position.
3. Reset two collars (3). Place collars (3) on each side of pin (4) and secure with two setscrews (5).

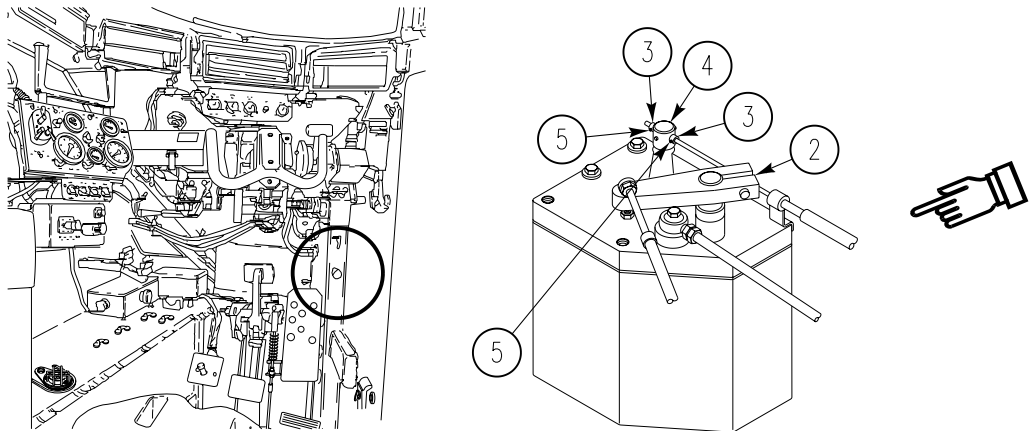

FOLLOW-THROUGH STEPS

1. Install air intake elbow (WP 0173 00).
2. Install driver's compartment access panel (see your -10).
3. Lower power plant front access door (see your -10).
4. Raise trim vane (see your -10).

END OF TASK

CHAPTER 6

UNIT MAINTENANCE INSTRUCTIONS
FOR EXHAUST SYSTEM

WORK PACKAGE INDEX

<u>Title</u>	<u>Sequence No.</u>
REPLACE ENGINE EXHAUST ELBOWS AND DOUBLE FLEX JOINT.....	0221 00
REPAIR DOUBLE FLEX EXHAUST JOINT.....	0222 00
REPLACE MUFFLER EXTENSION AND CAP.....	0223 00
REPLACE EXHAUST MUFFLER AND BRACKET.....	0224 00
REPLACE ENGINE LEFT/RIGHT EXHAUST ELBOWS.....	0225 00
REPLACE LEFT/RIGHT TURBO EXHAUST PIPE HEAT SHIELD.....	0226 00

REPLACE ENGINE EXHAUST ELBOWS AND DOUBLE FLEX JOINT

0221 00

THIS WORK PACKAGE COVERS:

Removal (page 0221 00-1).
 Installation (page 0221 00-3).

INITIAL SETUP:

Maintenance Level

Unit

References

See your -10

Tools and Special Tools

General Mechanic's Tool Kit (WP 0926 00, Item 65)
 Torque Wrench (WP 0926 00, Item 79)

Equipment Condition

Engine stopped (see your -10)
 Carrier blocked (see your -10)
 Trim vane lowered (see your -10)
 Power plant front access door opened (see your -10)
 Power plant grill raised (WP 0464 00)

Materials/Parts

Gasket (2)

Personnel Required

Unit Mechanic

REMOVAL

WARNING



Hot exhaust pipes can burn you. Let power unit cool before you start work.

1. Loosen two V-clamps (1) that secure double flex joint (2) to two exhaust elbows (3) and (4).
2. Remove clamp (5) from elbow (3) and engine turbocharger. Remove elbow from turbocharger.
3. Remove clamp (6) from elbow (4) and muffler (7). Remove elbow from muffler.
4. Remove two V-clamps (1) and double flex joint (2) from elbows (3) and (4).

5. Remove two V-clamps (1), gaskets (8), and retainers (9) from double flex joint (2). Discard gaskets.

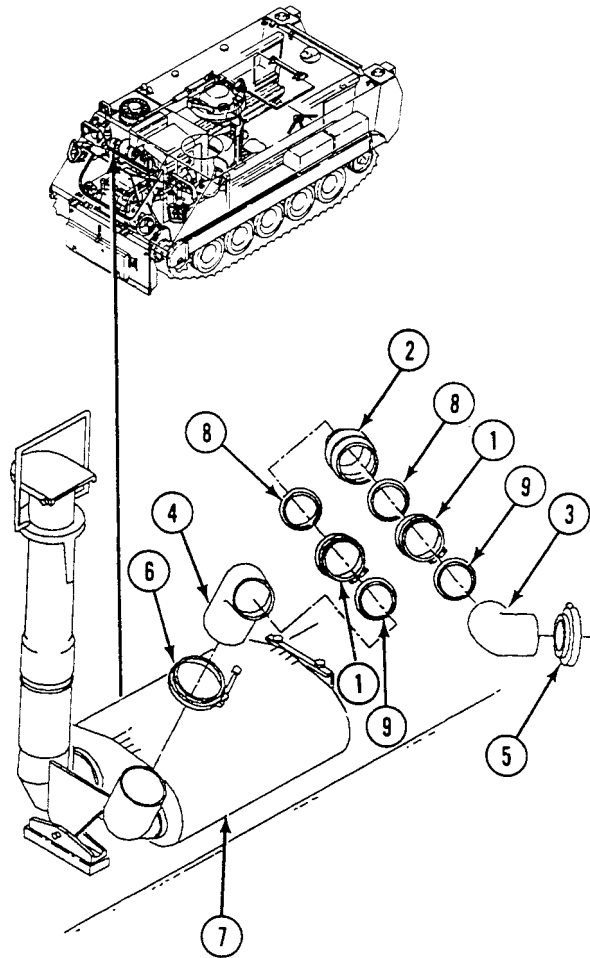

INSTALLATION

1. Install elbow (1) and clamp (2) on muffler (3).
2. Install two V-clamps (4), new gaskets (5), and retainers (6) on double flex joint (7).
3. Install double flex joint (7) and two clamps (4) on elbows (1) and (8).
4. Install elbow (8) and clamp (9) on turbocharger. Tighten clamps (2) and (9).
5. Rap clamp firmly with mallet while tightening nut and bolt on two clamps (4). **TIGHTEN NUT TO 36-53 LB-IN (4-6 N·m) TORQUE.**

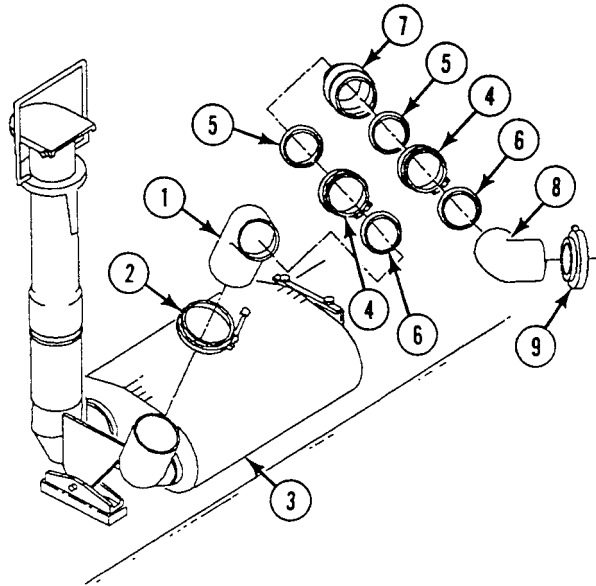
**FOLLOW-THROUGH STEPS**

1. Lower power plant grill (WP 0464 00).
2. Close power plant front access door (see your -10).
3. Raise trim vane (see your -10).

END OF TASK

REPAIR DOUBLE FLEX EXHAUST JOINT

0222 00

THIS WORK PACKAGE COVERS:

Removal (page 0222 00-1).
 Installation (page 0222 00-2).

INITIAL SETUP:

Maintenance Level

Unit

References

See your -10

Tools and Special Tools

General Mechanic's Tool Kit (WP 0926 00, Item 65)

Equipment Condition

Engine stopped (see your -10)

Materials/Parts

Gasket (2)

Carrier blocked (see your -10)

Personnel Required

Unit Mechanic

Double flex joint removed (WP 0221 00)

REMOVAL

NOTE

The double flex exhaust joint can be repaired by replacing the clamp, gasket, or retainer.

1. Remove two clamps (1), gasket retainers (2), and gaskets (3) from double flex joint (4). Discard gaskets.

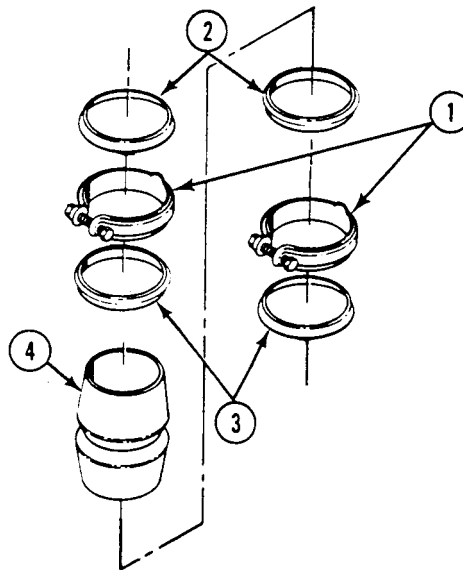

INSTALLATION

1. Install two clamps (1), gasket retainers (2), and new gaskets (3) on double flex joint (4).

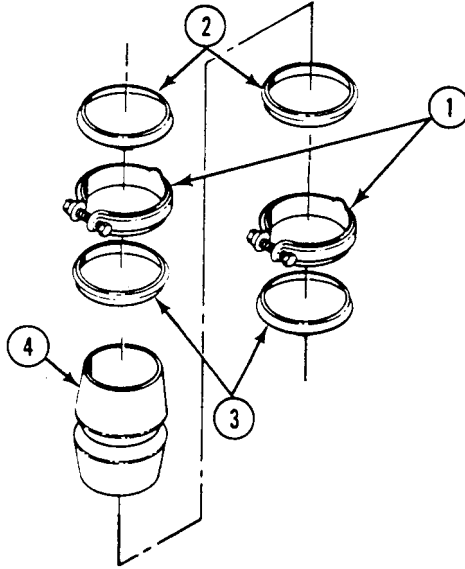
**FOLLOW-THROUGH STEPS**

1. Install double flex joint (WP 0221 00).

END OF TASK

REPLACE MUFFLER EXTENSION AND CAP

0223 00

THIS WORK PACKAGE COVERS:

Removal (page 0223 00-1).
 Installation (page 0223 00-3).

INITIAL SETUP:

Maintenance Level

Unit

References

See your -10

Tools and Special Tools

General Mechanic's Tool Kit (WP 0926 00, Item 65)

Equipment Condition

Engine stopped (see your -10)
 Carrier blocked (see your -10)
 Trim vane lowered (see your -10)
 Power plant front access door opened (see your -10)

Materials/Parts

Cotter pin
 Lockwasher (4)

Personnel Required

Unit Mechanic

REMOVAL

WARNING



Hot exhaust pipes can burn you. Let power unit cool before you start work.

1. Remove four screws (1), lockwashers (2) and washers (3) that secure exhaust extension pipe (4) to power plant grill. Remove pipe from grill and muffler (5). Discard lockwashers.

2. Remove cotter pin (6), pin (7), and cap (8) from exhaust extension pipe (4). Discard cotter pin.

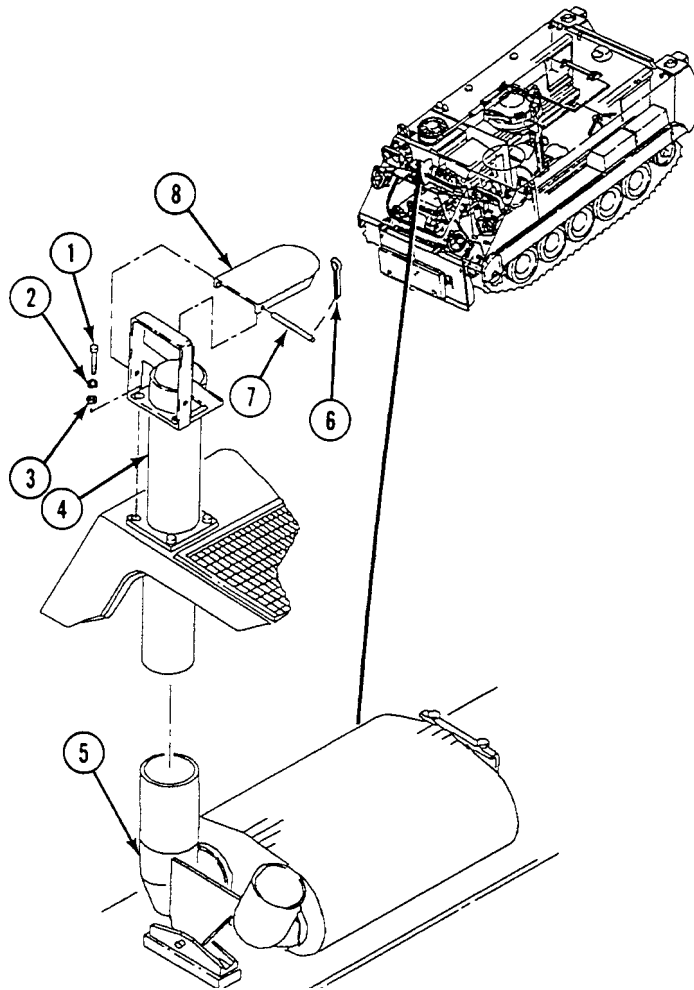

INSTALLATION

1. Install cap (8) on exhaust extension pipe (4). Secure with pin (7) and new cotter pin (6).
2. Install extension pipe (4) on muffler (5) and grill. Secure with four washers (3), lockwashers (2), and screws (1).

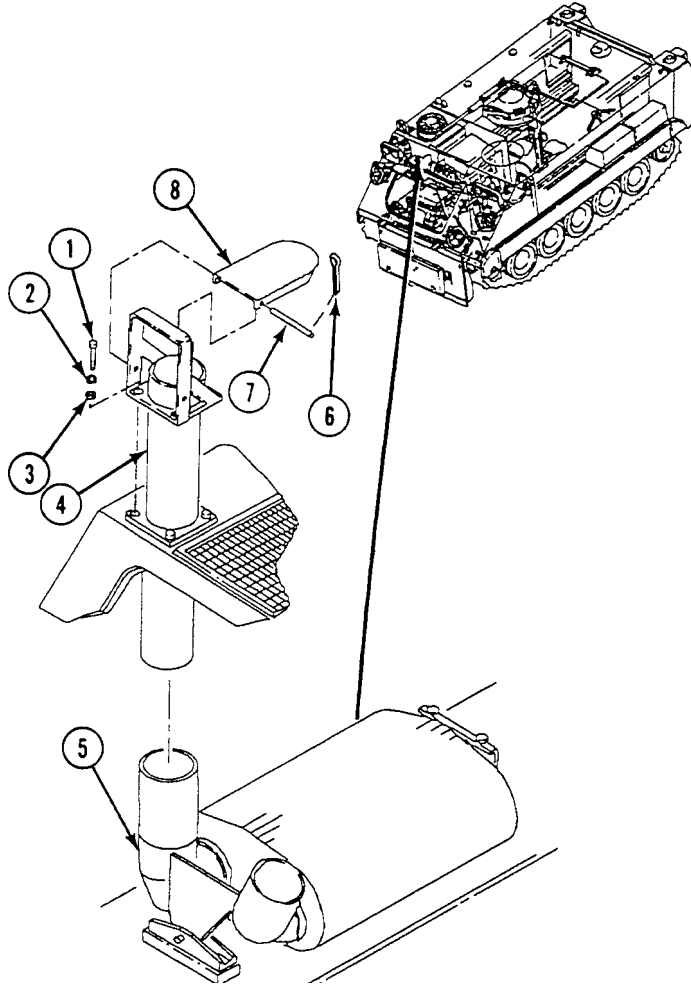
**FOLLOW-THROUGH STEPS**

1. Start engine (see your -10).
2. Check for leaks.
3. Stop engine (see your -10).
4. Close power plant front access door (see your -10).
5. Raise trim vane (see your -10).

END OF TASK

REPLACE EXHAUST MUFFLER AND BRACKET

0224 00

THIS WORK PACKAGE COVERS:

Removal (page 0224 00-1).
 Installation (page 0224 00-2).

INITIAL SETUP:

Maintenance Level

Unit

References

See your -10

Tools and Special Tools

General Mechanic's Tool Kit (WP 0926 00, Item 65)

Equipment Condition

Engine stopped (see your -10)
 Carrier blocked (see your -10)
 Trim vane lowered (see your -10)
 Power plant front access door opened (see your -10)
 Power plant grill raised (WP 0464 00)
 Exhaust elbows removed (WP 0221 00)
 Muffler extension and cap removed (WP 0223 00)

Materials/Parts

Cotter pin
 Locknut (2)
 Lockwasher (2)

Personnel Required

Unit Mechanic

REMOVAL

1. Remove two screws (1), four washers (2), and two locknuts (3) that secure muffler (4) to bracket on hull. Discard locknuts.
2. Loosen clamp (5) securing muffler (4) to connector on air cleaner.
3. Remove two screws (6), lockwashers (7), and washers (8) that secure bracket (9) to sponson. Remove muffler (4) from carrier. Discard lockwashers.
4. Remove cotter pin (10) and straight headed pin (11) from muffler (4) and bracket (9). Remove bracket. Discard cotter pin.

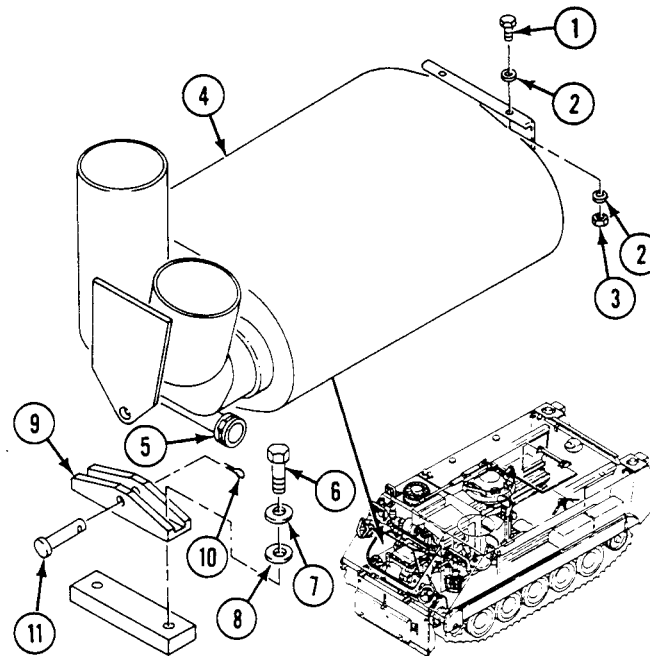

INSTALLATION

1. Install bracket (9) on muffler (4) with pin (11) and new cotter pin (10).
2. Install muffler (4) in carrier. Secure muffler and bracket (9) to sponson with two screws (6), new lockwashers (7), and washers (8).
3. Tighten clamp (5) securing muffler (4) to connector on air cleaner.
4. Secure muffler (4) to hull bracket with two screws (1), four washers (2), and two new locknuts (3).

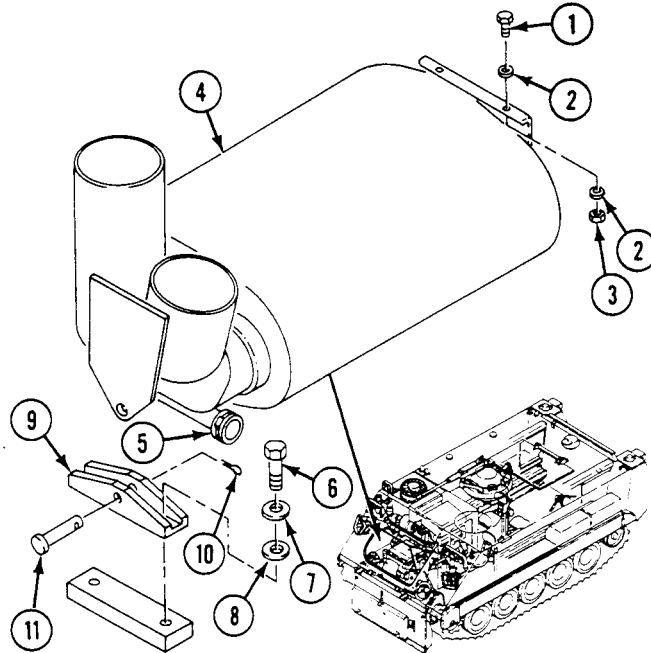
**FOLLOW-THROUGH STEPS**

1. Install muffler extension and cap (WP 0223 00).
2. Install exhaust elbows (WP 0221 00).
3. Lower power plant grill (WP 0464 00).
4. Close power plant front access door (see your -10).
5. Raise trim vane (see your -10).

END OF TASK

REPLACE ENGINE LEFT/RIGHT EXHAUST ELBOWS

0225 00

THIS WORK PACKAGE COVERS:

Removal (page 0225 00-1).
 Installation (page 0225 00-2).

INITIAL SETUP:

Maintenance Level
 Unit

Tools and Special Tools
 General Mechanic's Tool Kit (WP 0926 00, Item 65)

Personnel Required
 Unit Mechanic

References
 See your -10

Equipment Condition

Engine stopped (see your -10)
 Carrier blocked (see your -10)
 Trim vane lowered (see your -10)
 Power plant front access door opened (see your -10)
 Air cleaner removed to access right elbow (WP 0168 00)
 Driver's compartment access panel removed to access left elbow (see your -10)

REMOVAL

NOTE

Left elbow is shown only.

1. Loosen two clamps (1) and remove elbow hose (2) from air cleaner (3) and turbo (4).

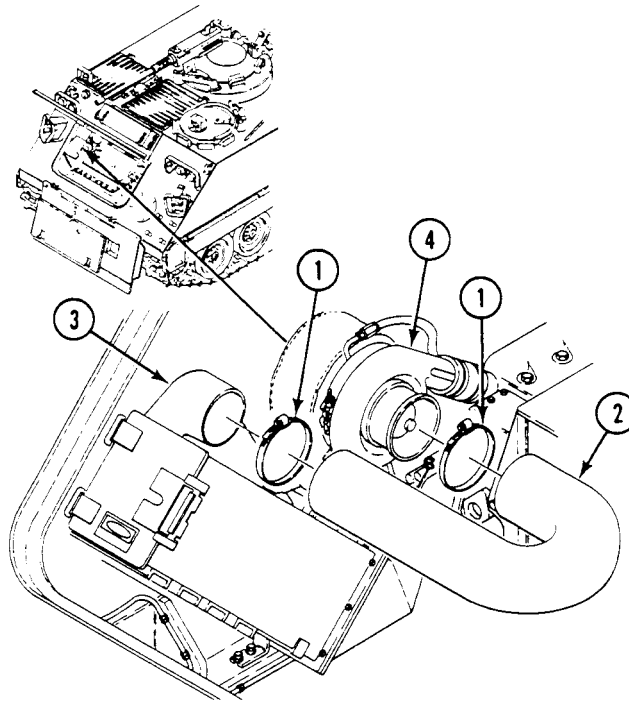

2. Remove two clamps (5) from exhaust inlet tube (6).
3. Remove exhaust inlet tube (6) from inlet tee (7) and exhaust manifold (8).

4. Remove turbo exhaust pipe heat shield (WP 0226 00).

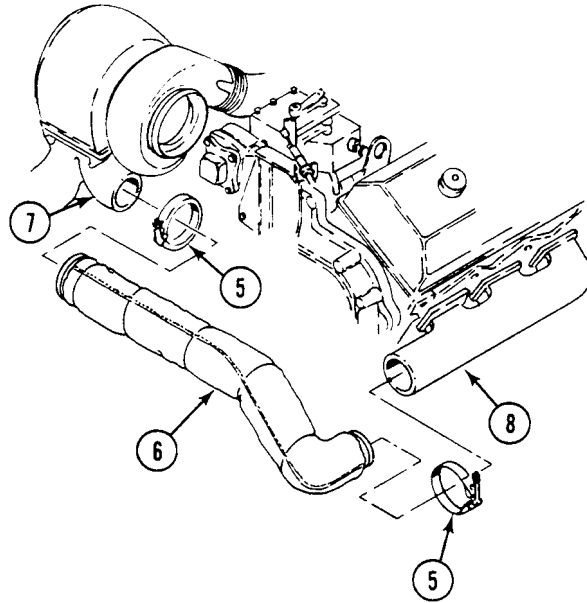

INSTALLATION

NOTE

Left elbow is shown only.

1. Install turbo exhaust pipe heat shield (WP 0226 00).
2. Install exhaust inlet tube (1) on inlet tee (2) and exhaust manifold (3).
3. Install and tighten two clamps (4) on exhaust inlet tube (1).

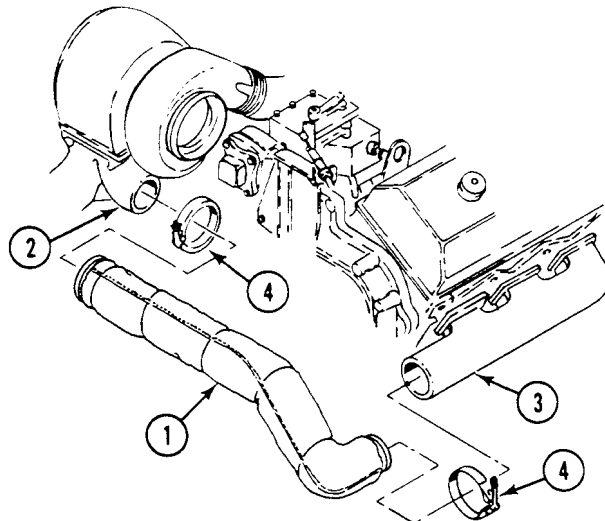

4. Install elbow hose (5) on turbo (6) and air cleaner (7). Secure with two clamps (8).

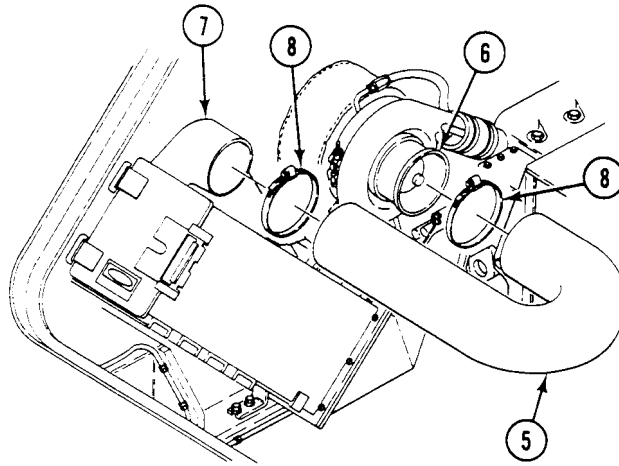

FOLLOW-THROUGH STEPS

1. Install driver's compartment access panel, if necessary (see your -10).
2. Install air cleaner, if necessary (WP 0168 00).
3. Close power plant front access door (see your -10).
4. Raise trim vane (see your -10).

END OF TASK

REPLACE LEFT/RIGHT TURBO EXHAUST PIPE HEAT SHIELD

0226 00

THIS WORK PACKAGE COVERS:

Removal (page 0226 00-1).
 Installation (page 0226 00-3).

INITIAL SETUP:

Maintenance Level

Unit

References

See your -10

Tools and Special Tools

General Mechanic's Tool Kit (WP 0926 00, Item 65)

Equipment Condition

Engine stopped (see your -10)
 Carrier blocked (see your -10)
 Trim vane lowered (see your -10)
 Power plant front access door opened (see your -10)
 Air cleaner removed if working on right elbow
 (WP 0168 00)
 Driver's compartment access panel removed if working
 on left elbow (see your -10)

Materials/Parts

Nonelectrical wire (WP 0928 00, Item 42)

Personnel Required

Unit Mechanic

REMOVAL

WARNING

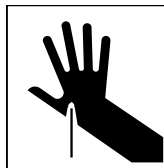

Sharp edge safety wire can cut your fingers. Make sure to twist end of wire and bend back close to the attaching hole.

NOTE

Left and right insulation covers are removed and installed the same way. Left insulation cover is shown only.

1. Cut and remove wire (1) connecting capstans (2) on insulation cover (3). Discard wire.

2. Remove insulation cover (3) from exhaust tube (4).

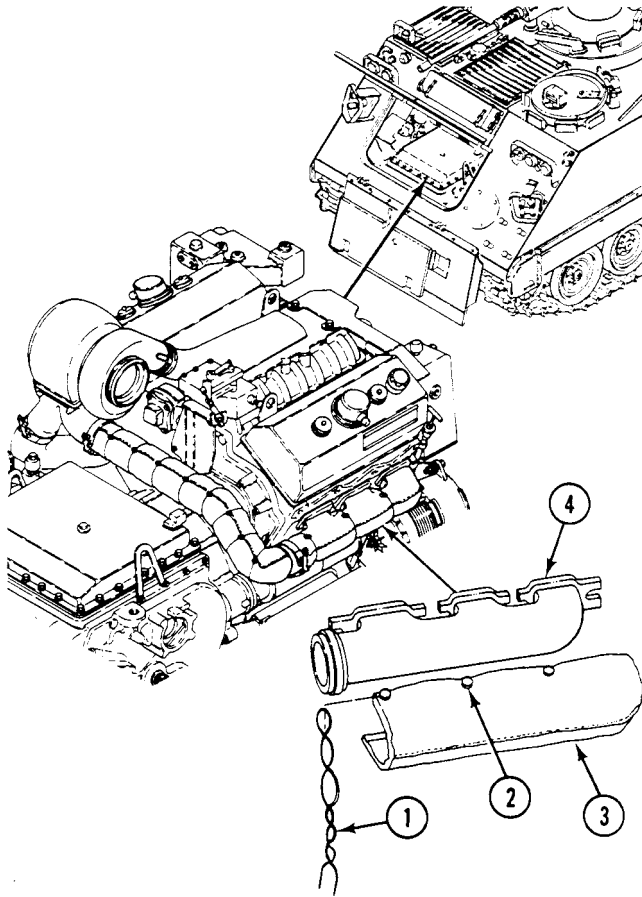

INSTALLATION

1. Wrap new insulation cover (1) around exhaust tube (2).
2. Cut new wire (3) to appropriate length and make two loops at the middle of length around capstan (4) on one half of insulation cover (1).
3. Pull wire ends (3) toward corresponding capstan (4) on other half of cover (1). Twist one wire around other to form a figure eight.
4. Cross ends of wire (3) behind second capstan (4).
5. Wind wire ends (3) to approximately 3/4 inch (19 mm) and cut off.
6. Bend wound ends back around capstan (4) hole.
7. Repeat Steps 4 - 7 to tie remaining sets of capstans (4) together. Check to make sure that seams are firmly pulled together.

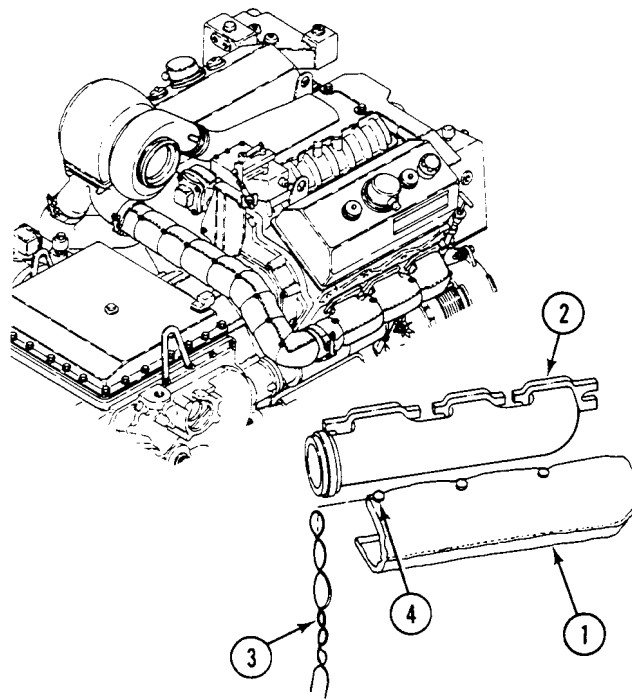
**FOLLOW-THROUGH STEPS**

1. Install driver's compartment access panel, if necessary (see your -10).
2. Install air cleaner, if necessary (WP 0168 00).
3. Close power plant front access door (see your -10).
4. Raise trim vane (see your -10).

END OF TASK

CHAPTER 7

UNIT MAINTENANCE INSTRUCTIONS
FOR COOLING SYSTEM

WORK PACKAGE INDEX

<u>Title</u>	<u>Sequence No.</u>
DRAIN AND FILL COOLING SYSTEM.....	0227 00
CLEAN RADIATOR.....	0228 00
REPLACE RADIATOR AND PARTS.....	0229 00
REPLACE AUXILIARY TANK.....	0230 00
REPLACE THERMOSTATIC FAN SPEED SWITCH (OLD CONFIGURATION).....	0231 00
REPLACE VARIABLE SPEED FAN DRIVE VALVE AND OVERRIDE SWITCH (NEW CONFIGURATION).....	0231 01
REPLACE UPPER COOLANT HOSE AND TUBE.....	0232 00
REPLACE RADIATOR OUTLET TUBE AND HOSES.....	0233 00
REPLACE BALANCE HOSE.....	0234 00
REPLACE DRAIN COCK AND HOSE.....	0235 00
REPLACE COOLANT AIR SEPARATOR.....	0236 00
REPLACE THERMOSTAT/COVER.....	0237 00
REPLACE THERMOSTAT TUBE/HOSES.....	0238 00
ADJUST COOLANT PUMP BELTS.....	0239 00
REPLACE COOLANT PUMP IDLER PULLEY/BELTS.....	0240 00
REPLACE ENGINE COOLANT PUMP.....	0241 00
ADJUST VENTILATING FAN DRIVE BELT.....	0242 00
REPLACE VENTILATING FAN DRIVE BELT.....	0243 00
REPLACE VENTILATING FAN DRIVE PULLEY.....	0244 00
REPLACE FLAT PULLEYS AND BEARINGS.....	0245 00
REPLACE IDLER ARM AND SPRING TENSIONER.....	0246 00
REPLACE VENTILATING FAN ASSEMBLY.....	0247 00
REPLACE FAN DRIVE SHAFT AND BEARING HOUSING.....	0248 00
REPLACE FAN AND GENERATOR VARIABLE SPEED DRIVE (OLD CONFIGURATION).....	0249 00
REPLACE VARIABLE SPEED FAN DRIVE ASSEMBLY (NEW CONFIGURATION).....	0249 01
REPLACE HOSES FROM THERMOSTAT TO VARIABLE SPEED DRIVE (OLD CONFIGURATION).....	0250 00
REPLACE VARIABLE SPEED FAN DRIVE CONTROLLER (NEW CONFIGURATION).....	0250 01
REPLACE TRANSMISSION OIL SUPPLY AND RETURN HOSES (OLD CONFIGURATION).....	0251 00
REPLACE HOSE FROM VARIABLE SPEED FAN DRIVE OVERRIDE SWITCH TO VSFD DRIVE (NEW CONFIGURATION).....	0251 01

DRAIN AND FILL COOLING SYSTEM

0227 00

THIS WORK PACKAGE COVERS:

Service (page 0227 00-2).

INITIAL SETUP:

Maintenance Level

Unit

Tools and Special Tools

- General Mechanic's Tool Kit (WP 0926 00, Item 65)
- Radiator filling can (WP 0926 00, Item 12)
- Suitable Container (14 gallon)
- Antifreeze and battery tester (WP 0926 00, Item 8.1)

Materials/Parts

- Antifreeze (WP 0928 00, Item 10)

Personnel Required

- Unit Mechanic

References

- See your -10
- See your PMCS
- TB 750-651

Equipment Condition

- Engine stopped (see your -10) ■
 - Carrier blocked (see your -10)
 - Power plant bottom access cover removed (WP 0450 00)
 - Power plant lower rear access panel removed (see your -10)
-

SERVICING

COMPLETE DRAIN

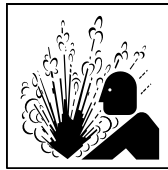
WARNING

Hot radiator coolant can burn you. Use hand to remove cap **ONLY** if cool to touch. Turn cap slowly to release pressure. Replace cap by pressing down and turning until tight.

CAUTION

Coolant in the cooling system must flow freely. If rust, scale, or sediment prevent the free flow of coolant, flush system per TB 750-651. This is to be done only as necessary.

1. Open coolant filler cap cover (1) on power plant grill (2).
2. Remove coolant filler cap (3) from auxiliary tank (4).

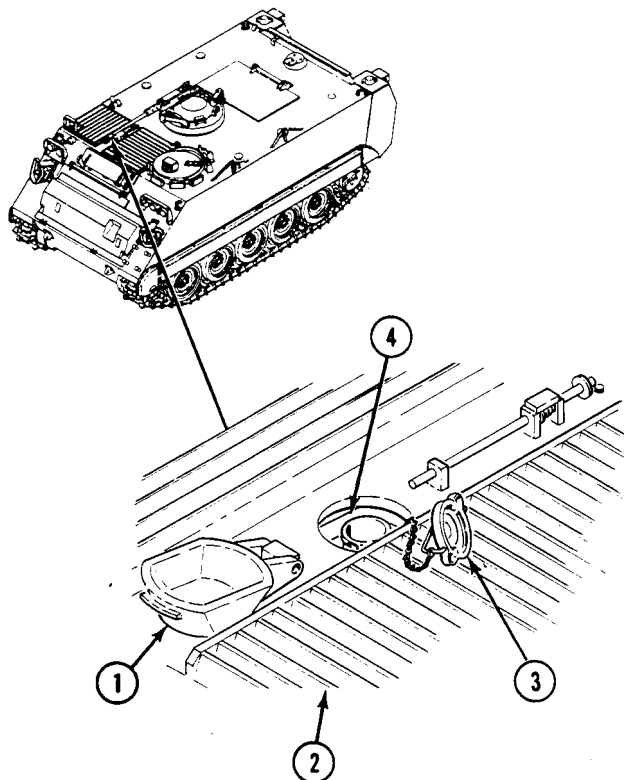

3. Place clean container under engine compartment bottom access opening.
4. Route end of drain hose (1) out through engine compartment bottom access opening.
5. Open drain cock (2) at radiator outlet tube (3) and drain hose (1).
6. After system is drained, close drain cock (2) and install engine compartment bottom access opening. Save coolant for reuse, unless check shows coolant should be changed.

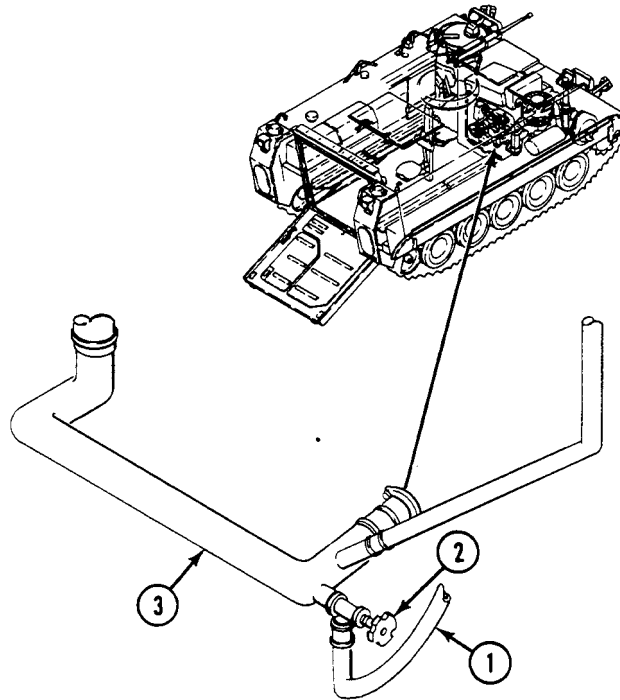

FILL COOLING SYSTEM

CAUTION

If not filling coolant system immediately, tag master switch to warn others that engine coolant has been drained.

NOTE

Use coolant in system at all times. It will reduce corrosion in engine block and cooling system parts. Ethylene glycol coolant will provide low temperature protection. Mix coolant and clean water based on protection label on container.

When filling the auxiliary tank, add coolant slowly to allow trapped air to escape.

1. Fill system with coolant. Bring coolant level to COLD mark of filler neck.
2. Install coolant filler cap (4) on auxiliary tank (5).
3. Close coolant filler cap cover (6) on power plant grill (7).

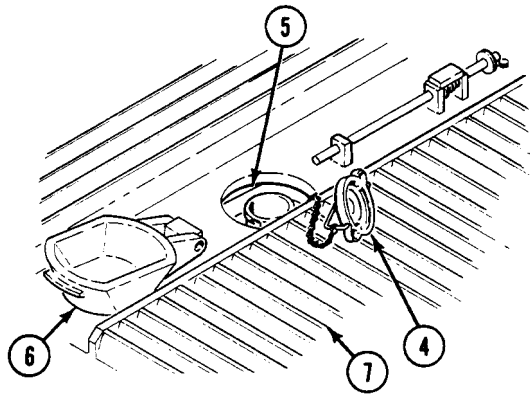
**CAUTION**

Do not operate engine if temperature is 230°F (110°C) or above. Serious engine damage will occur.

4. Start and run engine until operating temperature of 180° to 230°F (82° to 110°C) is reached.

CAUTION

If engine coolant temperature gage reading is above 230°F (110°C), stop engine (see you -10) and allow it to cool.

Check the following for cause of engine overheat:

Make sure air cleaner element is clean and installed right (see your -10).

Check fan belts (WP 0242 00) for correct adjustment.

Check radiator and air intake grill air passages. Clean and remove debris preventing free movement of air (see your -10).

Check engine oil level. Check for right grade of oil (WP 0155 00).

5. Stop engine and allow it to cool (see your -10).

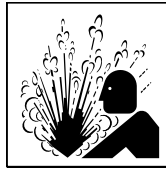
WARNING

Hot radiator coolant can burn you. Use hand to remove cap ONLY if cool to touch. Turn cap slowly to release pressure. Replace cap by pressing down and turning until tight.

6. Add coolant as necessary to bring level to COLD mark of filler neck (1). Check for leaks.

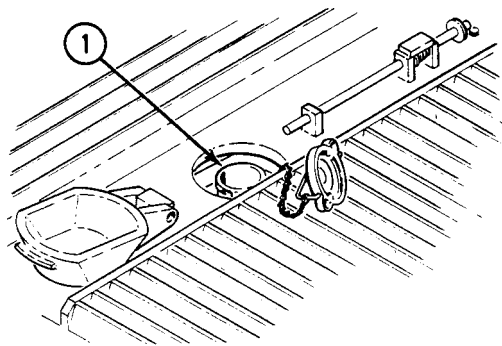
**FOLLOW-THROUGH STEPS**

1. Install power plant bottom access cover (WP 0450 00).
2. Install power plant lower rear access panel (see your -10).

END OF TASK

CLEAN RADIATOR

0228 00

THIS WORK PACKAGE COVERS:

Cleaning (page 0228 00-1).

INITIAL SETUP:

Maintenance Level

Unit

Tools and Special Tools

- General Mechanic's Tool Kit (WP 0926 00, Item 65)
- Radiator Cleaning Tool (WP 0926 00, Item 13)
- Suitable Container

Materials/Parts

- General purpose detergent (WP 0928 00, Item 35)

Personnel Required

Unit Mechanic

References

See your -10

Equipment Condition

- Engine stopped (see your -10)
- Carrier blocked (see your -10)
- Driver's power plant access panel removed (see your -10)
- Power plant upper rear access panel removed (see your -10)
- Trim vane lowered (see your -10)
- Power plant front access door opened (see your -10)
- Power plant bottom access cover removed (WP 0450 00)

CLEANING

1. Loosen two bolts (1) and clamps (2). Remove radiator access panel (3) from power plant compartment bulkhead.

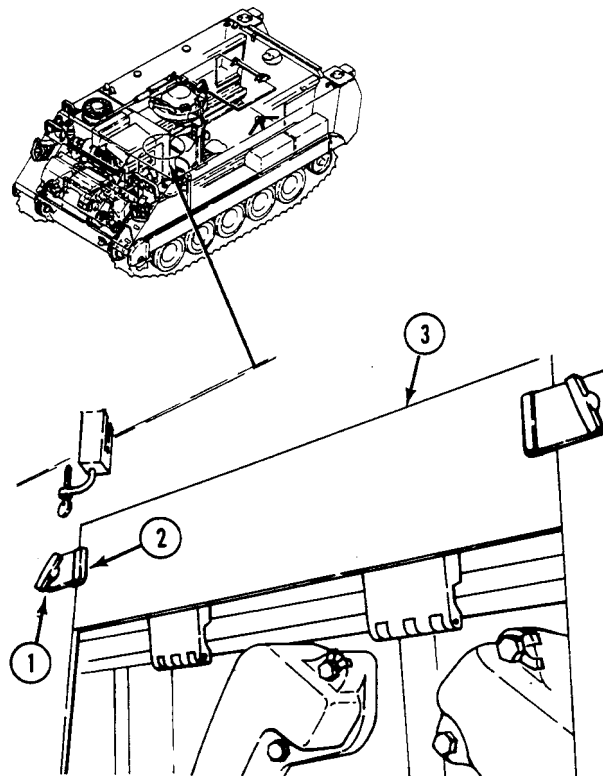

2. Release two fasteners (4) securing radiator access door (5) to radiator opening. Open door.
3. Cover exposed engine openings.
4. Mix one part detergent to five parts water in a clean container.
5. Submerge end of radiator cleaner siphon tube in detergent solution.

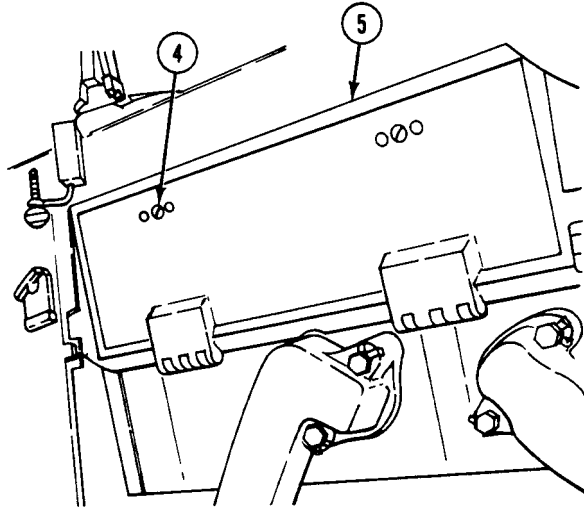

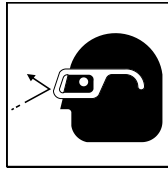
WARNING

Air pressure in excess of 30 psi (207 kpa) can injure personnel. Do not direct pressurized air at yourself or others. Always wear goggles.

6. Attach radiator cleaning tool to available air supply.
7. Clean sand, oil, and debris from radiator.
8. Rinse radiator with clear water.
9. Remove siphon hose from detergent solution.
10. Remove excess water with available air supply.
11. Uncover exposed engine openings.

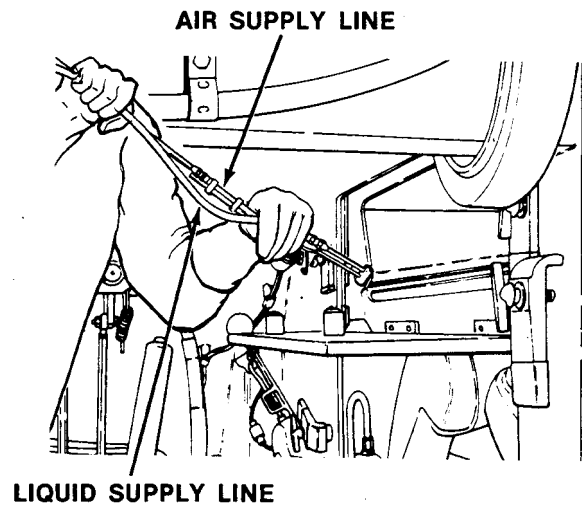

12. Secure radiator access door (1) to radiator opening with two fasteners (2).

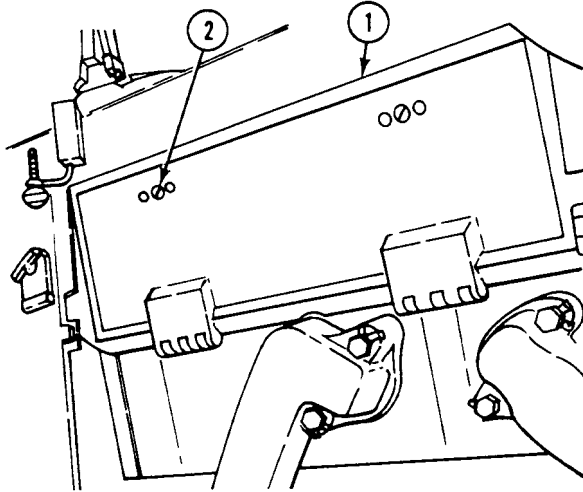

13. Secure radiator access panel (3) to power plant compartment bulkhead with two clamps (4) and bolts (5).

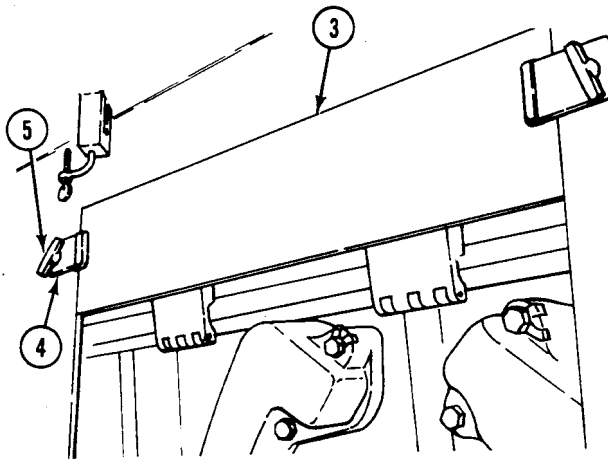

FOLLOW-THROUGH STEPS

1. Install power plant bottom access cover (WP 0450 00).
2. Install driver's power plant access panel (see your -10).
3. Install power plant rear access panel (see your -10).
4. Close power plant front access door (see your -10).
5. Raise trim vane (see your -10).

END OF TASK

REPLACE RADIATOR AND PARTS

0229 00

THIS WORK PACKAGE COVERS:

Removal (page 0229 00-2).
 Installation (page 0229 00-4).

INITIAL SETUP:

Maintenance Level

Unit

References

See your -10

Tools and Special Tools

General Mechanic's Tool Kit (WP 0926 00, Item 65)
 Sling (WP 0926 00, Item 47)
 Socket Wrench Set (WP 0926 00, Item 72)
 Torque Wrench (WP 0926 00, Item 81)

Equipment Condition

Engine stopped (see your -10)
 Carrier blocked (see your -10)
 Driver's power plant access panel removed (see your -10)
 Power plant rear upper access panel removed (see your -10)
 Power plant grill raised (WP 0464 00)
 Grill intake elbow and hose removed (WP 0174 00)
 Balance hose removed (WP 0234 00)

Materials/Parts

Adhesive (WP 0928 00, Item 4)
 Sealing compound (WP 0928 00, Item 56)
 Gasket (2)
 Mount (4)
 Key washer (4)

Personnel Required

Unit Mechanic
 Helper (H)

REMOVAL

WARNING

Radiator is heavy and can cause back injury if handled improperly. Be sure to use a hoist and helper to remove radiator.

1. Attach sling to lifting device of at least 150 lb (68 kg) capacity to radiator support lifting eyes (1). Remove 6 nuts (2), 16 washers (3), and 10 screws (4) that secure radiator supports (5) to 2 plates (6) and to power plant grill (7). Lift radiator supports and radiator (8) from power plant grill. Lower radiator to a work table or flat wooden plate and detach lifting device. Have helper assist.

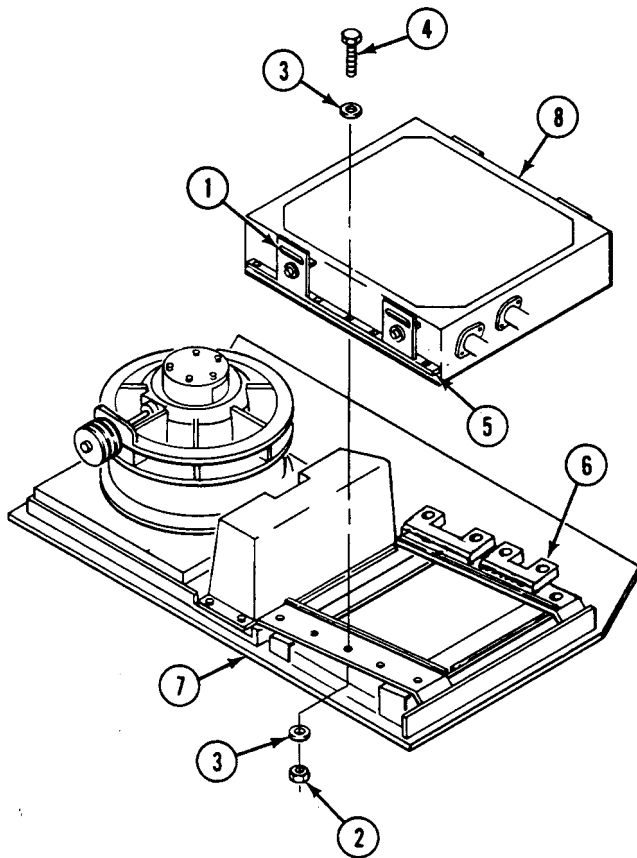

2. Remove two end seals (1) from power plant grill (2).
3. Remove two side seals (3) from power plant grill (2).

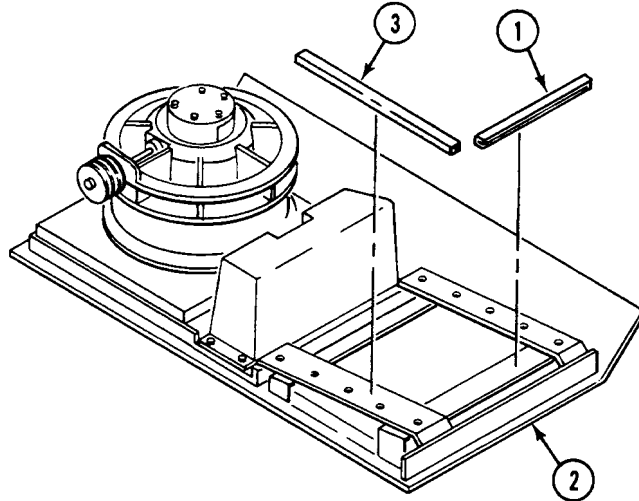

4. Remove balance hose adapter (4) from radiator (5).
5. Remove two screws (6), key washers (7), radiator outlet elbow (8), and gasket (9) from radiator (5). Discard gasket and washers.
6. Remove two screws (10), key washers (11), radiator inlet elbow (12), and gasket (13) from radiator (5). Discard gasket and washers.

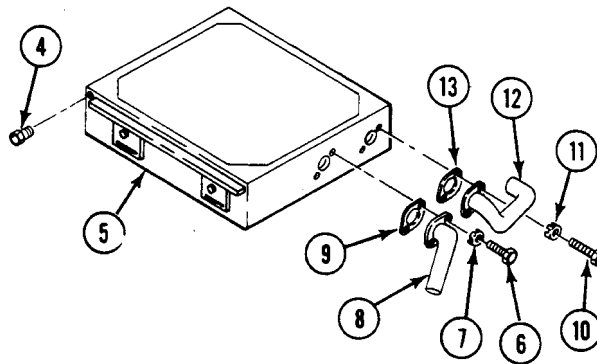

7. Remove four screws (14), washers (15), radiator supports (16), and mounts (17) from radiator (18). Discard mounts.

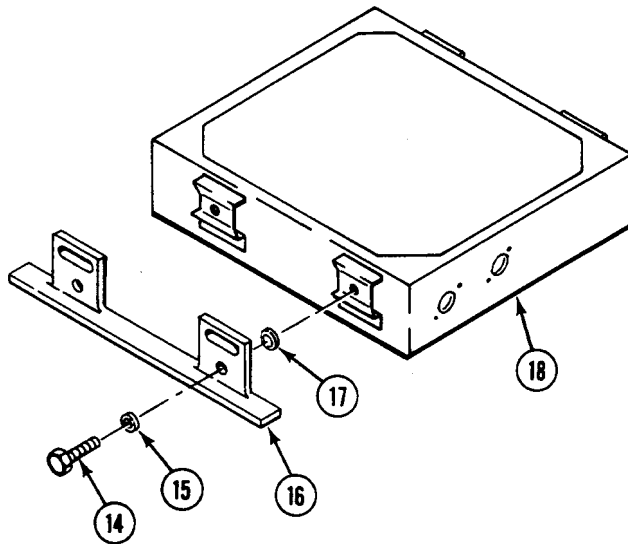

INSTALLATION

CAUTION

If installing a new radiator, make sure shipping plugs are removed.

1. Lubricate four new mounts (17) with water. Install mounts on two radiator supports (16).
2. Install two radiator supports (16) on radiator (18). Secure with four screws (14) and washers (15). **TIGHTEN SCREWS TO 360-420 LB-IN (41-48 N·m) TORQUE.**

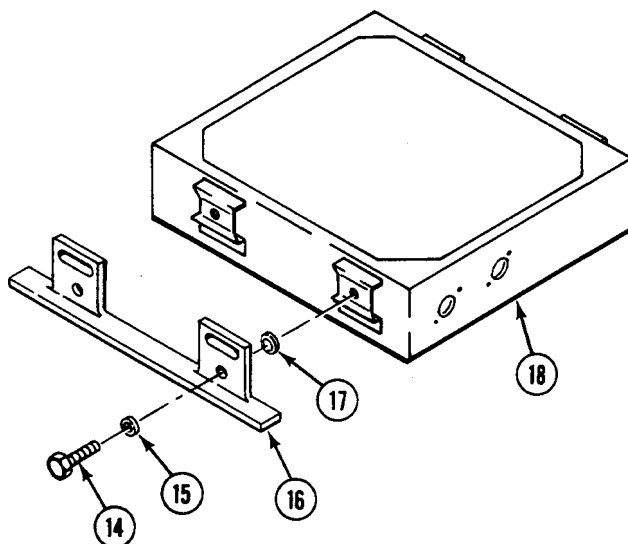

3. Apply a thin coat of sealing compound to both sides of new gaskets (1) and (8) and external threads of adapter (2).
4. Install radiator inlet elbow (3) and new gasket (1) on radiator (4). Secure with two screws (5) and new key washers (6).
5. Install radiator outlet elbow (7) and new gasket (8) on radiator (4). Secure with two screws (9) and new key washers (10).
6. Install balance hose adapter (2) on radiator (4).

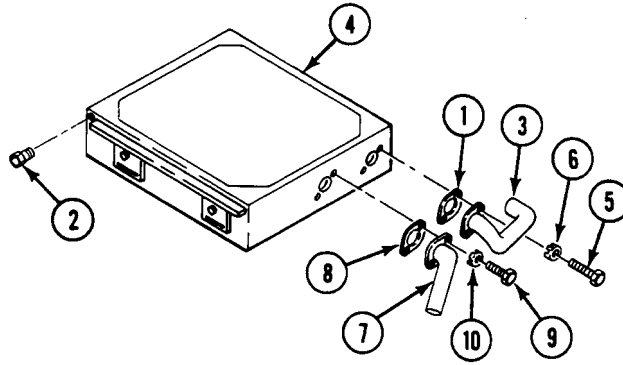

7. Apply thin coat of adhesive sealant to mounting surfaces of seals (11) and (13).
8. Install two side seals (11) on power plant grill (12).
9. Install two end seals (13) on power plant grill (12).

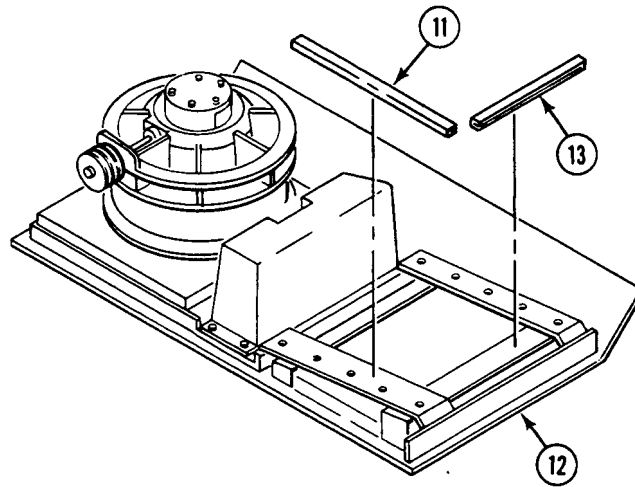

REPLACE RADIATOR AND PARTS — Continued**0229 00**

10. Attach a lifting device of at least 150 lb (68 kg) capacity to radiator support eyes (14). Lift and place radiator on power plant grill (15) between two end seals (13) and side seals (11).
11. Align mounting holes (16) of two radiator supports (17) to two plates (18) and power plant grill (15). Secure radiator (19) on plates (18) with four screws (20) and washers (21). Secure radiator on power plant grill with 6 screws (20), 12 washers (21), and 6 nuts (22).

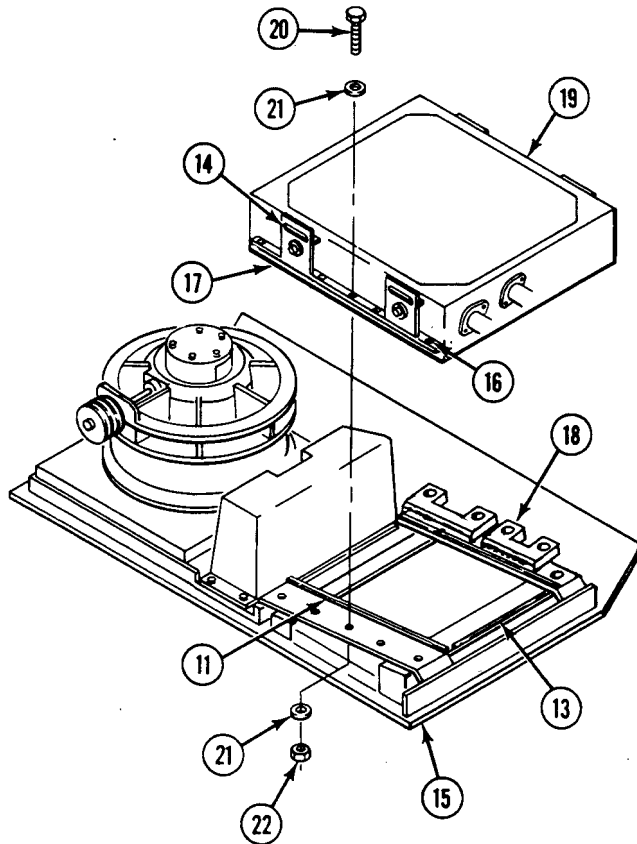
**FOLLOW-THROUGH STEPS**

1. Install balance hose (WP 0234 00).
2. Install grill intake elbow and hose (WP 0174 00).
3. Lower power plant grill (WP 0464 00).
4. Install power plant rear access panel (see your -10).
5. Install driver's power plant access panel (see your -10).

END OF TASK

REPLACE AUXILIARY TANK

0230 00

THIS WORK PACKAGE COVERS:

Removal (page 0230 00-1).
 Installation (page 0230 00-2).

INITIAL SETUP:

Maintenance Level

Unit

References

See your -10

Tools and Special Tools

General Mechanic's Tool Kit (WP 0926 00, Item 65)
 Torque wrench (WP 0926 00, Item 83)

Equipment Condition

Engine stopped (see your -10)
 Carrier blocked (see your -10)
 Power plant grill raised (WP 0464 00)
 Intake grill elbow and hose removed (WP 0174 00)
 Balance hose removed (WP 0234 00)

Materials/Parts

Sealing compound (WP 0928 00, Item 56)
 Gasket
 Lockwasher (4)

Personnel Required

Unit Mechanic

REMOVAL

1. Remove four screws (1), washers (2), and auxiliary tank (3) from power plant grill (4).
2. Remove three elbows (5), (6) and (7) from auxiliary tank (3).

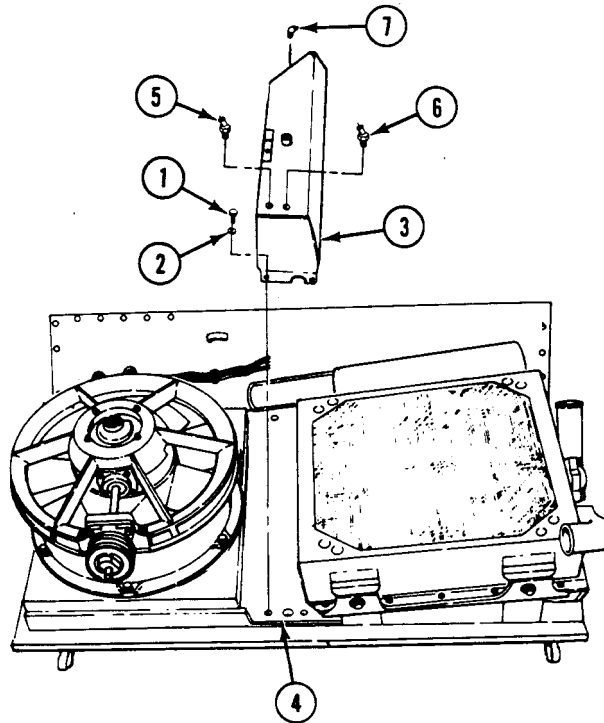

REPLACE AUXILIARY TANK — Continued**0230 00**

3. Remove screw (8), washer (9), lockwasher (10), bracket (11), two hooks (12), and filler cap (13) from filler neck (14). Discard lockwasher.
4. Remove three screws (15), washers (16), lockwashers (17), filler neck (14), and gasket (18) from auxiliary tank (3). Discard gasket and lockwashers.

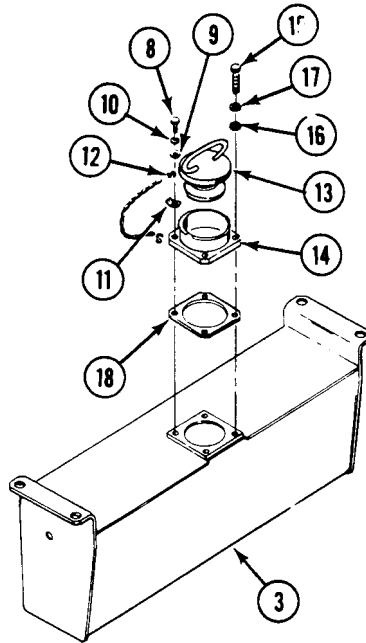
**INSTALLATION**

1. Apply thin coat of sealing compound to both sides of new gasket (1).
2. Install gasket (1) and filler neck (2) on auxiliary tank (3). Secure with three screws (4), washers (5), and new lockwashers (6).

3. Install bracket (7), two hooks (8), chain (9), and filler cap (10) on filler neck (2). Secure with screw (11), washer (12), and new lockwasher (13).

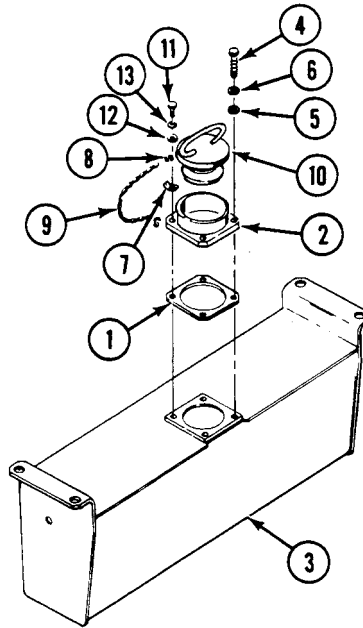

4. Apply thin coat of sealing compound to external threads of three elbows (14), (15), and (17).
5. Secure three elbows (14), (15), and (17) to auxiliary tank (3).
6. Install auxiliary tank (3) on power plant grill (17). Secure with four screws (18) and washers (19). **TIGHTEN SCREWS TO 264-288 LB-IN (30-32 N·m) TORQUE.**

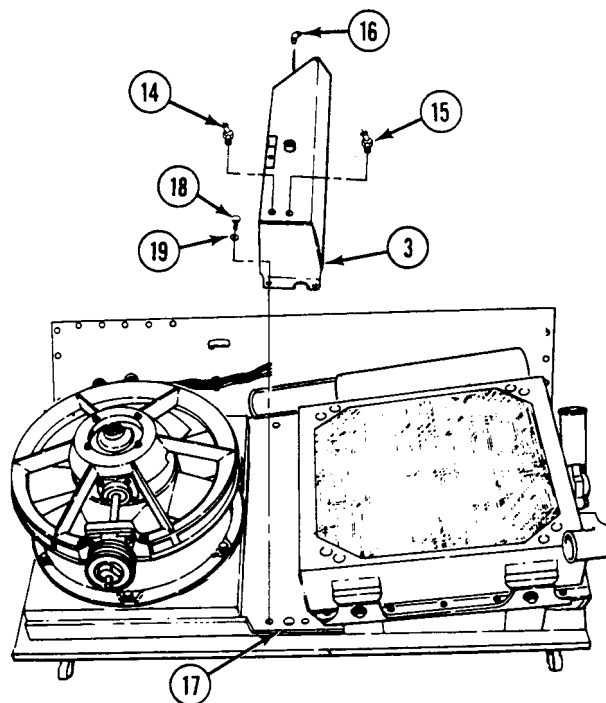

FOLLOW-THROUGH STEPS

1. Install balance hose (WP 0234 00).
2. Install grill intake elbow and hose (WP 0174 00).
3. Lower power plant grill (WP 0464 00).

END OF TASK

REPLACE THERMOSTATIC FAN SPEED SWITCH (OLD CONFIGURATION)

0231 00

THIS WORK PACKAGE COVERS:

Removal (page 0231 00-1).
 Installation (page 0231 00-3).

INITIAL SETUP:

Maintenance Level

Unit

Personnel Required

Unit Mechanic

Tools and Special Tools

General Mechanic's Tool Kit (WP 0926 00, Item 65)

References

See your -10

Materials/Parts

Sealing compound (WP 0928 00, Item 56)

Packing

Packing

Packing

Packing

Equipment Condition

Engine stopped (see your -10)

Carrier blocked (see your -10)

Power plant upper rear access panel removed (see your -10)

REMOVAL

1. Remove oil supply hose (1) from elbow (2) on thermostatic switch (3).
2. Remove elbow (2) and packing (4) from switch (3). Discard packing.

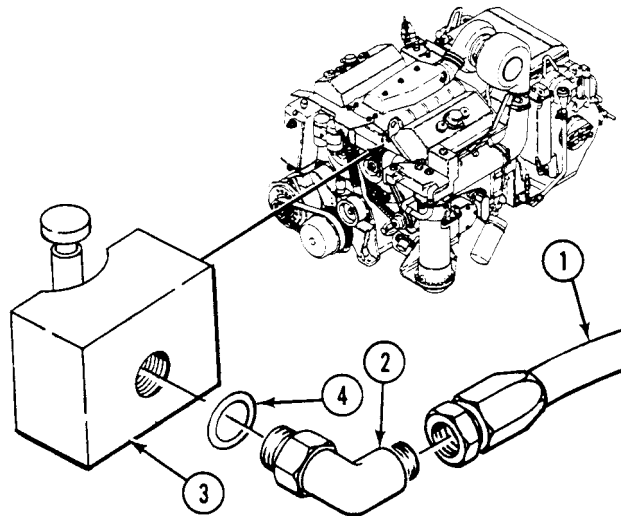

3. Remove two hoses (5) and (6) from adapters (7) and (8).
4. Remove adapters (7) and (8) and two packings (9) and (10) from switch (3). Discard packings.
5. Remove switch (3) and packing (11) from power plant (12). Discard packing.

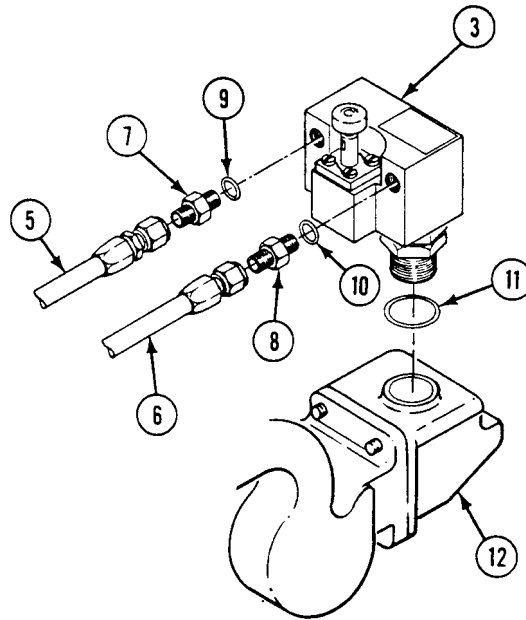

INSTALLATION

1. Apply thin coating of sealing compound to threads of switch (3).
2. Install switch (3) and new packing (11) on power plant (12).
3. Install adapters (7) and (8) and two new packings (9) and (10) on switch (3).
4. Install two hoses (5) and (6) on adapters (7) and (8).

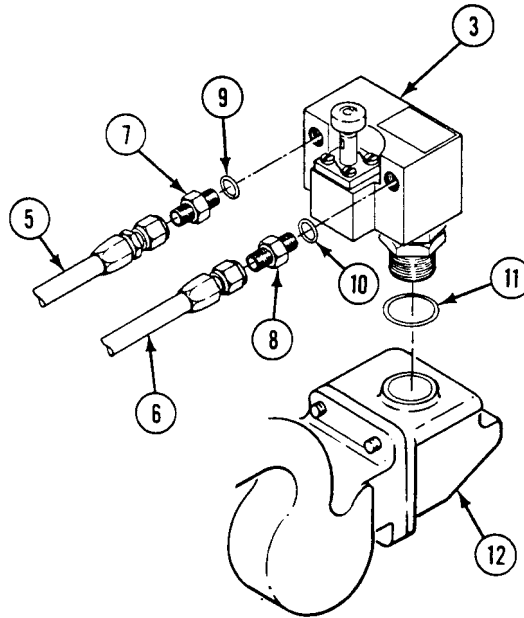

REPLACE THERMOSTATIC FAN SPEED SWITCH (OLD CONFIGURATION) — Continued**0231 00**

5. Install new packing (1) and elbow (2) on switch (3).
6. Install oil supply hose (4) on elbow (2).

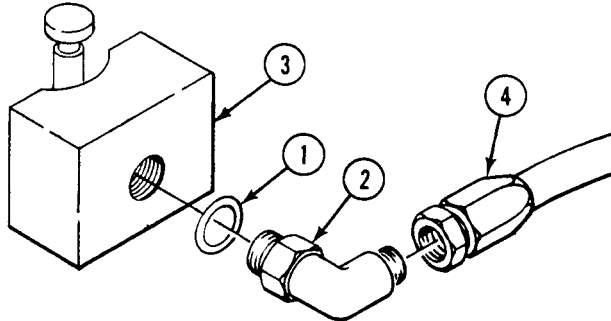
**FOLLOW-THROUGH STEPS**

1. Install power plant upper rear access panel (see your -10).

END OF TASK

**REPLACE VARIABLE SPEED FAN DRIVE VALVE AND OVERRIDE SWITCH
(NEW CONFIGURATION)**

0231 01**THIS WORK PACKAGE COVERS:**

Removal (page 0231 01-1)

Installation (page 0231 01-2)

INITIAL SETUP:Maintenance Level

Unit

Tools and Special Tools

General Mechanic's Tool Kit (WP 0926, Item 65)

Materials/Parts

Packing, preformed

Packing, preformed

Packing, preformed

Lockwashers (2)

Lockwashers (2)

Wiping rag (WP 0928 00, Item 65)

Personnel Required

Unit Mechanic

References

See your -10

Drawing 12474780

Drawing 12474790

Drawing 12474797

Equipment Conditions

Engine stopped (see your -10)

Carrier blocked (see your -10)

Power plant rear access panel removed

Battery ground strap disconnected (WP 0337 00 or WP 0338 00)

REPLACE VARIABLE SPEED FAN DRIVE VALVE AND OVERRIDE SWITCH (NEW CONFIGURATION) - Continued

0231 01

REMOVAL

1. Remove two screws (1), lockwashers (2), and bracket (3) (with valve and switch) from power plant (4). Discard lockwashers.
2. Remove two screws (5), lockwashers (6), and valve (7) from bracket (3). Discard lockwashers.
3. Remove oil supply hose (8) from elbow (9) on valve (7). Cover hose end with any appropriate material to prevent oil leaking from hose.
4. Remove elbow (9) and packing (10) from valve (7). Discard packing.
5. Remove lube hose (11) from elbow (12). Cover hose end with any appropriate material to prevent oil from leaking from hose.
6. Remove elbow (12) and packing (13) from valve (7). Discard packing.
7. Remove nut (14), lockwashers (15), and override switch (16) from bracket (3).
8. Tag and disconnect two leads (17) and (18) from override switch (16).

NOTE

Perform step 9 only if fitting and packing are leaking and tightening the fitting does not work.

9. Remove fitting (19) and packing (20) from power plant (4). Discard packing.

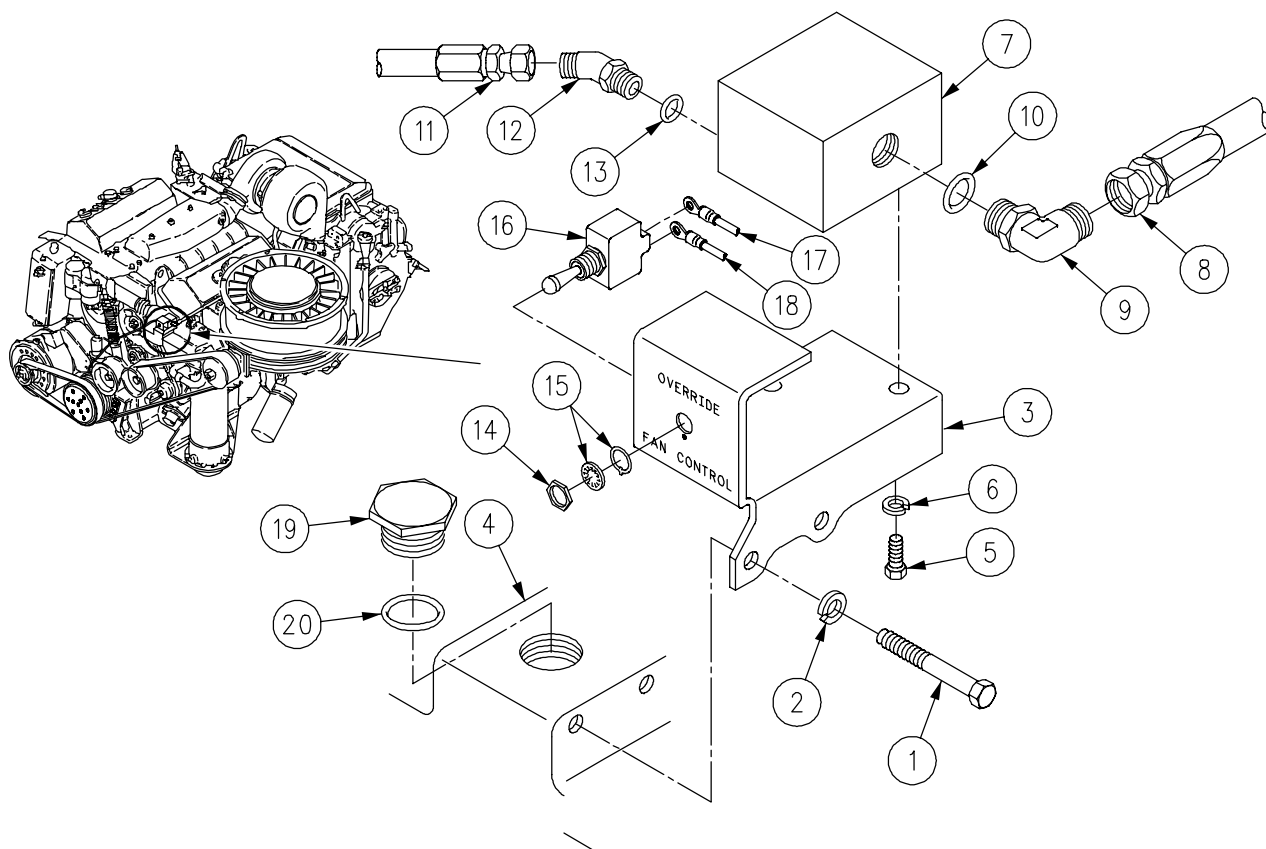

REPLACE VARIABLE SPEED FAN DRIVE VALVE AND OVERRIDE SWITCH (NEW CONFIGURATION) - Continued

0231 01

INSTALLATION
NOTE

Perform step 1 only if fitting and packing were removed in step 9.

1. Install new packing (20) and fitting (19) on power plant (4).
2. Connect two leads (17) and (18) to override switch (16). Remove tags on leads.
3. Install override switch (16), lockwashers (15), and nut (14) on bracket (3).
4. Install new packing (13) and elbow (12) on valve (7).
5. Remove cover from hose end. Install lube hose (11) on elbow (12).
6. Install new packing (10) and elbow (9) on valve (7).
7. Remove cover from hose end. Install oil supply hose (8) on elbow (9) on valve (7).
8. Install valve (7), two new lockwashers (6), and screws (5) on bracket (3).
9. Install bracket (3) (with valve and switch), two lockwashers (2), and screws (1) on power plant (4).

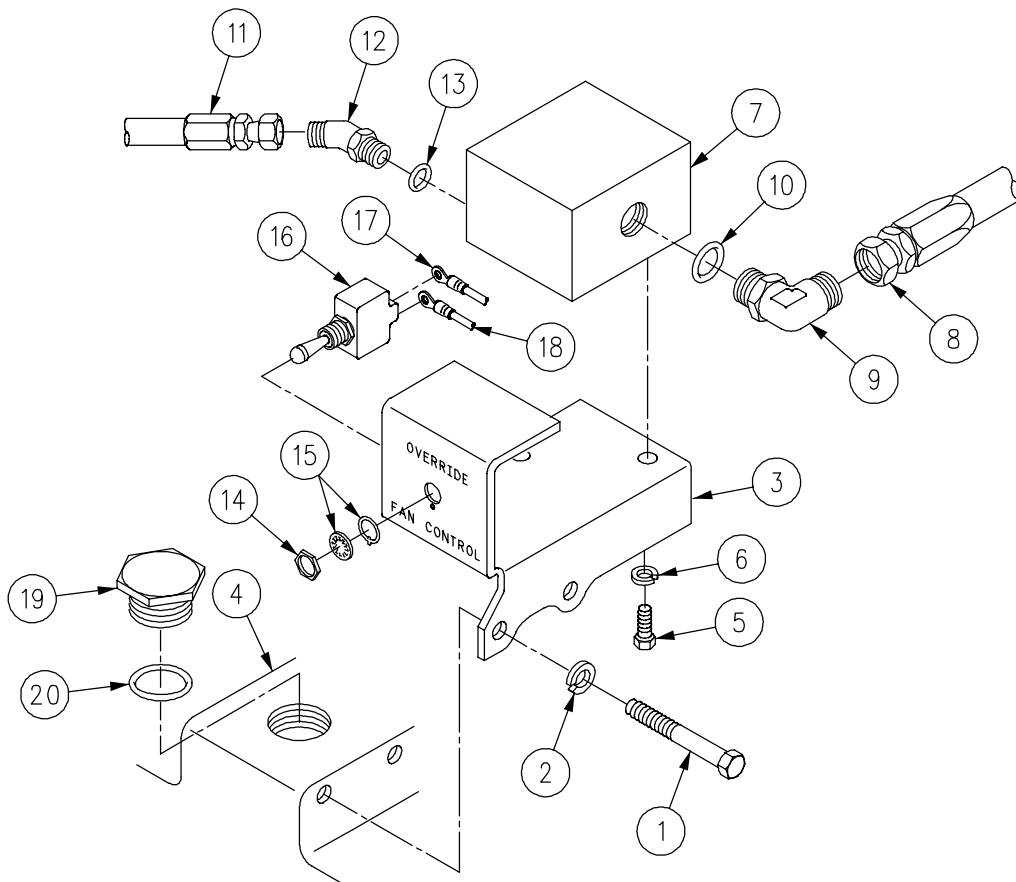

REPLACE VARIABLE SPEED FAN DRIVE VALVE AND OVERRIDE SWITCH (NEW CONFIGURATION) - Continued

0231 01

FOLLOW-THROUGH STEPS

1. Connect battery ground strap (WP 0337 00 or WP 0338 00).
2. Install driver's power plant access panel (see your-10).
3. Install power plant rear access panels (see your -10).

END OF TASK

REPLACE UPPER COOLANT HOSE AND TUBE

0232 00

THIS WORK PACKAGE COVERS:

Removal (page 0232 00-2).
 Installation (page 0232 00-4).

INITIAL SETUP:

Maintenance Level

Unit

References

See your -10

Tools and Special Tools

General Mechanic's Tool Kit (WP 0926 00, Item 65)

Equipment Condition

Engine stopped (see your -10)
 Carrier blocked (see your -10)
 Driver's power plant access panel
 removed (see your -10)
 Power plant upper rear access panel
 removed (see your -10)
 Cooling system drained (WP 0227 00)

Materials/Parts

Sealing compound (WP 0928 00, Item 56)
 Gasket
 Key washer (2)

Personnel Required

Unit Mechanic

REMOVAL

1. Loosen four clamps (1) on two hoses (2). Remove radiator inlet tube (3), hoses, and clamps.
2. Remove two screws (4), key washers (5), radiator inlet elbow (6), and gasket (7) from radiator (8). Discard gasket and key washers.

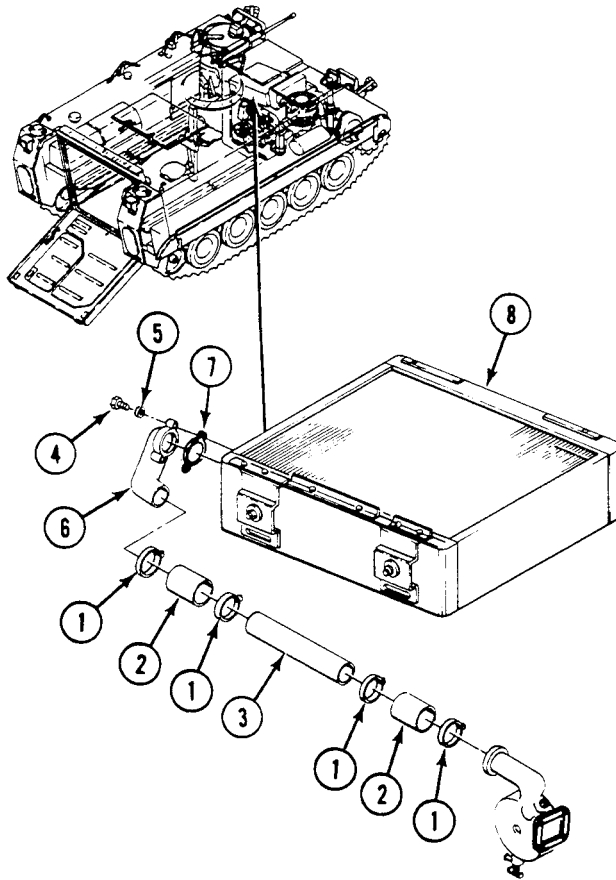

REPLACE UPPER COOLANT HOSE AND TUBE — Continued

0232 00

3. Loosen two clamps (1) and (2) on auxiliary tank outlet hose (3). Remove hose and clamps from auxiliary tank (4) and radiator outlet tube (5).
4. Loosen four clamps (6) and (7) on two vent hoses (8) and (9). Remove hoses and clamps.

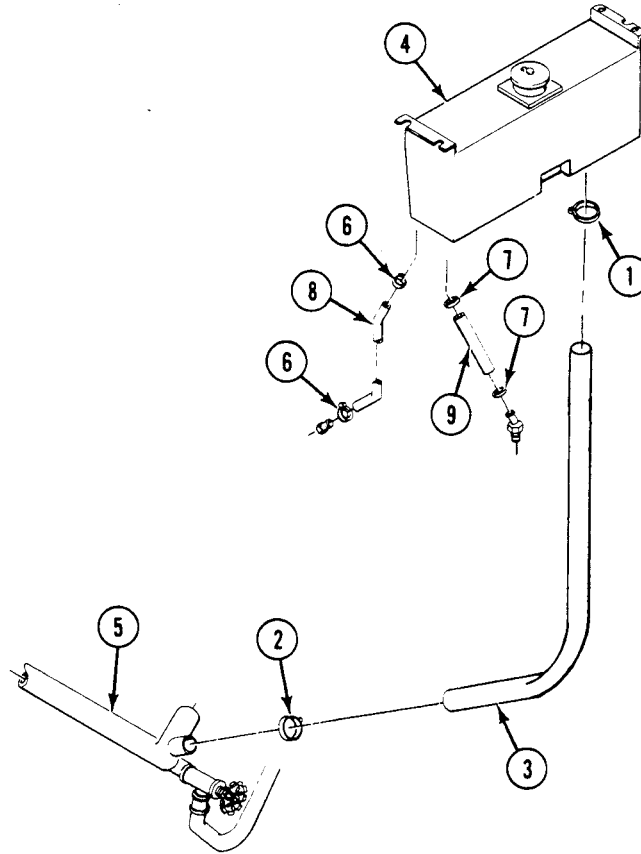

INSTALLATION

1. Install vent hose (10) on auxiliary tank (11) and air separator (12). Secure with two clamps (13).
2. Install vent hose (14) on auxiliary tank (11) and thermostat housing (15). Secure with two clamps (16).
3. Install hose (17) on auxiliary tank (11). Secure with clamp (18).

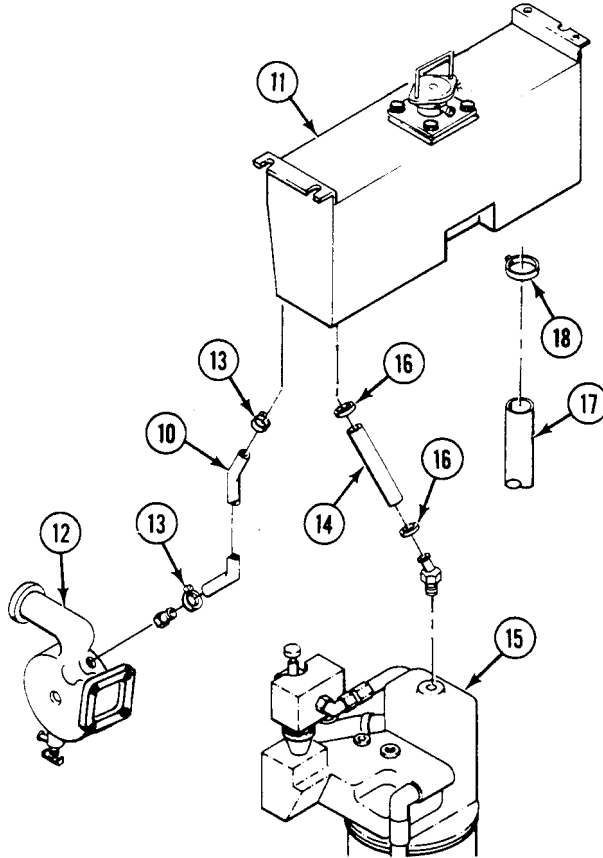

4. Install hose (19) on radiator outlet tube (20). Secure with clamp (21).

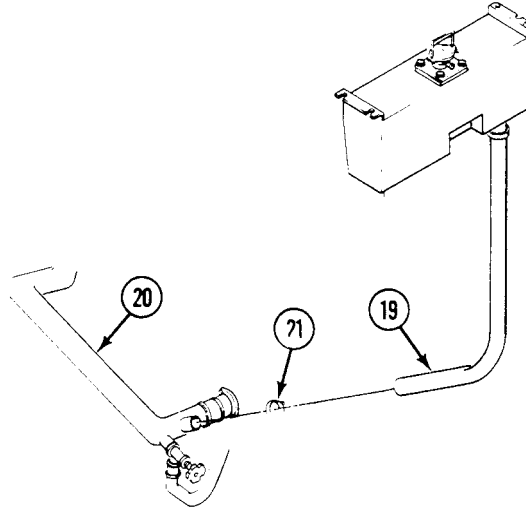

5. Apply a thin coat of sealing compound to both sides of new gasket (1) and tube elbow (2).
6. Install new gasket (1) on radiator inlet elbow (2). Secure elbow to radiator (3) with two screws (4) and new key washers (5).
7. Install two hoses (6) on radiator inlet tube (7). Secure hoses to tube, radiator inlet elbow (2), and air separator (8) with four clamps (9).

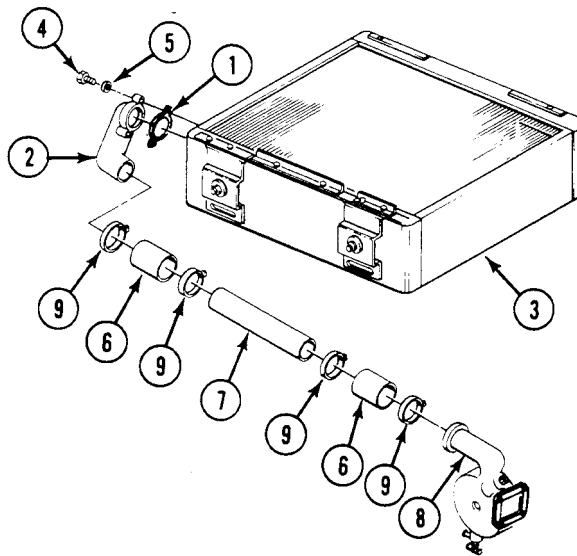

FOLLOW-THROUGH STEPS

1. Fill cooling system (WP 0227 00).
2. Install power plant upper rear access panel (see your -10).
3. Install driver's power plant access panel (see your -10).

END OF TASK

REPLACE RADIATOR OUTLET TUBE AND HOSES

0233 00

THIS WORK PACKAGE COVERS:

Removal (page 0233 00-1).
 Installation (page 0233 00-2).

INITIAL SETUP:

Maintenance Level

Unit

References

See your -10

Tools and Special Tools

General Mechanic's Tool Kit (WP 0926 00, Item 65)

Equipment Condition

Engine stopped (see your -10)
 Carrier blocked (see your -10)
 Master switch OFF (see your -10)
 Driver's power plant access panel removed (see your -10)
 Power plant rear access panels removed (see your -10)
 Power plant removed (WP 0156 00)

Materials/Parts

Sealing compound (WP 0928 00, Item 56)
 Gasket
 Gasket
 Key washer (2)
 Lockwasher (2)

Personnel Required

Unit Mechanic

REMOVAL

1. Loosen clamp (1) securing drain hose (2) to drain cock (3). Remove hose and clamp.
2. Remove drain cock (3) from elbow (4). Remove elbow (4) from radiator outlet tube (5).
3. Loosen clamp (6) securing auxiliary tank outlet hose (7) to radiator outlet tube (5). Remove clamp and hose.
4. Remove two clamps (8) securing radiator outlet tube (5) to tube support bracket (9).
5. Loosen four clamps (10) securing two hoses (11) and radiator outlet tube (5) to adapter (12) and tube (13). Remove clamps, hoses, and tube.
6. Loosen two clamps (14) securing tube (13) and hose (15) to radiator outlet elbow. Remove clamps, hose, and tube.

- Remove two screws (16), lockwashers (17), washers (18), adapter (12), and gasket (19) from engine. Discard gasket and lockwashers.

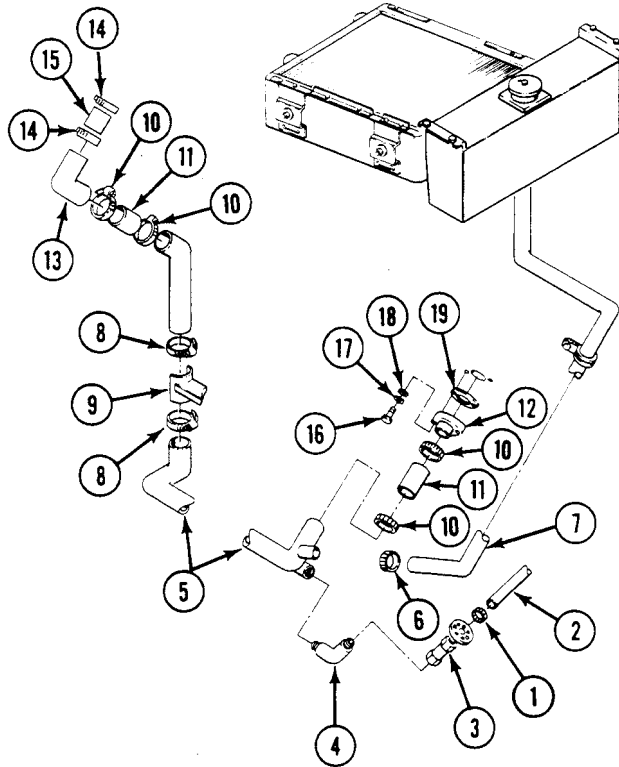

- Remove two screws (1), key washers (2), radiator outlet elbow (3), and gasket (4) from radiator (5). Discard gasket and key washers.

INSTALLATION

- Apply sealing compound to mounting surfaces of new gasket (4).
- Install radiator outlet elbow (3) with new gasket (4) on radiator (5). Secure with two screws (1) and new key washers (2).

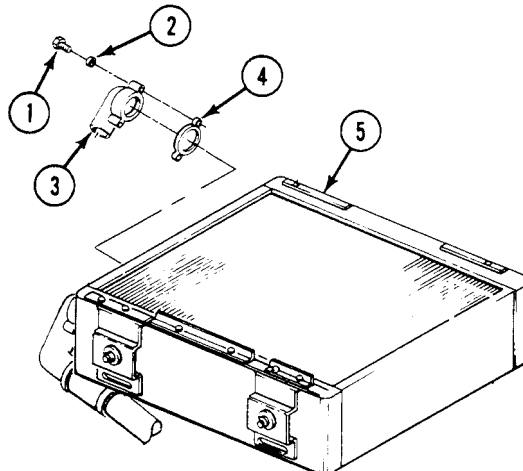

REPLACE RADIATOR OUTLET TUBE AND HOSES — Continued**0233 00**

3. Apply sealing compound to mounting surfaces of new gasket (6).
4. Install adapter (7) with new gasket (6) on engine. Secure with two screws (8), washers (9), and new lockwashers (10).
5. Install hose (11) and tube (12) on radiator outlet elbow (3). Secure with two clamps (13).
6. Install radiator outlet tube (14) and two hoses (15) on tube (12) and adapter (7). Secure with four clamps (16).
7. Secure radiator outlet tube (14) to support bracket (17) with two clamps (18).
8. Install auxiliary tank outlet hose (19) on radiator outlet tube (14). Secure with clamp (20).
9. Install elbow (21) on radiator outlet tube (14). Install drain cock (22) on elbow (21).
10. Install drain hose (23) on drain cock (22). Secure with clamp (24).

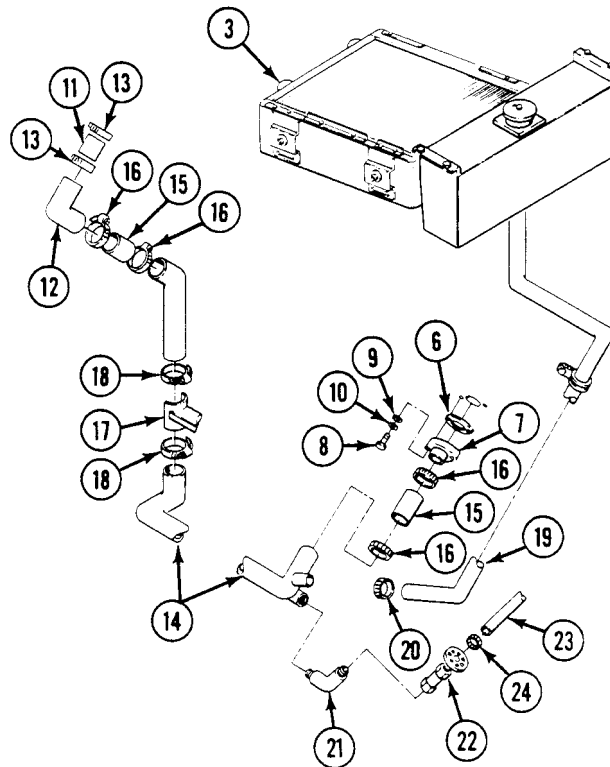
**FOLLOW-THROUGH STEPS**

1. Install power plant (WP 0156 00).
2. Install power plant rear access panels (see your -10).
3. Install driver's power plant access panel (see your -10).

END OF TASK

REPLACE BALANCE HOSE

0234 00

THIS WORK PACKAGE COVERS:

- Removal (page 0234 00-1).
 - Installation (page 0234 00-1).
-

INITIAL SETUP:

Maintenance Level

Unit

Equipment Condition

- Engine stopped (see your -10)
- Carrier blocked (see your -10)
- Power plant grill raised (WP 0464 00)
- Grill air intake elbow and hose removed (WP 0174 00)

Tools and Special Tools

General Mechanic's Tool Kit (WP 0926 00, Item 65)

Personnel Required

Unit Mechanic

References

See your -10

REMOVAL

1. Loosen two clamps (1) on balance hose (2). Remove hose and clamps.

INSTALLATION

1. Slide two clamps (1) on balance hose (2).
2. Install balance hose (2) on auxiliary tank (3) and radiator (4). Tighten two clamps (1).

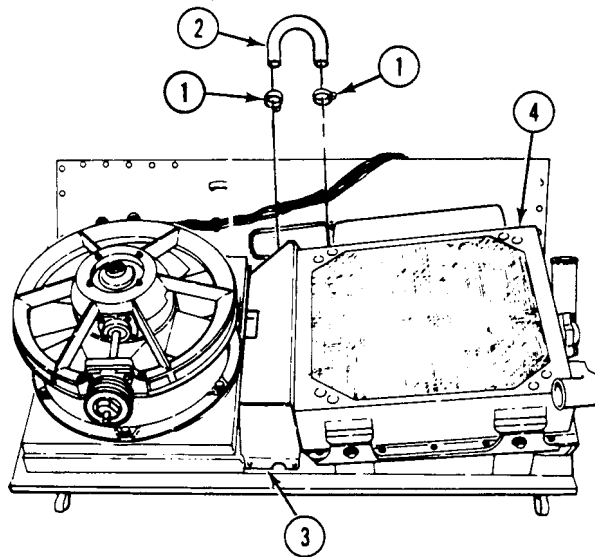

FOLLOW-THROUGH STEPS

1. Install grill air intake elbow and hose (WP 0174 00).
2. Lower power plant grill (WP 0464 00).

END OF TASK

REPLACE DRAIN COCK AND HOSE

0235 00

THIS WORK PACKAGE COVERS:

Removal (page 0235 00-1).
 Installation (page 0235 00-1).

INITIAL SETUP:

Maintenance Level

Unit

References

See your -10

Tools and Special Tools

General Mechanic's Tool Kit (WP 0926 00, Item 65)

Equipment Condition

Engine stopped (see your -10)

Materials/Parts

Sealing compound (WP 0928 00, Item 56)

Carrier blocked (see your -10)

Power plant lower rear access panel removed (see your -10)

Personnel Required

Unit Mechanic

Power plant bottom access cover removed (WP 0450 00)

Cooling system drained (WP 0227 00)

REMOVAL

1. Loosen clamp (1) on drain hose (2). Remove hose (2) from drain cock (3).
2. Remove cock (3) from radiator outlet tube (4).

INSTALLATION

1. Apply light coat of sealing compound to external tapered threads of cock (3).
2. Install cock (3) on radiator outlet tube (4).
3. Install hose (2) on cock (3). Secure with clamp (1).

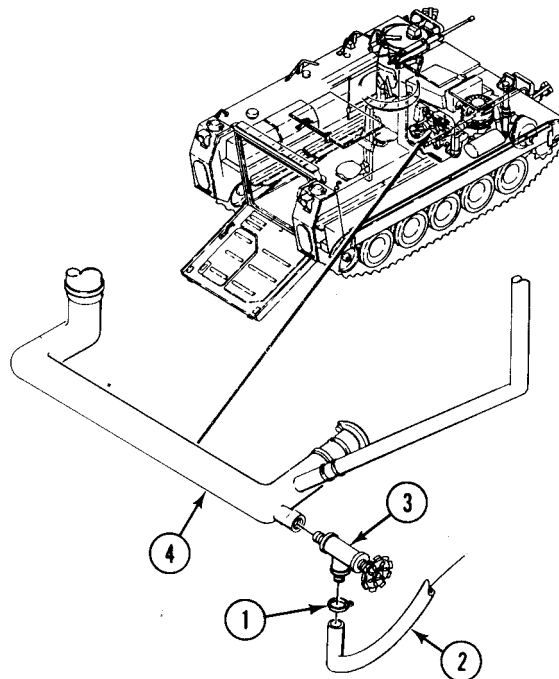

FOLLOW-THROUGH STEPS

1. Fill cooling system (WP 0227 00).
2. Install power plant bottom access cover (WP 0450 00).
3. Install power plant lower rear access panel (see your -10).

END OF TASK

REPLACE COOLANT AIR SEPARATOR

0236 00

THIS WORK PACKAGE COVERS:

Removal (page 0236 00-1).
 Installation (page 0236 00-3).

INITIAL SETUP:

Maintenance Level

Unit

References

See your -10

Tools and Special Tools

General Mechanic's Tool Kit (WP 0926 00, Item 65)

Equipment Condition

Materials/Parts

Sealing compound (WP 0928 00, Item 56)

Gasket

Key washer (4)

Engine stopped (see your -10)

Carrier blocked (see your -10)

Power plant rear upper access panel
 removed (see your -10)

Personnel Required

Unit Mechanic

Cooling system drained (WP 0227 00)

REMOVAL

1. Loosen two clamps (1) on hose (2). Remove hose from air separator (3).
2. Loosen clamp (4) on vent hose (5). Remove hose from air separator (3).

3. Remove drain cock (6) from air separator (3).

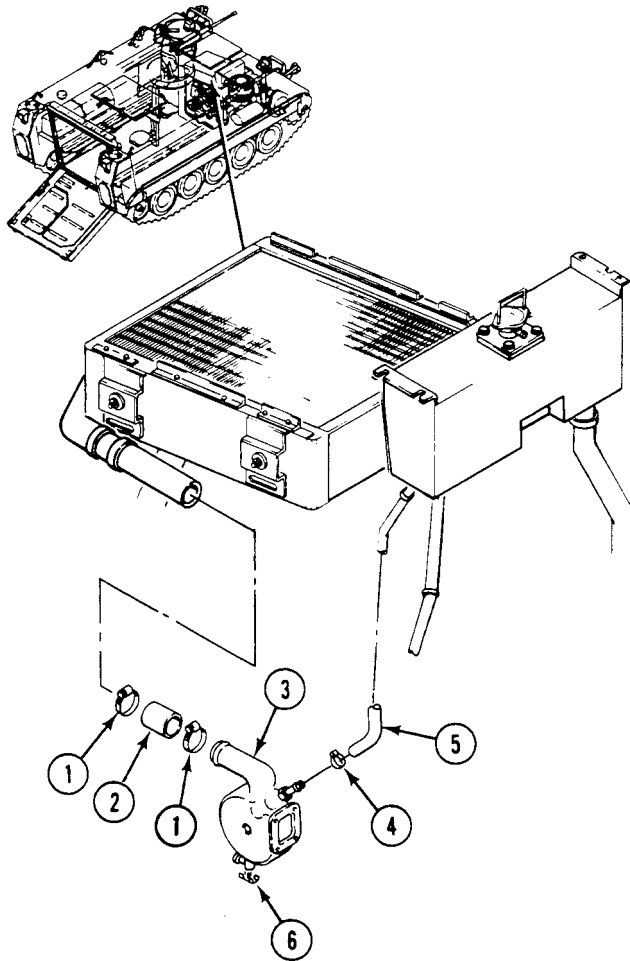

4. Remove four screws (1), key washers (2), air separator (3), and gasket (4) from thermostat housing (5). Discard gasket and key washers.

5. Remove adapter (6) from air separator (3).

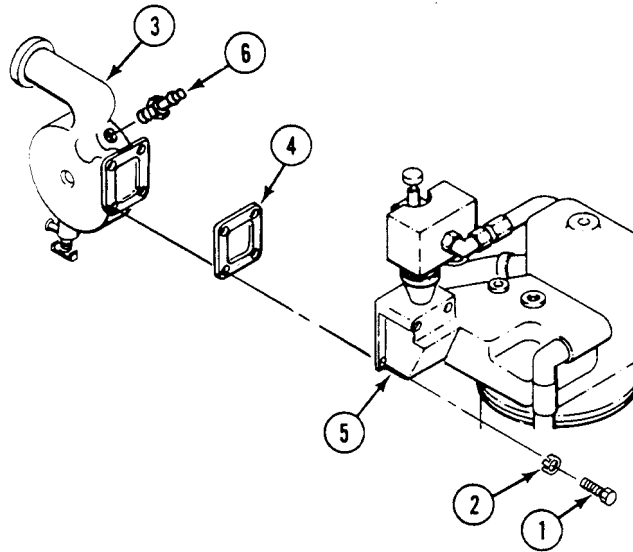

INSTALLATION

1. Install adapter (6) on air separator (3).
2. Install air separator (3) and new gasket (4) on thermostat housing (5). Secure with four screws (1) and new key washers (2).

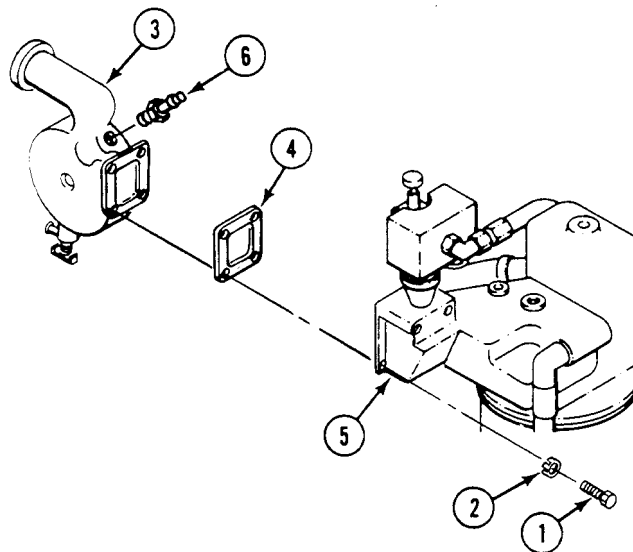

REPLACE COOLANT AIR SEPARATOR — Continued

0236 00

3. Install drain cock (7) on air separator (3).
4. Install vent hose (8) on adapter (6). Tighten clamp (9).
5. Install hose (10) on air separator (3). Tighten two clamps (11).

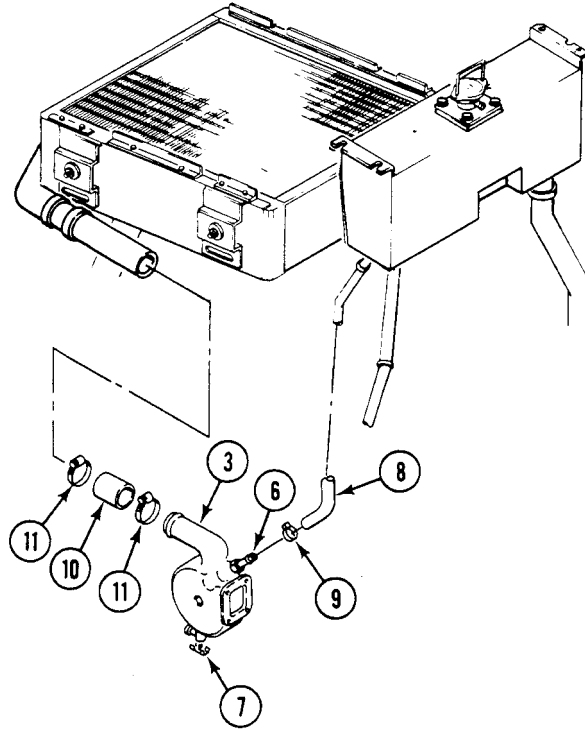
**FOLLOW-THROUGH STEPS**

1. Fill cooling system (WP 0227 00).
2. Install power plant rear upper access panel (see your -10).

END OF TASK

REPLACE THERMOSTAT/COVER

0237 00

THIS WORK PACKAGE COVERS:

Removal (page 0237 00-1).
 Installation (page 0237 00-4).

INITIAL SETUP:

Maintenance Level

Unit

References

See your -10

Tools and Special Tools

General Mechanic's Tool Kit (WP 0926 00, Item 65)

Equipment Condition

Materials/Parts

Adhesive (WP 0928 00, Item 4)

Gasket

Lockwasher (4)

Engine stopped (see your -10)

Carrier blocked (see your -10)

Cooling system drained (WP 0227 00)

Power plant upper rear access panel

removed (see your -10)

Personnel Required

Unit Mechanic

Coolant air separator removed (WP 0236 00)

REMOVAL

1. Remove oil supply hose (1) from elbow (2) on thermostat switch (3).
2. Remove two hoses (4) and (5) from adapters (6) and (7).

3. Loosen two clamps (8) and slide hose (9) down on bypass tube (10).

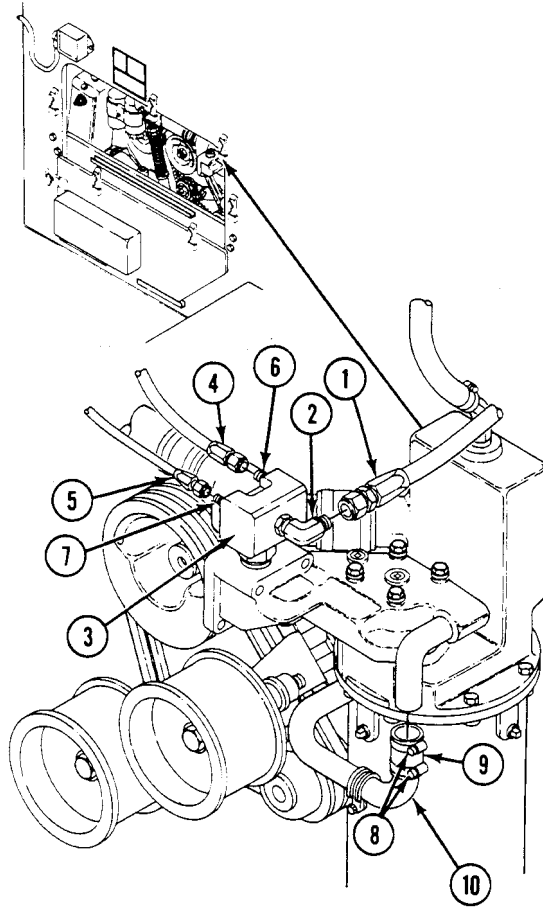

4. Remove four screws (1), lockwashers (2), washers (3), thermostat cover (4), and gasket (5) from thermostat housing (6). Discard lockwashers and gasket.

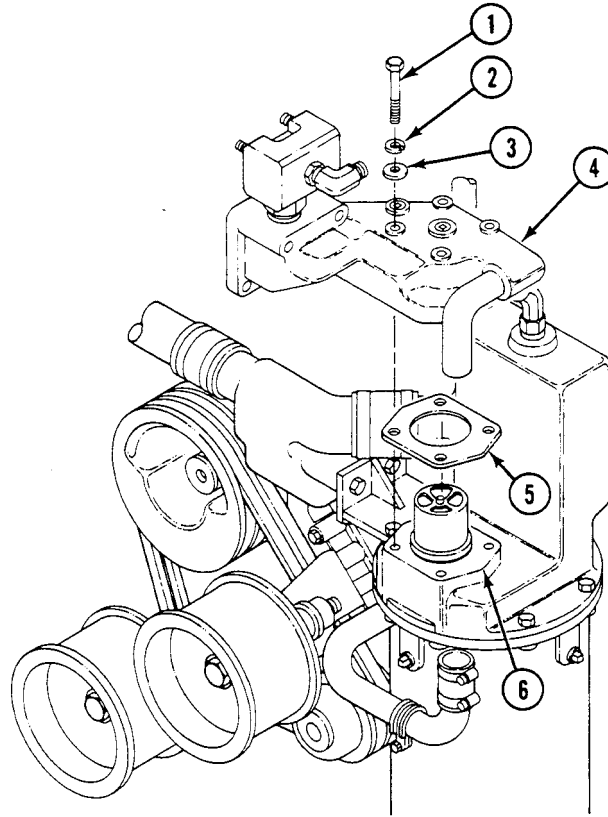

5. Remove thermostat (7) from thermostat housing (6).

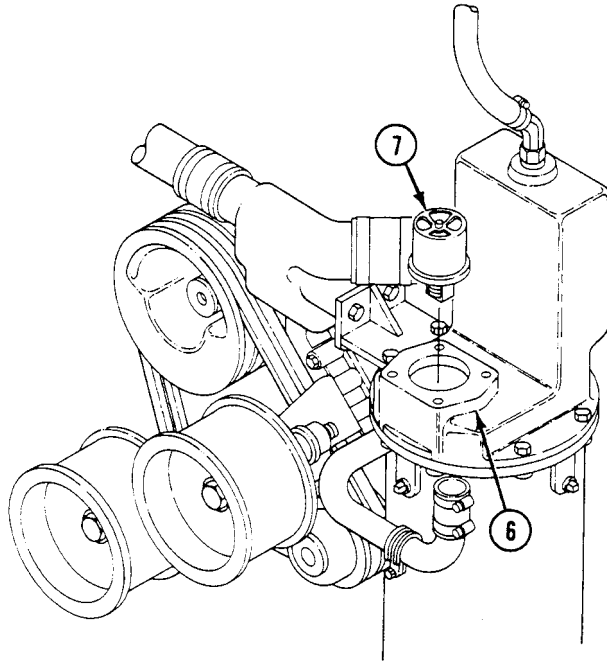

INSTALLATION

1. Install thermostat (7) on thermostat housing (6).

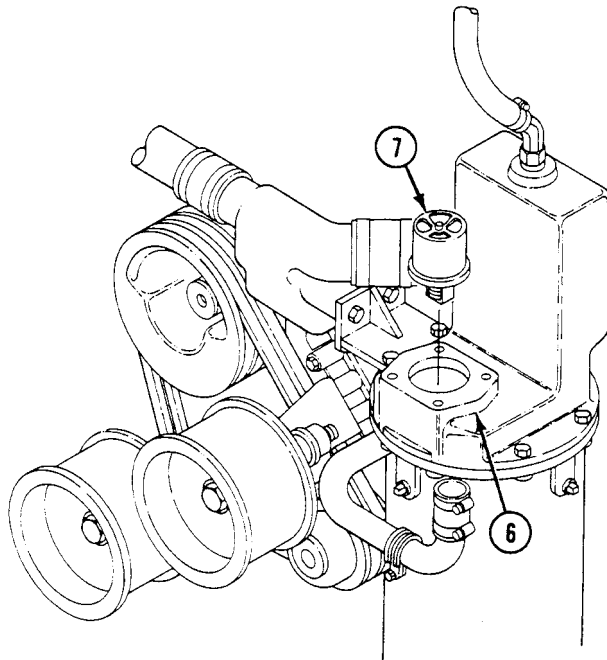

2. Apply a thin coat of adhesive to both sides of new gasket (8).
3. Install gasket (8), thermostat cover (9), four washers (10), new lockwashers (11), and screws (12) on thermostat housing (6).

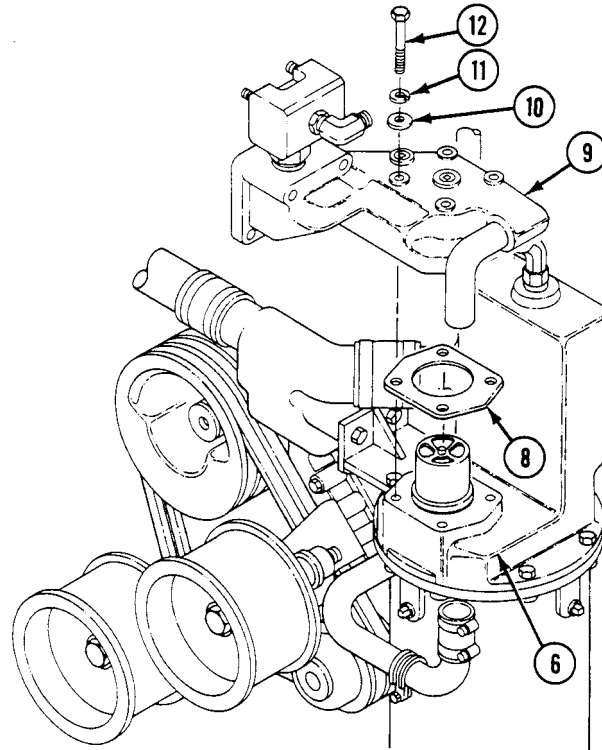

REPLACE THERMOSTAT/COVER — Continued

0237 00

4. Install hose (1) on thermostat cover (2) and bypass tube (3). Secure with two clamps (4).
5. Install two hoses (5) and (6) on adapters (7) and (8).
6. Install oil supply hose (9) on elbow (10) on thermostat switch (11).

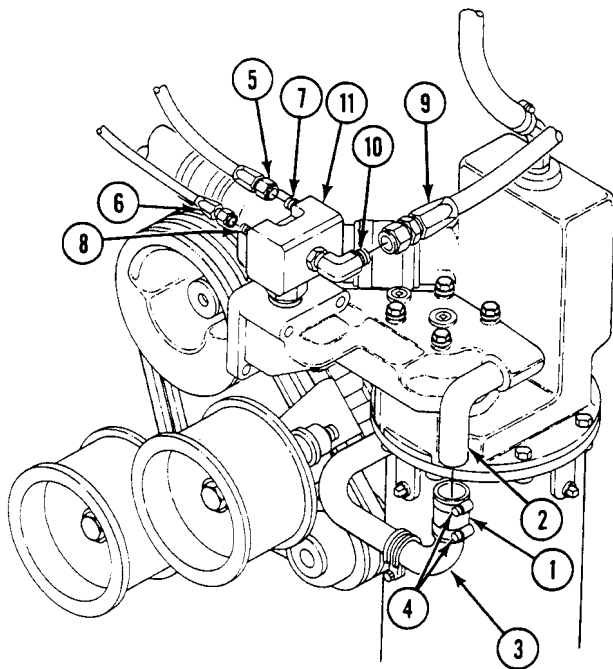
**FOLLOW-THROUGH STEPS**

1. Install coolant air separator (WP 0236 00).
2. Fill cooling system (WP 0227 00).
3. Install power plant upper rear access panel (see your -10).

END OF TASK

REPLACE THERMOSTAT TUBE/HOSES

0238 00

THIS WORK PACKAGE COVERS:

Removal (page 0238 00-1).
 Installation (page 0238 00-2).

INITIAL SETUP:

Maintenance Level

Unit

Equipment Condition

Engine stopped (see your -10)
 Carrier blocked (see your -10)
 Power plant upper and lower rear access panels and support removed (see your -10)

Tools and Special Tools

General Mechanic's Tool Kit (WP 0926 00, Item 65)

Personnel Required

Unit Mechanic

References

See your -10

REMOVAL

1. Loosen two upper clamps (1) and slide hose (2) down on bypass tube (3).
2. Disconnect two hose clamps (4) that support coolant hose (5).

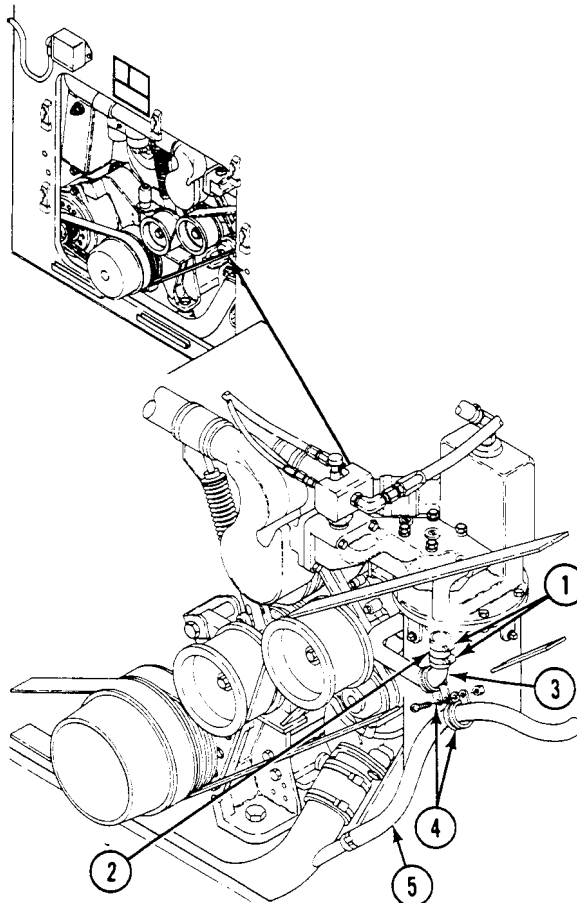

3. Loosen two lower hose clamps (6) on water pump housing (7) and slide hose (8) up on tube (3).
4. Remove tube (3), hoses (2) and (8) and clamps (1) and (6) as a unit.
5. Remove four clamps (1) and (6) and two hoses (2) and (8) from tube (3).
6. Inspect two hoses (2) and (8) for cracks or deterioration. Replace if necessary.

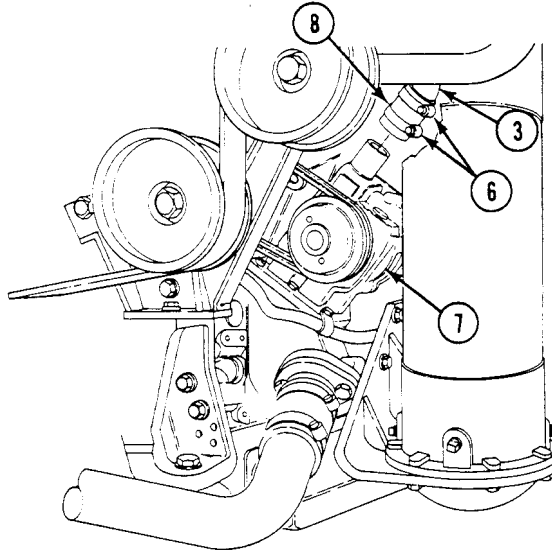

INSTALLATION

1. Install hose (1) and two clamps (2) on lower end of new tube (3).
2. Install hose (4) and two clamps (5) on upper end of tube (3).
3. Place tube (3) with two hoses (1) and (4) and four clamps (2) and (5) in position on engine. Slide upper hose (4) onto thermostat housing (6) and tighten with two clamps (5).

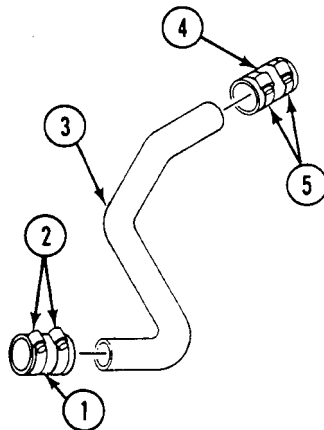

4. Connect the two hose clamps (7) that support the coolant hose (8).

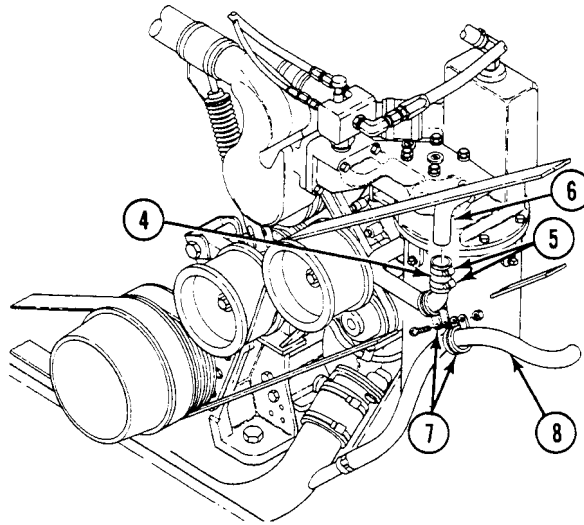

5. Slide lower hose (1) onto water pump housing (9). Position two clamps (2) and tighten.

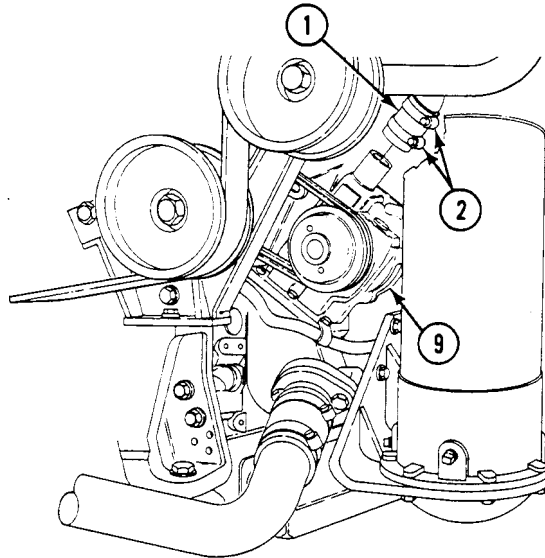

FOLLOW-THROUGH STEPS

1. Install power plant upper and lower rear access panels and support (see your -10).

END OF TASK

ADJUST COOLANT PUMP BELTS

0239 00

THIS WORK PACKAGE COVERS:

Adjust (page 0239 00-1).

INITIAL SETUP:

Maintenance Level

Unit

References

See your -10

Tools and Special Tools

General Mechanic's Tool Kit (WP 0926 00, Item 65)
 Torque Wrench (WP 0926 00, Item 81)
 Socket Set (WP 0926 00, Item 72)

Equipment Condition

Engine stopped (see your -10)
 Carrier blocked (see your -10)
 Power plant rear access panels removed (see your -10)

Personnel Required

Unit Mechanic

ADJUSTMENT

NOTE

Idler arm, pulleys, and belts are removed from art for clarity only. Physical removal of these items is not required to access coolant pump belts for adjustment.

1. Loosen two screws (2) securing idler adjusting bracket (1) to engine.

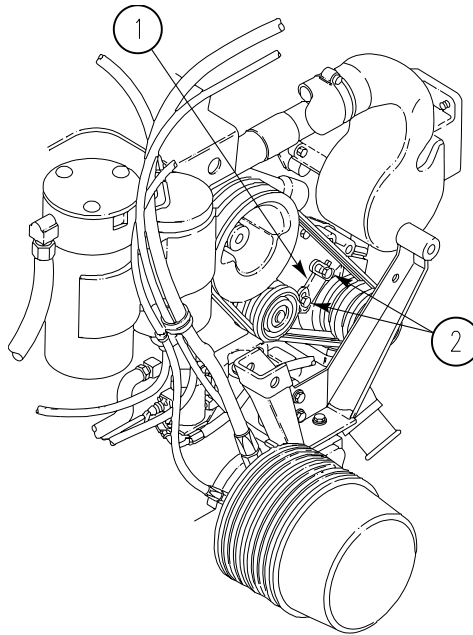

ADJUST COOLANT PUMP BELTS — Continued**0239 00**

2. Pry upward on tang of idler pulley assembly (5) to get 1/4 to 3/8 inch deflection on drive belts (6) midway between pulleys (1) and (3) while applying a firm push with thumb. Tighten two screws (4).
3. Check for proper tension by using straight edge (2) to measure deflection across drive belts at pulleys (1) and (3). If tension meter is available, check 40-50 lbs (173–217 N) tension. If necessary, readjust tension, and then torque two screws (4) to 360-420 lb-in (41-47 N.m).

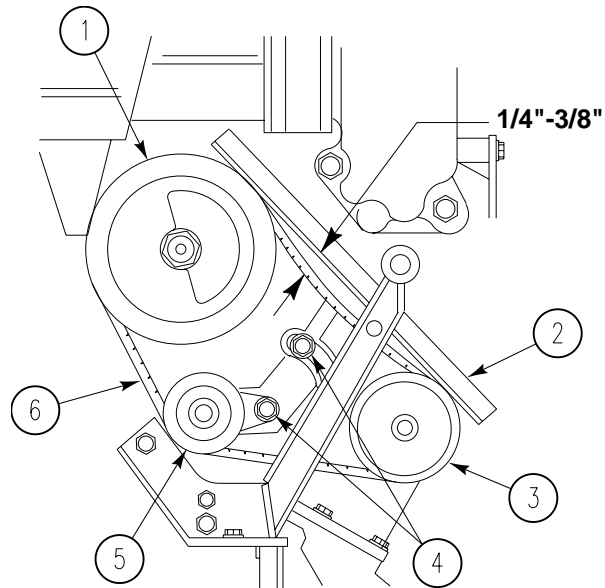
**FOLLOW-THROUGH STEPS**

1. Install power plant rear access panels (see your -10).

END OF TASK

REPLACE COOLANT PUMP IDLER PULLEY/BELTS

0240 00

THIS WORK PACKAGE COVERS:

Removal (page 0240 00-1).
 Installation (page 0240 00-2).

INITIAL SETUP:

Maintenance Level

Unit

References

See your -10

Tools and Special Tools

General Mechanic's Tool Kit (WP 0926 00, Item 65)
 Torque Wrench (WP 0926 00, Item 81)
 Socket Set (WP 0926 00, Item 72)

Equipment Condition

Engine stopped (see your -10)

Carrier blocked (see your -10)

Materials/Parts

Lockwasher (2)

Personnel Required

Unit Mechanic

Power plant rear access panels removed (see your -10)

REMOVAL

NOTE

Idler arm, pulleys, and belts are removed from art for clarity only. Physical removal of these items is not required to access coolant pump belts for adjustment.

1. Loosen two screws (4) securing idler adjusting bracket (2) to engine.
2. Remove two drive belts (5) from three pulleys (1)(6)(7).
3. If damaged, remove two screws (4), washers (3), idler adjusting bracket (2) and idler pulley (7) from engine.

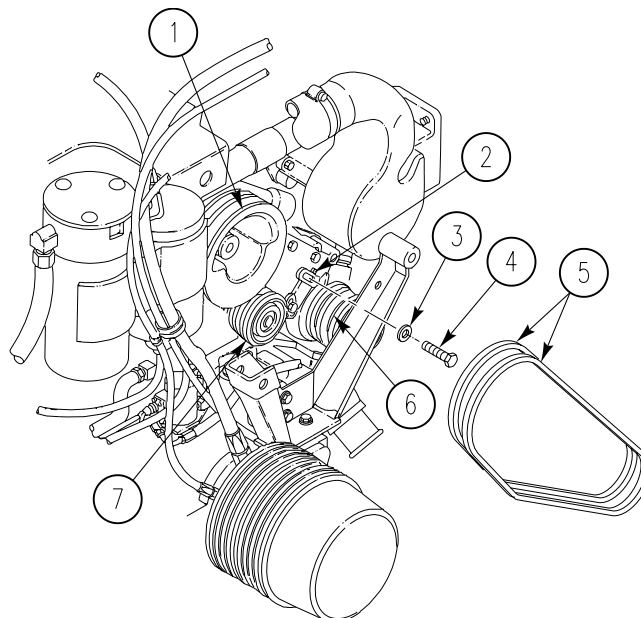

INSTALLATION

1. If removed, install idler pulley (7) and idler adjusting bracket (2) on engine. Secure with two washers (3) and screws (4). Do not tighten screws.

NOTE

Drive belts must be replaced in matched sets.

2. Position two drive belts (5) on three pulleys (1)(6)(7).
3. Pry upward on tang of idler pulley assembly (2) to get 1/4 to 3/8 inch deflection on drive belts (5) midway between pulleys (1) and (6) while applying a firm push with thumb. Tighten two screws (4).

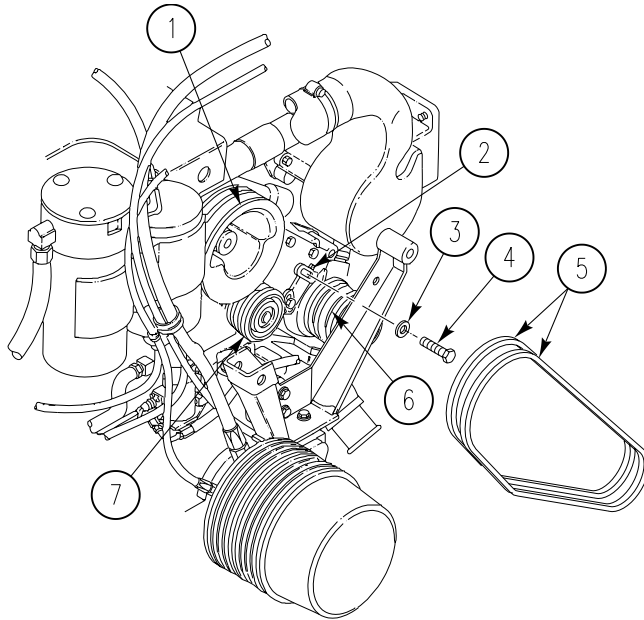

4. Check for proper tension by using straight edge (2) to measure deflection across drive belts at pulleys (1) and (3). If tension meter is available, check 40-50 lbs (173-217 N) tension. If necessary, readjust tension, and then torque two screws (4) to 360-420 lb-in (41-47 N.m).

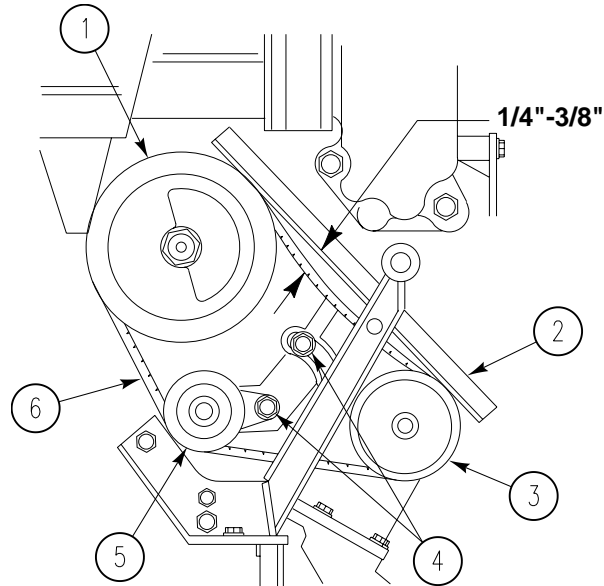
**FOLLOW-THROUGH STEPS**

1. Install power plant rear access panels (see your -10).

END OF TASK

REPLACE ENGINE COOLANT PUMP

0241 00

THIS WORK PACKAGE COVERS:

- Removal (page 0241 00-1).
- Installation (page 0241 00-4).

INITIAL SETUP:

Maintenance Level
Unit

Personnel Required
Unit Mechanic

Tools and Special Tools
General Mechanic's Tool Kit (WP 0926 00, Item 65)

References
See your -10

Materials/Parts
Cotter pin
Gasket
Locknut
Lockwasher
Lockwasher
Lockwasher (2)
Lockwasher (4)

Equipment Condition
Power plant removed from carrier (WP 0156 00)
Ventilating fan drive belt removed (WP 0243 00)

REMOVAL

1. Remove cotter pin (1), pin (2) and spring tensioner (3) from bracket (4). Discard cotter pin.

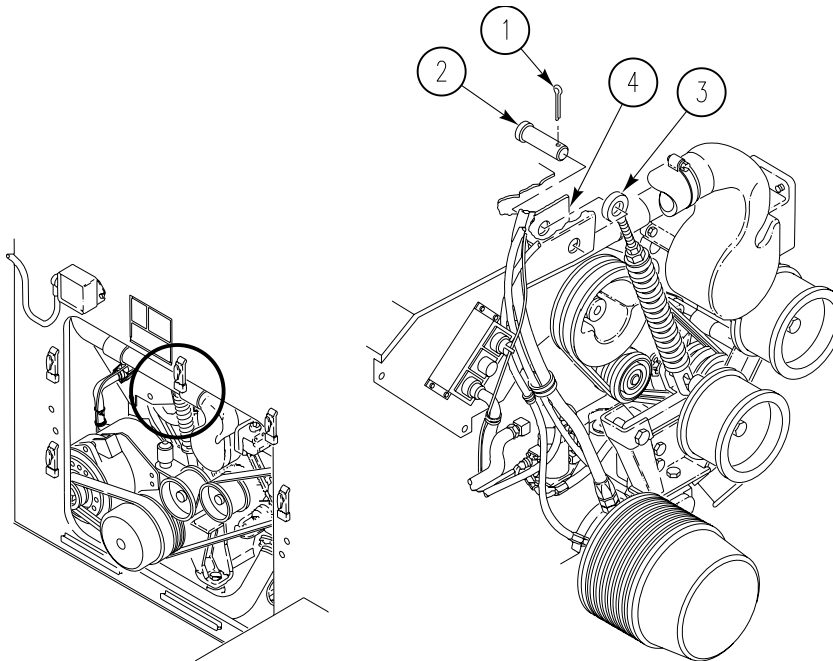

2. Remove locknut (5), two washers (3)(6), screw (1), and pulley (2) from bracket (4). Discard locknut.

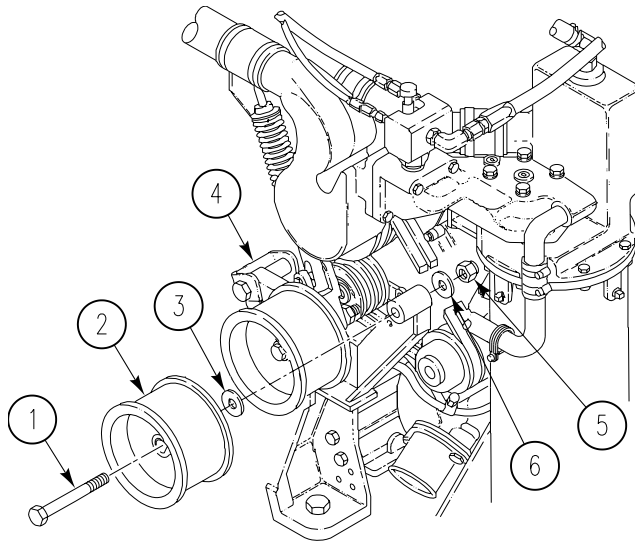

3. Remove screw (1), lockwasher (2), washer (3), and two spacers (5) from bracket (4). Discard lockwasher.

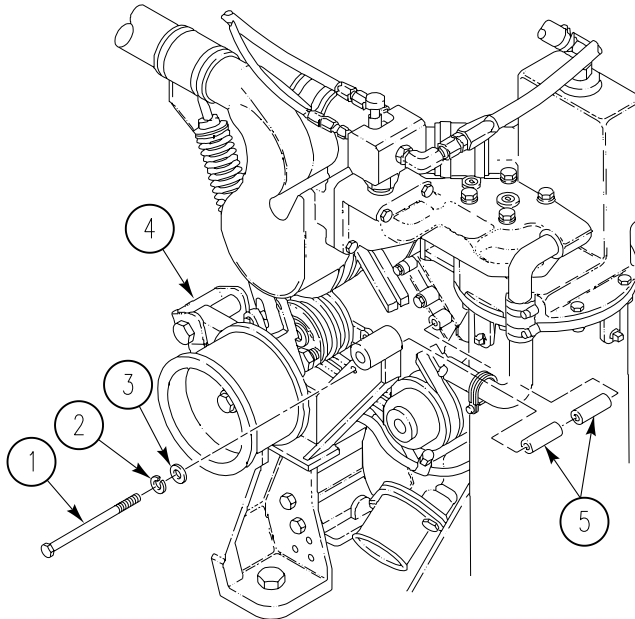

4. Remove screw (2), washer (3), locknut (4), and idler arm bracket (1) from engine. Discard locknut.

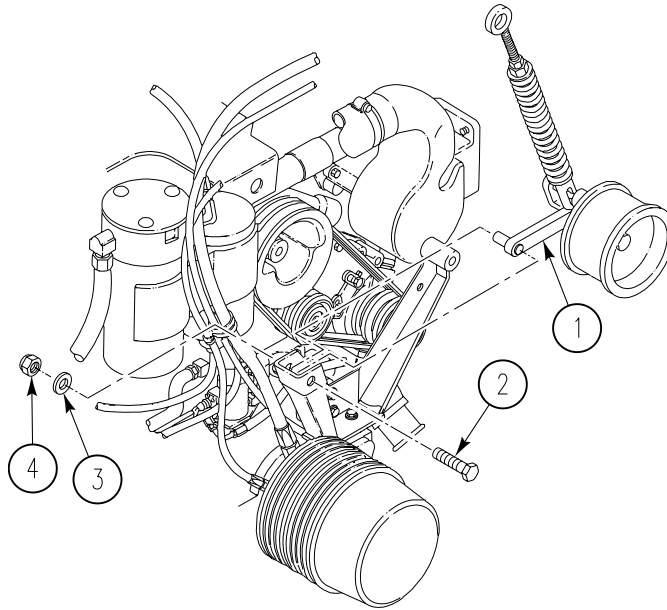

5. Loosen two screws (5) securing idler adjusting bracket (2) to engine.
6. Remove two drive belts (4) from three pulleys (1)(3)(6).

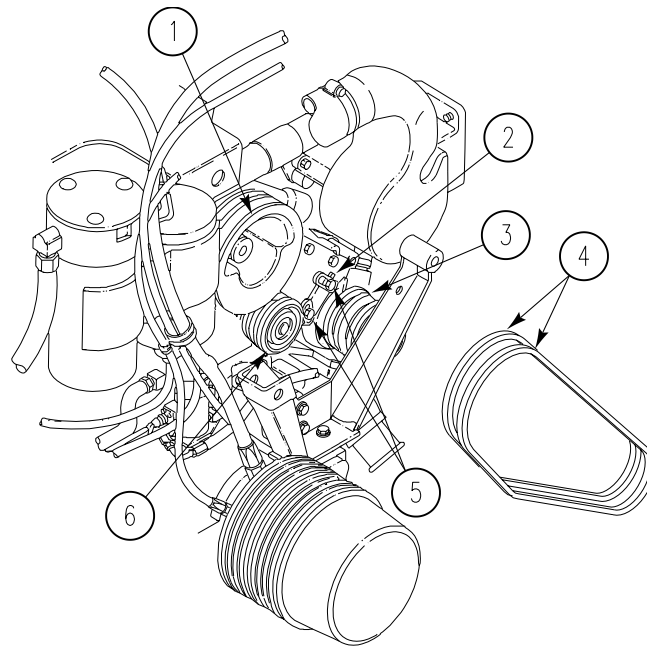

- Remove two screws (4), washers (3), idler adjusting bracket (2) and idler pulley (7) from engine.

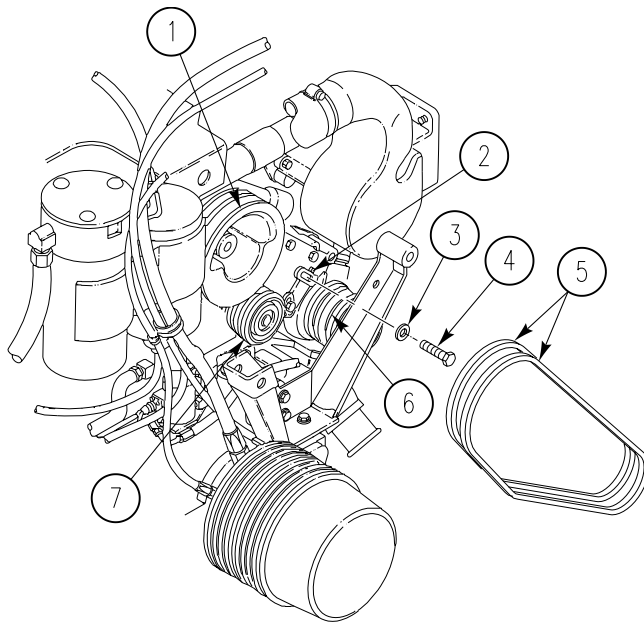

- Loosen two clamps (5) and slide bypass hose (6) up on thermostat tube (7).
- Remove four cap screws (8), lockwashers (9), washers (10), one socket head screw (11), hose bracket (12), coolant pump (13), and gasket (14) from oil cooler housing. Discard lockwashers and gasket.

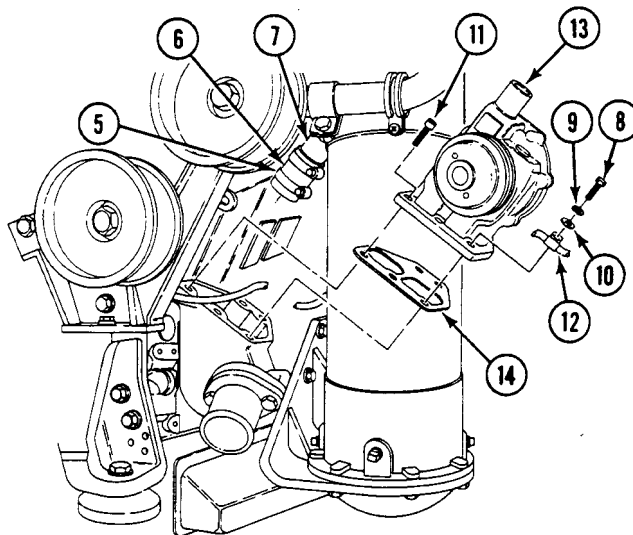

INSTALLATION

- Secure new gasket (14), coolant pump (13), and hose bracket (12) to oil cooler housing with one socket head screw (11), four washers (10), new lockwashers (9) and cap screws (8).

- Secure bypass hose (6) to thermostat tube (7) and coolant pump (13) with two clamps (5).

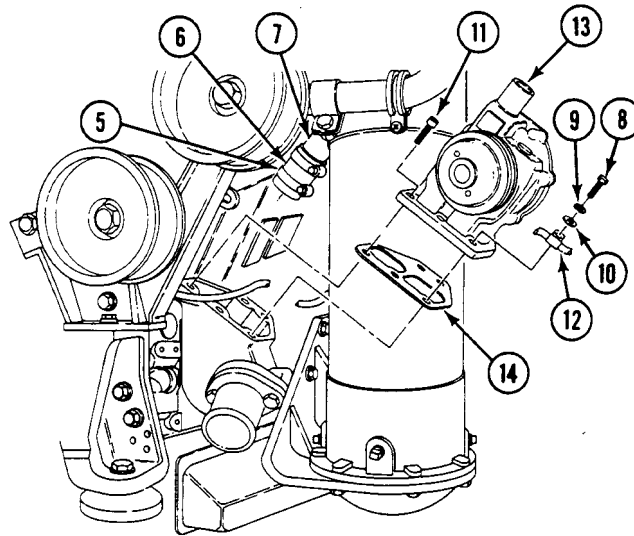

- Install idler pulley (7) and idler adjusting bracket (2) on engine. Secure with two washers (3) and screws (4). Do not tighten screws.

NOTE

Drive belts must be replaced in matched sets.

- Position two drive belts (5) on three pulleys (1)(6)(7).
- Move idler adjusting bracket (2) to obtain a 3/8 inch (10mm) deflection when two drive belts (5) are depressed midway between pulleys (1) and (6).
- Tighten two screws (4) to 30-35 lb-ft (41-47 N.m) torque.

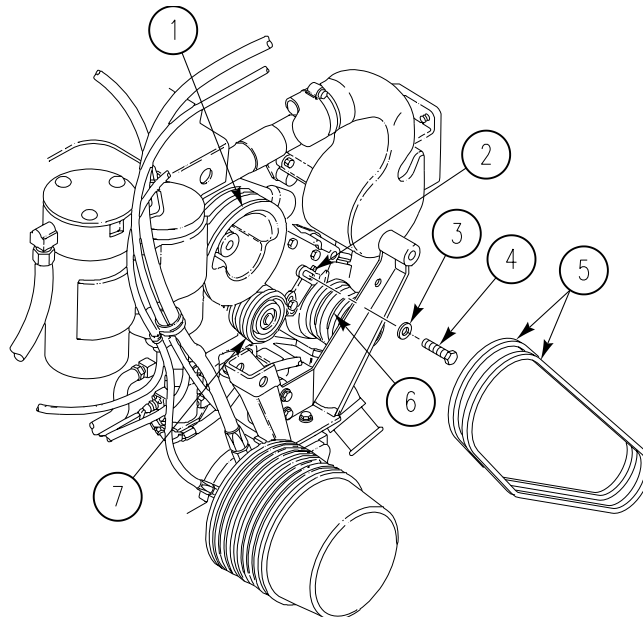

7. Install idler arm bracket (1) on engine. Secure with screw (2), washer (3), and new locknut (4).

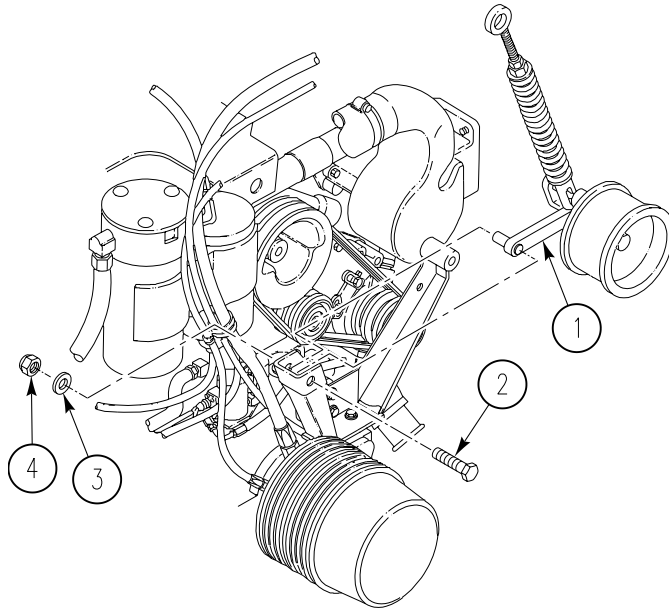

8. Install two screws (3), new lockwashers (2), and washers (1) on bracket (4).

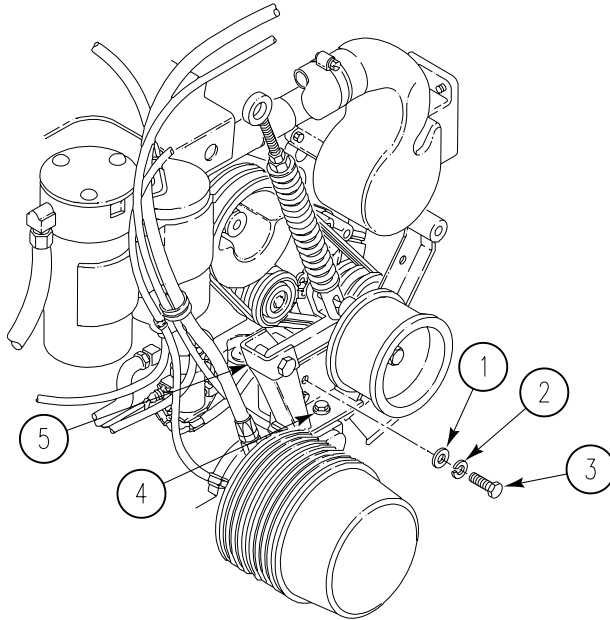

9. Install screw (1), new lockwasher (2), washer (3), and two spacers (5) on bracket (4).

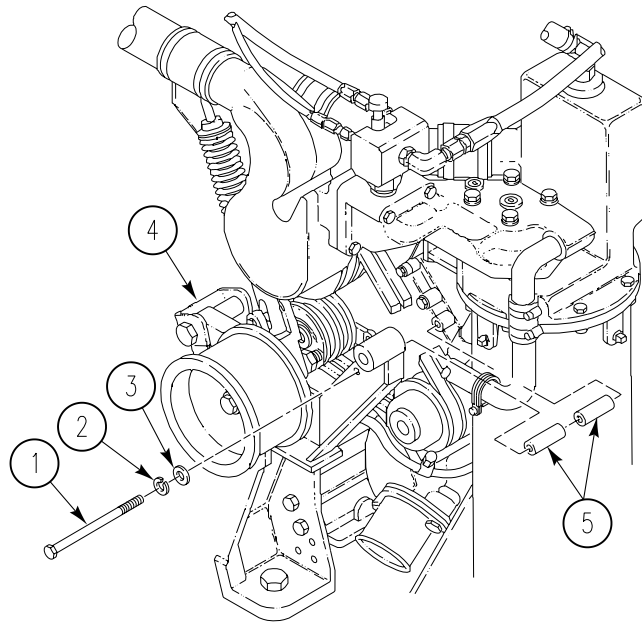

10. Install pulley (2), screw (1), two washers (3)(6), and new locknut (5) on bracket (4).

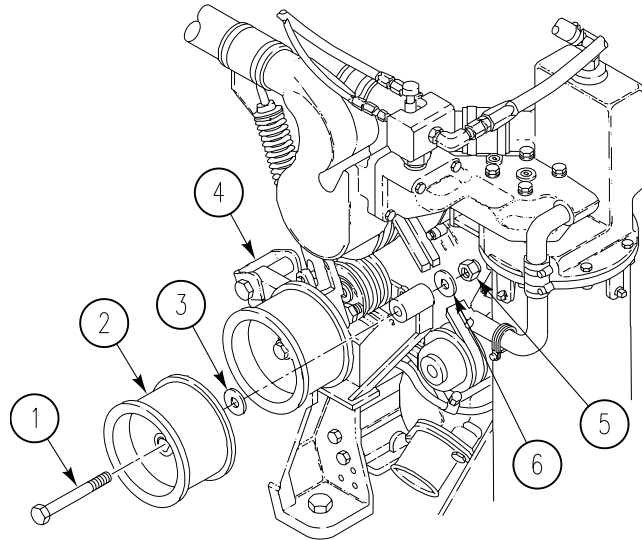

11. Install pin (2), spring tensioner (3), and new cotter pin (1) on bracket (4).

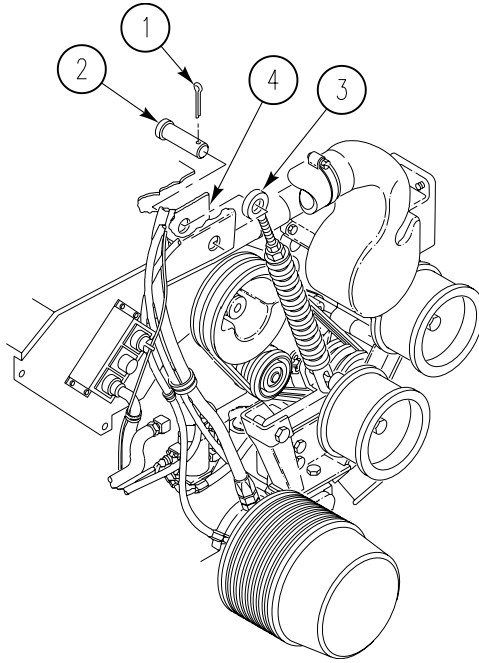
**FOLLOW-THROUGH STEPS**

1. Install ventilating fan drive belt (WP 0243 00).
2. Install power plant in carrier (WP 0156 00).

END OF TASK

ADJUST VENTILATING FAN DRIVE BELT

0242 00

THIS WORK PACKAGE COVERS:

Adjustment (page 0242 00-1).

INITIAL SETUP:

Maintenance Level

Unit

References

See your -10

Tools and Special Tools

- General Mechanic's Tool Kit (WP 0926 00, Item 65)
- V-Belt Tensiometer (WP 0926 00, Item 59)
- Adjustable Wrench (WP 0926 00, Item 74)
- Yardstick (WP 0926 00, Item 87)

Equipment Condition

- Engine stopped (see your -10)
- Carrier blocked (see your -10)
- Rear power plant access panels removed (see your -10)
- Power plant access panels removed (WP 0439 00)

Personnel Required

Unit Mechanic

ADJUSTMENT

1. Check ventilating fan drive belt (1) for damage. If damaged, replace drive belt (WP 0243 00).
2. Position lower O-ring (2) on tensiometer (3) at maximum allowable belt deflection of 5/8 inch (1.6 cm).
3. Position upper O-ring (4) on tensiometer at zero (0).

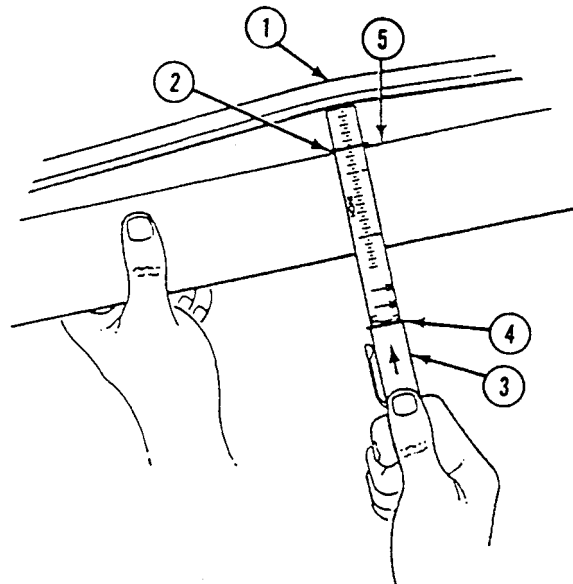
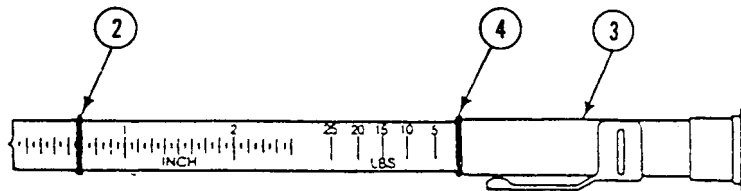

ADJUST VENTILATING FAN DRIVE BELT — Continued**0242 00**

4. Place yardstick (5) on pulleys (6) and (7).
5. Place tensiometer (3) on belt (1) at midspan and at right angle to belt.
6. Press on top of tensiometer (3) until lower O-ring (2) aligns with yardstick (5). Remove tensiometer.
7. Take tensiometer reading at point where upper O-ring (4) stopped. Reading must be 12-15 lbs (5-7 kg).
8. To change belt tension, loosen locknut (8) and adjust fan idler adjusting nut (9) to obtain tension required. Tighten locknut.

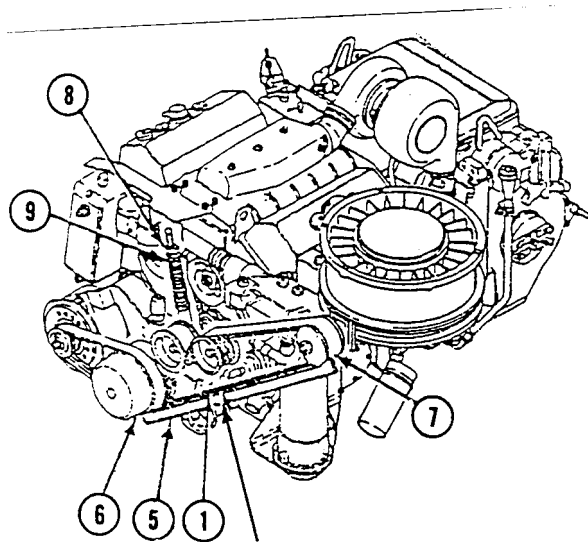
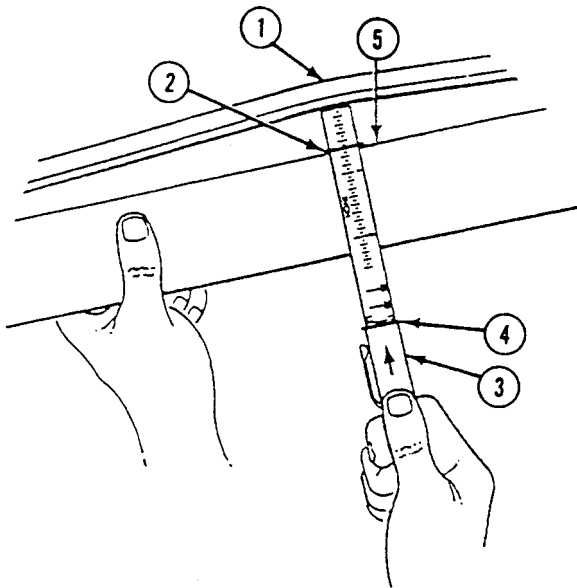
**FOLLOW-THROUGH STEPS**

1. Turn thermostatic fan speed switch bypass button ON (see your -10).
2. Start engine (see your -10).
3. Run in cooling fan belt for 10 minutes with engine at 2000 rpm.
4. Stop engine (see your -10).
5. Check belt tension. Adjust as needed.
6. Turn thermostatic fan speed switch bypass button OFF (see your -10).
7. Install power plant access panels (WP 0439 00)
8. Install rear power plant access panels (see your -10).

END OF TASK

REPLACE VENTILATING FAN DRIVE BELT

0243 00

THIS WORK PACKAGE COVERS:

Removal (page 0243 00-1).
 Installation (page 0243 00-2).

INITIAL SETUP:

Maintenance Level

Unit

References

See your -10

Tools and Special Tools

General Mechanic's Tool Kit (WP 0926 00, Item 65)
 Adjustable Wrench (WP 0926 00, Item 75)

Equipment Condition

Engine stopped (see your -10)
 Carrier blocked (see your -10)
 Power plant rear access panels removed (see your -10)
 Generator belt removed (WP 0253 00)
 Fan drive pulley access cover removed (WP 0440 00)

Materials/Parts

Fan drive belt

Personnel Required

Unit Mechanic

REMOVAL

1. Loosen locknut (1) that secures adjusting nut (2).
2. Rotate adjusting nut (2) to loosen fan drive belt (3). Discard fan drive belt (3). Use adjustable wrench.

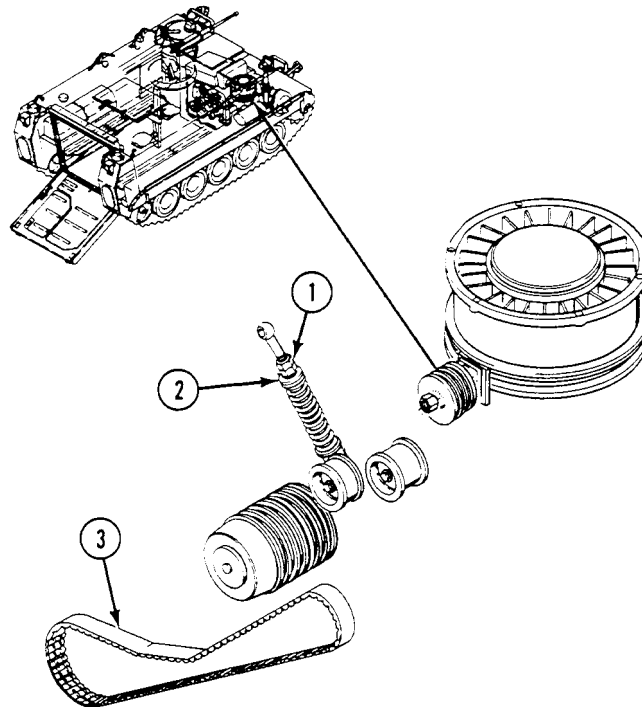

INSTALLATION**NOTE**

All pulleys should rotate freely before installing new fan drive belt.

Readjust new drive belt after 25-50 miles (40.23–80.45 Km) of carrier operation.

1. Position new fan drive belt (3) on pulleys.
2. Adjust fan drive belt (WP 0242 00).

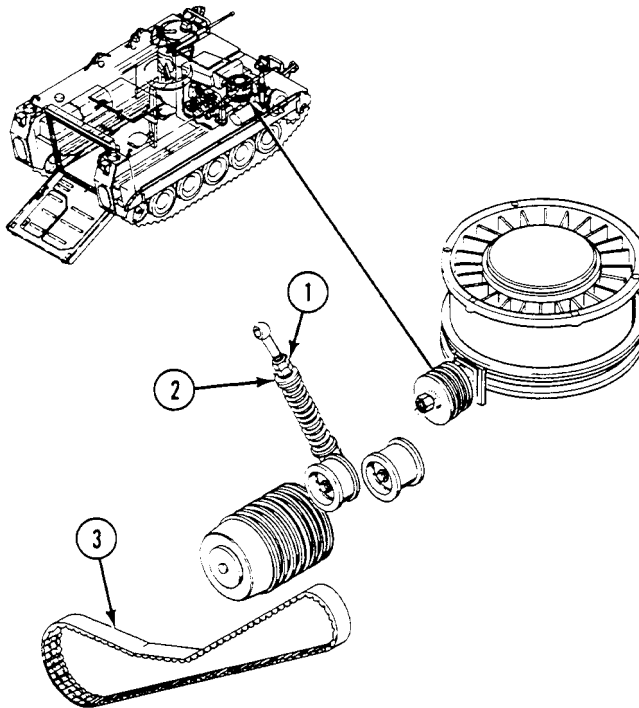
**FOLLOW-THROUGH STEPS**

1. Start engine (see your -10).
2. Check fan drive belt for proper operation.
3. Stop engine (see your -10).
4. Install generator belt (WP 0253 00).
5. Adjust generator belt (WP 0252 00).
6. Install fan drive pulley access cover (WP 0440 00).
7. Install power plant rear access panels (see your -10).

END OF TASK

REPLACE VENTILATING FAN DRIVE PULLEY

0244 00

THIS WORK PACKAGE COVERS:

- Removal (page 0244 00-1).
- Installation (page 0244 00-1).

INITIAL SETUP:

Maintenance Level

Unit

Personnel Required

Unit Mechanic

Tools and Special Tools

- General Mechanic's Tool Kit (WP 0926 00, Item 65)
- Mechanical Puller (WP 0926 00, Item 38)
- Torque Wrench (WP 0926 00, Item 80)

References

See your -10

Materials/Parts

- Key
- Locknut

Equipment Condition

- Engine stopped (see your -10)
- Carrier blocked (see your -10)
- Power plant grill raised (WP 0464 00)

REMOVAL

1. Remove locknut (1) and washer (2) from shaft of drive pulley (3). Discard locknut.
2. Remove pulley (3) and key (4) from shaft. Discard key. Use mechanical puller.

INSTALLATION

1. Install new key (4) in groove on fan drive shaft. Place pulley (3) on shaft and align groove in pulley with key on shaft. Tap pulley on shaft until pulley is seated on shaft.
2. Install washer (2) and new locknut (1) on shaft. **TIGHTEN LOCKNUT TO 75-81 LB-FT (102-111 N·M) TORQUE.**

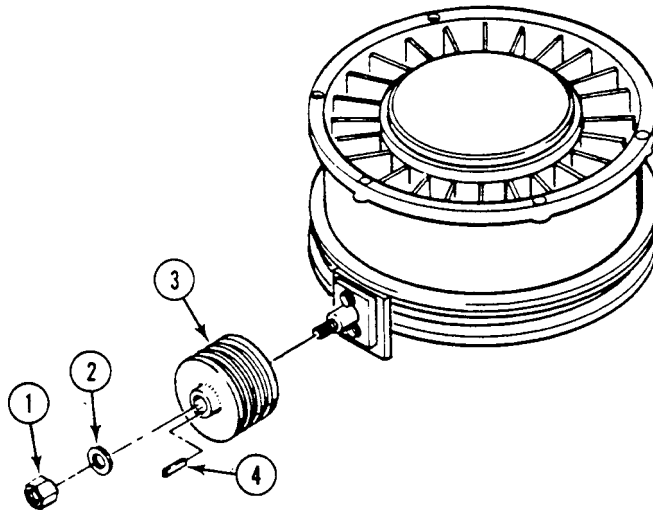

FOLLOW-THROUGH STEPS

1. Lower power plant grill (WP 0464 00).
2. Adjust ventilating fan drive belt (WP 0242 00).

END OF TASK

REPLACE FLAT PULLEYS AND BEARINGS

0245 00

THIS WORK PACKAGE COVERS:

Removal (page 0245 00-1).
 Installation (page 0245 00-3).

INITIAL SETUP:

Maintenance Level

Unit

References

See your -10

Tools and Special Tools

General Mechanic's Tool Kit (WP 0926 00, Item 65)
 Retaining Ring Pliers Set (WP 0926 00, Item 32)
 Torque Wrench (WP 0926 00, Item 82)

Equipment Condition

Engine stopped (see your -10)
 Carrier blocked (see your -10)
 Power plant rear access panels removed (see your -10)
 Ventilating fan drive belt removed (WP 0243 00)

Materials/Parts

Locknut
 Locknut (4)

Personnel Required

Unit Mechanic

REMOVAL

1. Remove four screws (1), locknuts (2), and panel support (3) from hull. Discard locknuts.

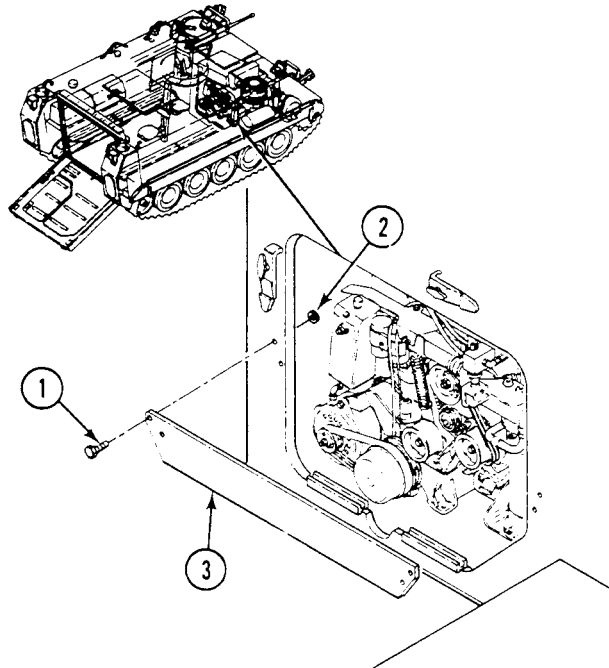

NOTE

Two pulleys are removed in the same way.

2. Remove locknut (4) and washer (5) from bolt (6). Discard locknut.
3. Remove bolt (6) and pulley (7) from bracket (8).

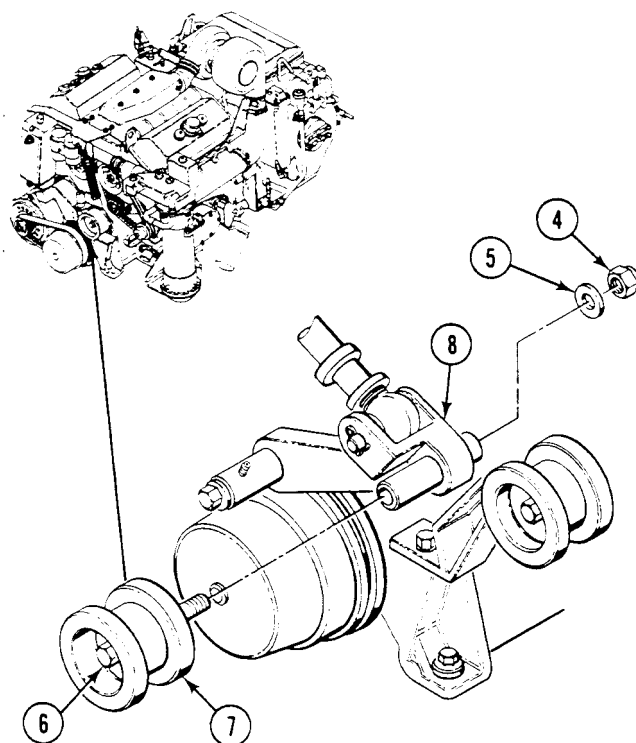

4. Remove bolt (1), ring (2), two bearings (3), and spacer (4) from pulley (5).

- Remove washer (6) and other ring (2) from pulley (5).

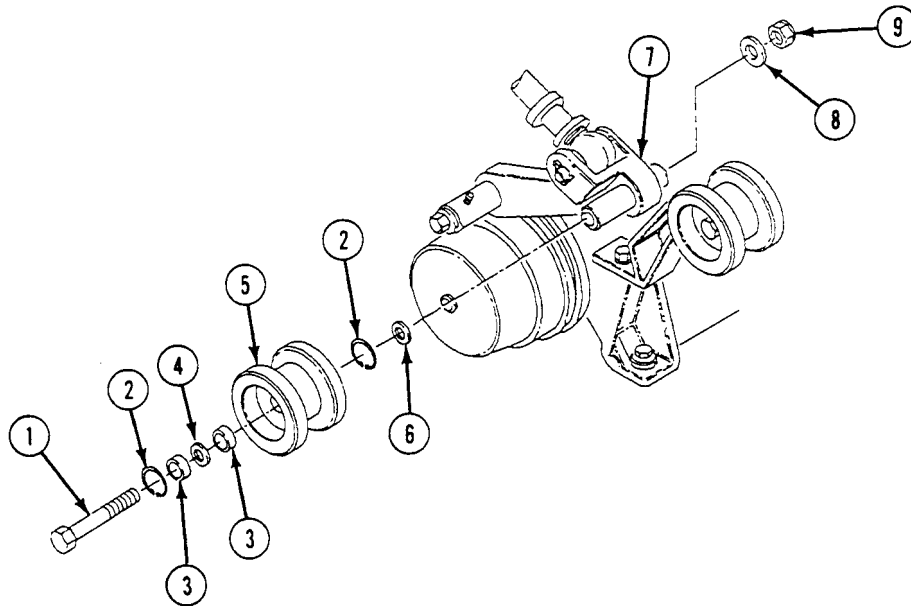

INSTALLATION

- Install ring (2) and washer (6) on pulley (5).
- Install bearing (3), spacer (4), second bearing (3) and other ring (2) on pulley (5).
- Install bolt (1) through two bearings (3) and bracket (7). Secure with washer (8) and new locknut (9). **TIGHTEN BOLT TO 50-55 LB-FT (68-75 N·M) TORQUE.**

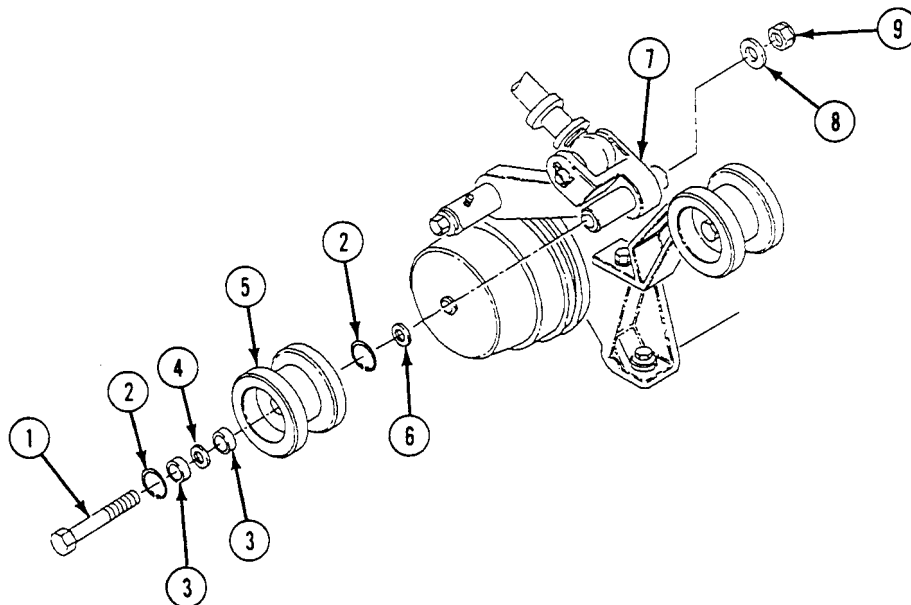

4. Install panel support (10) on hull. Secure with four screws (11) and new locknuts (12).

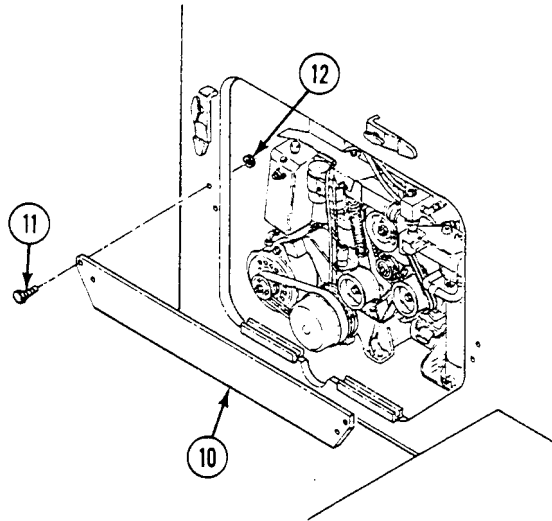
**FOLLOW-THROUGH STEPS**

1. Install power plant rear access panels (see your -10).
2. Install ventilating fan drive belt (WP 0243 00).

END OF TASK

REPLACE IDLER ARM AND SPRING TENSIONER

0246 00

THIS WORK PACKAGE COVERS:

Removal (page 0246 00-1).
 Installation (page 0246 00-2).

INITIAL SETUP:

Maintenance Level

Unit

References

See your -10

Tools and Special Tools

General Mechanic's Tool Kit (WP 0926 00, Item 65)

Equipment Condition

Engine stopped (see your -10)

Carrier blocked (see your -10)

Power plant lower rear access panel removed (see your -10)

Materials/Parts

Cotter pin (2)

Locknut

Flat pulley removed (WP 0245 00)

Personnel Required

Unit Mechanic

REMOVAL

1. Remove cotter pin (1) and pin (2) from bracket (3). Discard cotter pin.
2. Remove cotter pin (4) and pin (5) from idler arm (6). Remove spring tensioner (7). Discard cotter pin.

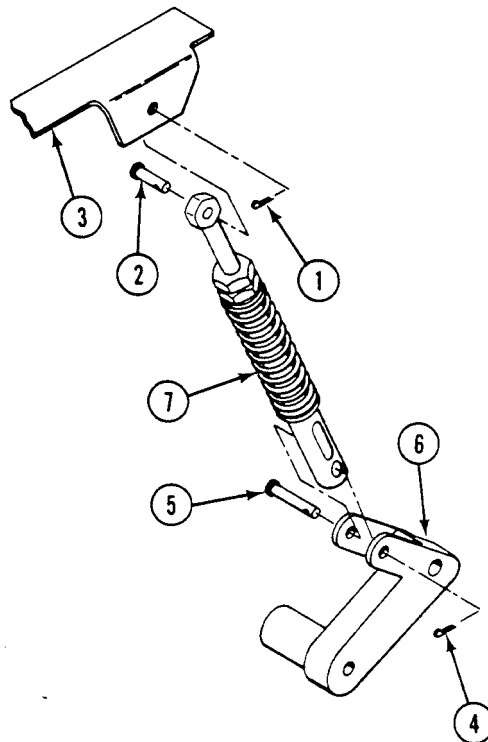

- Remove screw (8), washer (9), and locknut (10) from idler arm (6) and bracket (11). Remove idler arm. Discard locknut.

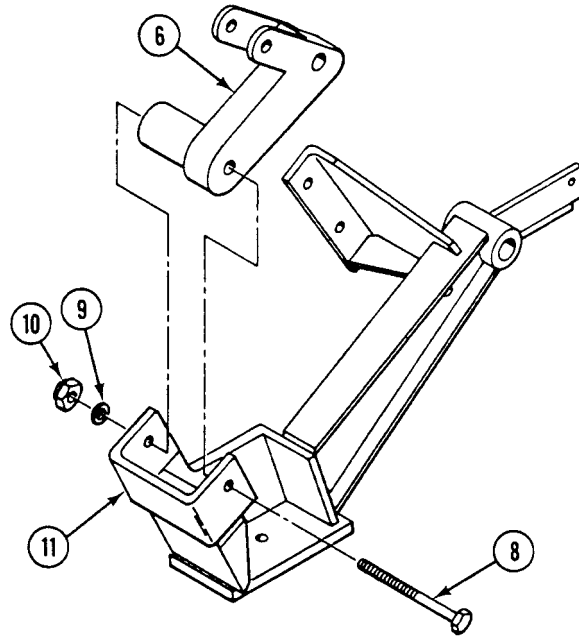

INSTALLATION

- Install idler arm (1) on bracket (2) and secure with screw (3), washer (4), and new locknut (5).

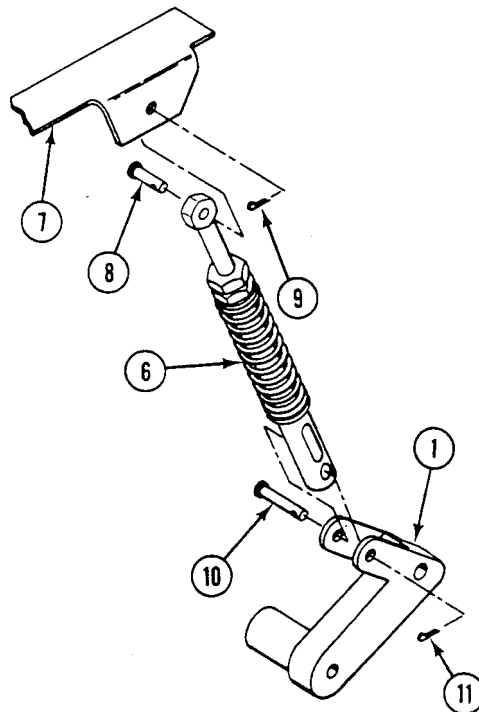

REPLACE IDLER ARM AND SPRING TENSIONER — Continued

0246 00

2. Install spring tensioner (6) on bracket (7). Secure with pin (8) and new cotter pin (9).
3. Install spring tensioner (6) on idler arm (1). Secure with pin (10) and new cotter pin (11).

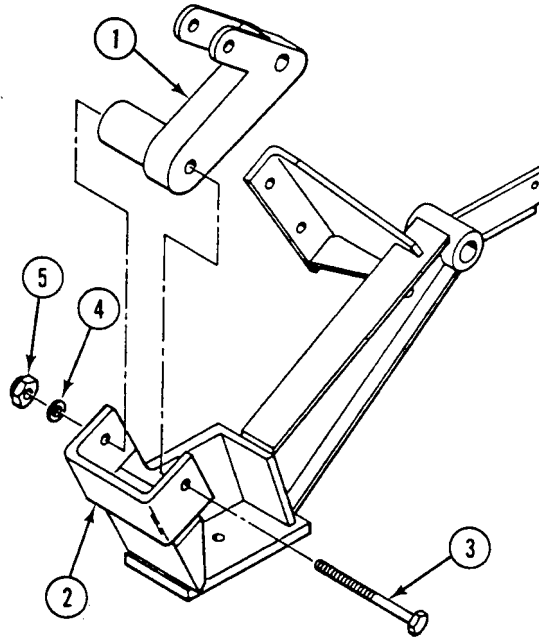
**FOLLOW-THROUGH STEPS**

1. Install flat pulley (WP 0245 00).
2. Install power plant lower rear access panel (see your -10).

END OF TASK

REPLACE VENTILATING FAN ASSEMBLY

0247 00

THIS WORK PACKAGE COVERS:

Removal (page 0247 00-2).
 Installation (page 0247 00-3).

INITIAL SETUP:

Maintenance Level

Unit

Personnel Required

Unit Mechanic

Tools and Special Tools

General Mechanic's Tool Kit (WP 0926 00, Item 65)
 Sling (WP 0926 00, Item 47)
 Torque Wrench (WP 0926 00, Item 82)
 Lifting Device

References

See your -10

Equipment Condition

Engine stopped (see your -10)
 Carrier blocked (see your -10)
 Power plant grill raised (WP 0464 00)

REMOVAL

1. Attach sling and suitable lifting device of at least 150 lbs (68 kg) capacity to fan assembly.
2. Remove six screws (1) and washers (2) that secure fan assembly (3) to power plant grill (4).
3. Lift fan assembly (3) from power plant grill (4) and place fan assembly on work bench or a flat wooden board.
4. Remove fan drive pulley (5) from fan assembly (3) (WP 0244 00).
5. Drain fan drive right angle gearbox (6) (WP 0155 00-0 106) .

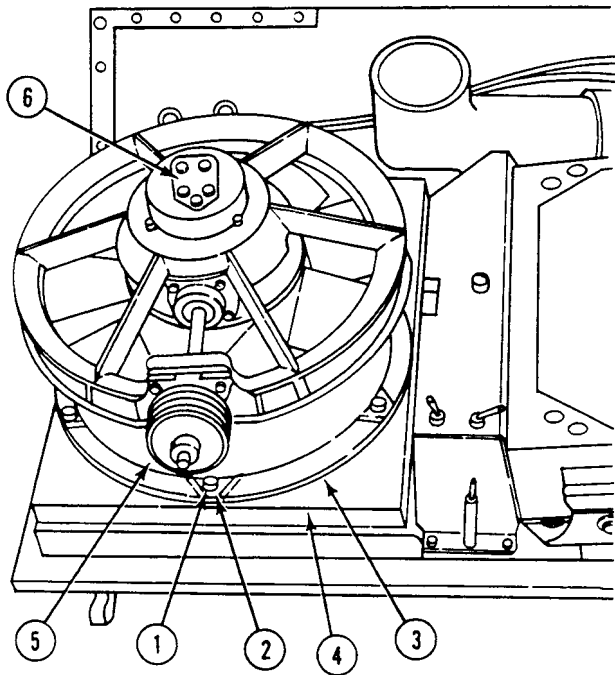

INSTALLATION**NOTE**

Fill on level ground.

1. Fill fan drive right angle gearbox (6) (WP 0155 00).
2. Install fan drive pulley (1) on fan assembly (2) (WP 0244 00).
3. Attach sling and suitable lifting device of at least 150 lbs (68 kg) capacity to fan assembly (2). Lift fan assembly and install on power plant grill (3).
4. Install six screws (4) and washers (5). TIGHTEN SCREWS TO 24-28 LB-FT (33-38 N·M) TORQUE.

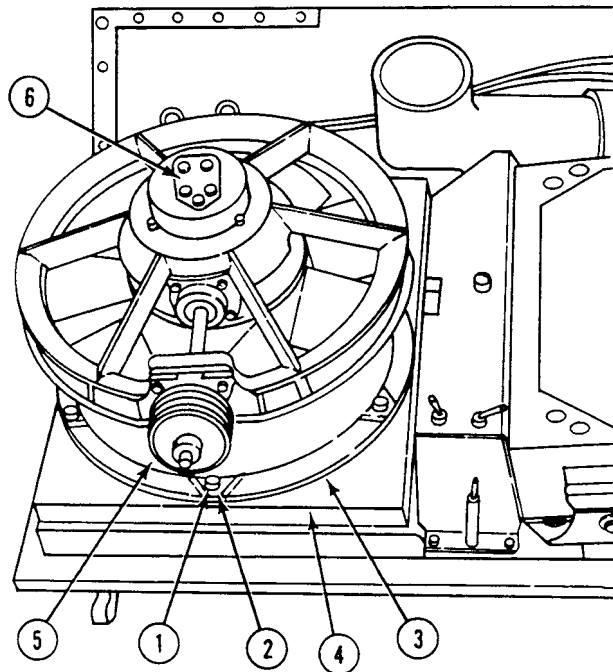
**FOLLOW-THROUGH STEPS**

1. Lower power plant grill (WP 0464 00).

END OF TASK

REPLACE FAN DRIVE SHAFT AND BEARING HOUSING

0248 00

THIS WORK PACKAGE COVERS:

Removal (page 0248 00-1).
 Installation (page 0248 00-3).

INITIAL SETUP:

Maintenance Level

Unit

References

See your -10

Tools and Special Tools

General Mechanic's Tool Kit (WP 0926 00, Item 65)
 Torque Wrench (WP 0926 00, Item 85)

Equipment Condition

Engine stopped (see your -10)
 Carrier blocked (see your -10)
 Battery ground strap removed (WP 0337 00),
 (WP 0338 00), or (WP 0339 00)
 Power plant rear access panel removed (see your -10)
 Fan drive gear box drained (WP 0155 00)
 Power plant grill raised (WP 0464 00)
 Fan drive pulley removed (WP 0244 00)

Materials/Parts

Antiseize compound (WP 0928 00, Item 11)
 Packing
 Washer (3)

Personnel Required

Unit Mechanic

REMOVAL

WARNING



Failure to set the parking brake and block the road wheels can allow the carrier to move and could result in injury or death. Always set the parking brake and block road wheels before working on the carrier.

1. Remove two pins (1) from bearing housing (2) and bearing support (3). Tap pins in toward center of fan.

2. Remove three screws (4), washers (5), bearing housing (2), and drive shaft (6) from bearing support (3). Discard washers.

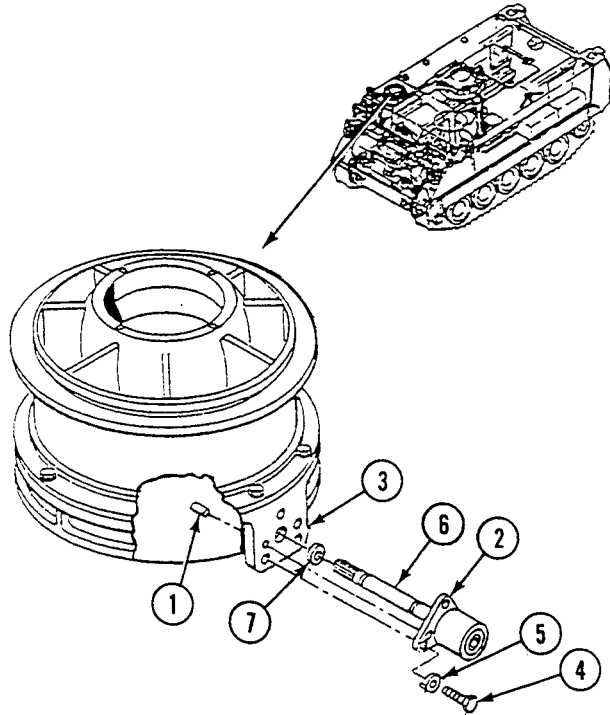

3. Remove packing (7) from drive shaft (6). Discard packing.

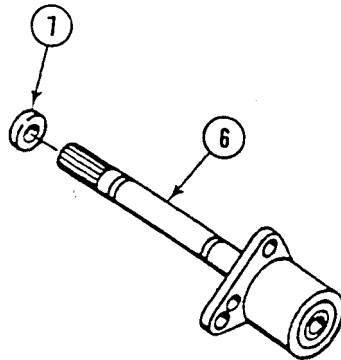

INSTALLATION

1. Install new packing (1) on drive shaft (2).

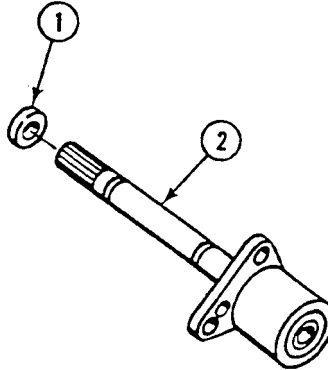

2. Align splines of drive shaft (2) with fan gear box splines (3). Install drive shaft in bearing support (4) and gear box (3).
3. Install two pins (5) in bearing housing (6) and bearing support (4). Tap pins in toward center of fan.
4. Apply antiseize compound to threads of screws (7).
5. Install three new washers (8) and screws (7) in bearing housing (6). **TIGHTEN SCREWS (7) TO 21-25 LB-FT (28-34 N·m) TORQUE.**

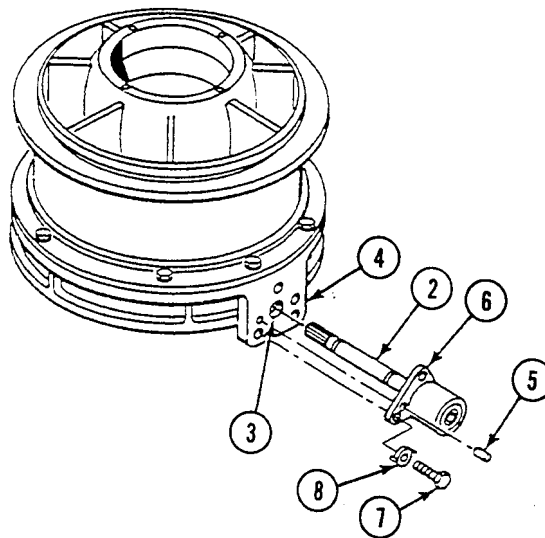
**FOLLOW-THROUGH STEPS**

1. Install fan drive pulley (WP 0244 00).
2. Lower power plant grill (WP 0464 00).
3. Fill fan drive gear box (WP 0155 00).
4. Install power plant rear access panel (see your -10).
5. Connect battery ground strap (WP 0337 00), (WP 0338 00), or (WP 0339 00).

END OF TASK

REPLACE FAN AND GENERATOR VARIABLE SPEED FAN DRIVE (OLD CONFIGURATION)

0249 00

THIS WORK PACKAGE COVERS:

Removal (page 0249 00-1).
 Installation (page 0249 00-3).

INITIAL SETUP:

Maintenance Level

Unit

References

See your -10

Tools and Special Tools

General Mechanic's Tool Kit (WP 0926 00, Item 65)
 Torque Wrench (WP 0926 00, Item 85)

Equipment Condition

Engine stopped (see your -10)
 Carrier blocked (see your -10)
 Power plant rear access panels removed (see your -10)
 Fan drive belt removed (WP 0243 00)
 Generator drive belt removed (WP 0253 00)

Materials/Parts

Packing
 Packing
 Packing

Personnel Required

Unit Mechanic

REMOVAL**NOTE**

Of the three hoses removed, left hose is the lube port hose, center hose is the return hose, and right hose is the pressure hose.

1. Disconnect three hoses (1), (2), and (3) from drive assembly (4).
2. Remove six screws (5), washers (6), and drive assembly (4).
3. Remove three elbows (7), (8), and (9) and packings (10), (11), and (12) from drive assembly (4). Discard packings.

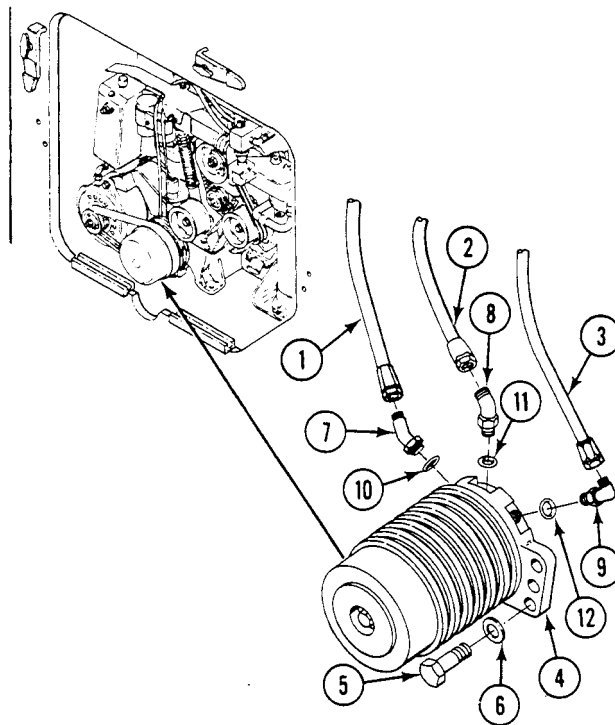

REPLACE FAN AND GENERATOR VARIABLE SPEED FAN DRIVE (OLD CONFIGURATION)
 — Continued

0249 00

INSTALLATION

1. Install three elbows (7), (8), and (9) and new packings (10), (11), and (12) on drive assembly (4).
2. Install drive assembly (4) on engine. Secure with six screws (5) and washers (6). **TIGHTEN SCREWS TO 32-34 LB-FT (43-46 N·M) TORQUE.**
3. Connect three hoses (1), (2), and (3) to drive assembly (4).

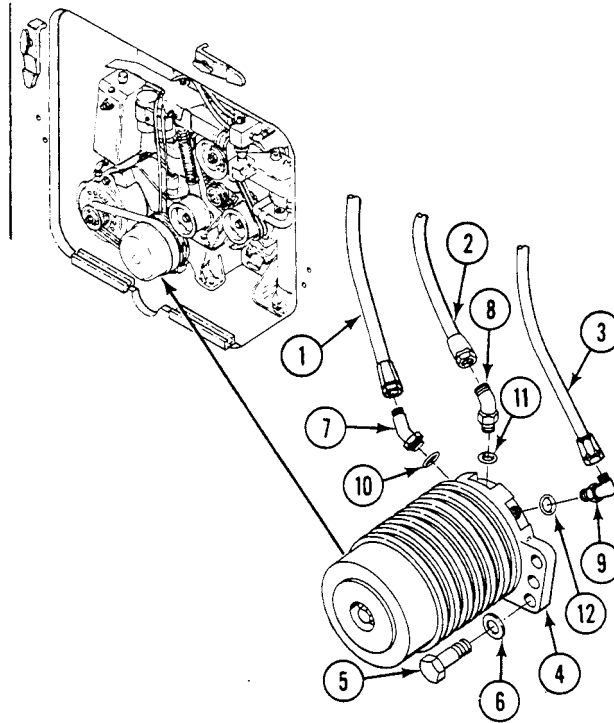
**FOLLOW-THROUGH STEPS**

1. Install fan drive belt (WP 0243 00).
2. Adjust fan drive belt (WP 0242 00).
3. Install generator drive belt (WP 0253 00).
4. Adjust generator drive belt (WP 0252 00).
5. Install power plant rear access panels (see your -10).

END OF TASK

REPLACE VARIABLE SPEED FAN DRIVE ASSEMBLY (NEW CONFIGURATION)

0249 01

THIS WORK PACKAGE COVERS:

- Removal (page 0231 01-1).
 - Installation (page 0231 01-2).
 - Adjustment (page 0231 01-2).
-

INITIAL SETUP:Maintenance Level

Unit

Tools and Special Tools

- General Mechanic's Tool Kit (WP 0926, Item 65)
- Torque Wrench (WP 0926, Item 85)

Materials/Parts

- Molybdenum grease (WP 0928, Item 41)
- Sealing compound (WP 0928, Item 52)
- Packing, preformed
- Packing, preformed

Personnel Required

Unit Mechanic

References

- See your -10
- Drawing 12474790

Equipment Conditions

- Engine stopped (see your -10)
 - Carrier blocked (see your -10)
 - Power plant rear access panels removed (see your -10)
 - Driver's power plant access panel removed (see your-10)
 - Battery ground strap disconnected (WP 0337 00 or WP 0338 00)
 - Fan drive belt removed (WP 0243 00)
 - Generator drive belt removed (WP 0253 00)
-

REMOVAL

1. Disconnect plugs (1) from drive assembly (2).
2. Remove sensor (3) from drive assembly (2).

NOTE

Of the two hoses removed, the left hose is the lube port and the right hose is the return hose.

3. Disconnect two hoses (4) and (5) from elbows (6) and (7) on drive assembly (2).
4. Remove six screws (8), washers (9), and drive assembly (2).
5. Remove two elbows (6) and (7), packings (10) and (11), and one adapter (12) from drive assembly (2). Discard packing.

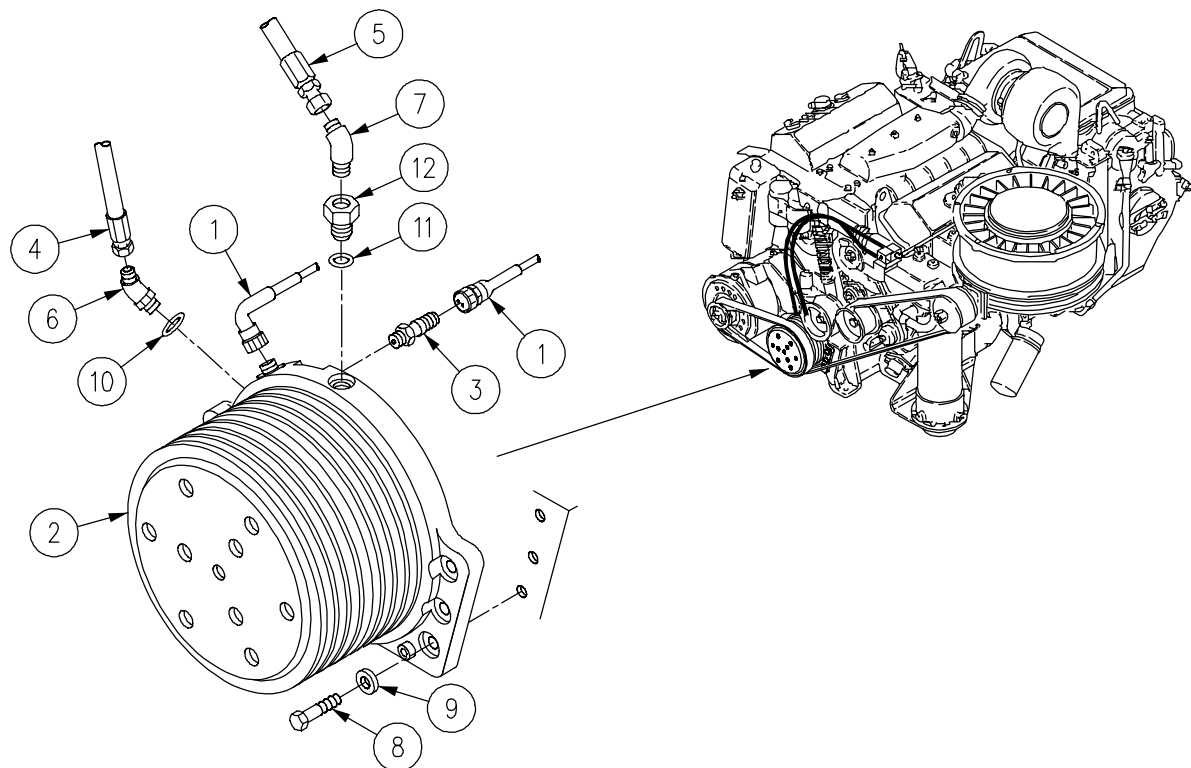

INSTALLATION

1. Apply thin layer of sealing compound to male threads on return hose elbow (7). Install adapter (12), two new packings (10) and (11), and elbows (6) and (7) on drive assembly (2).
2. Apply molybdenum grease to splines of drive assembly (2). Install drive assembly (2), six washers (9), and screws (8). TORQUE SCREWS TO 32-34 LB-FT (43-46 N·M) TORQUE.
3. Connect two hoses (4) and (5) to elbows (6) and (7) on drive assembly (2).
4. Install sensor (3) on drive assembly (2).
5. Connect plugs (1) on drive assembly (2).

ADJUST

1. Adjust sensor (3) so sensor tip is .030-.040 inch (8-11 mm) from drive pulley (2).

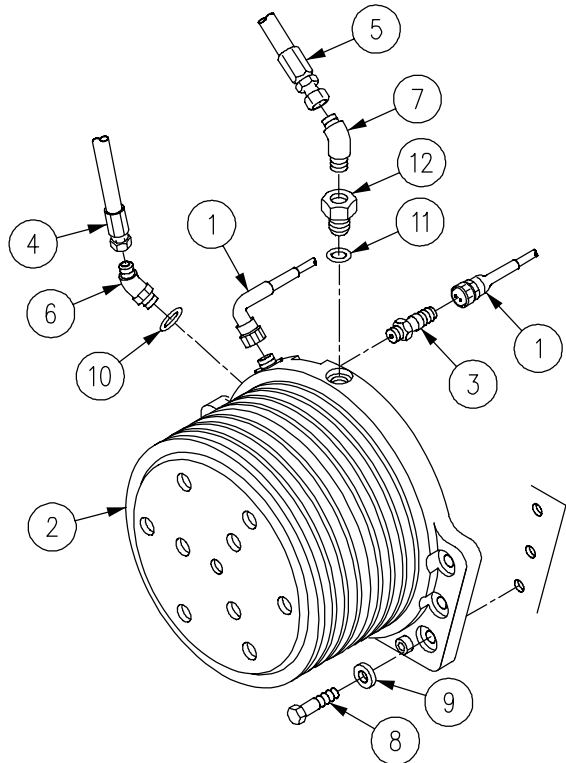

FOLLOW-THROUGH STEPS

1. Install generator drive belt (WP 0253 00).
2. Install fan drive belt (WP 0243 00).
3. Connect battery ground strap (WP 0337 00 or WP 0338 00).
4. Install driver's power plant access panel (see your-10).
5. Install power plant rear access panels (see your -10).

END OF TASK

**REPLACE HOSES FROM THERMOSTAT TO VARIABLE SPEED FAN DRIVE
(OLD CONFIGURATION)**

0250 00

THIS WORK PACKAGE COVERS:

Removal (page 0250 00-1).
Installation (page 0250 00-4).

INITIAL SETUP:

Maintenance Level

Unit

References

See your -10

Tools and Special Tools

General Mechanic's Tool Kit (WP 0926 00, Item 65)

Equipment Condition

Engine stopped (see your -10)
Carrier blocked (see your -10)
Power plant rear access panels removed (see your -10)
Power plant rear access panel support removed
(WP 0439 00)
Ventilating fan drive belt removed (WP 0243 00)

Materials/Parts

Locknut
Packing (2)
Packing (2)
Strap (1)

Personnel Required

Unit Mechanic

REPLACE HOSES FROM THERMOSTAT TO VARIABLE SPEED FAN DRIVE (OLD CONFIGURATION) — Continued

0250 00

REMOVAL

1. Remove strap (1) securing hoses (2) and (3) from variable speed fan drive (4). Discard strap.

NOTE

Install covers on disconnected hydraulic lines, tubes, valves and components during maintenance. Use tape, cloth, cardboard, or any appropriate material to prevent damage to components or accidental hydraulic fluid spills.

2. Remove lube port hose (2) from elbow (5) on variable speed fan drive (4).
3. Remove pressure hose (3) from elbow (6) on variable speed fan drive (4).
4. Remove elbow (5) and packing (7) from variable speed fan drive (4). Discard packing.
5. Remove elbow (6) and packing (8) from variable speed fan drive (4). Discard packing.

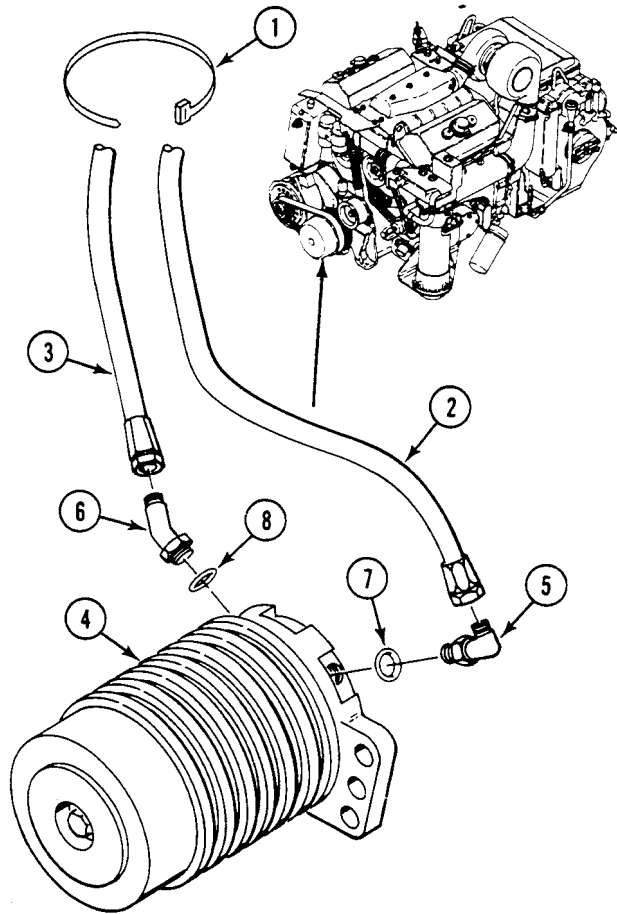

REPLACE HOSES FROM THERMOSTAT TO VARIABLE SPEED FAN DRIVE (OLD CONFIGURATION) — Continued

0250 00

6. Remove hose (1) from adapter (2).
7. Remove hose (3) from adapter (4).
8. Remove adapter (2) and packing (5) from thermostat housing (6). Discard packing.
9. Remove adapter (4) and packing (7) from thermostat housing (6). Discard packing.

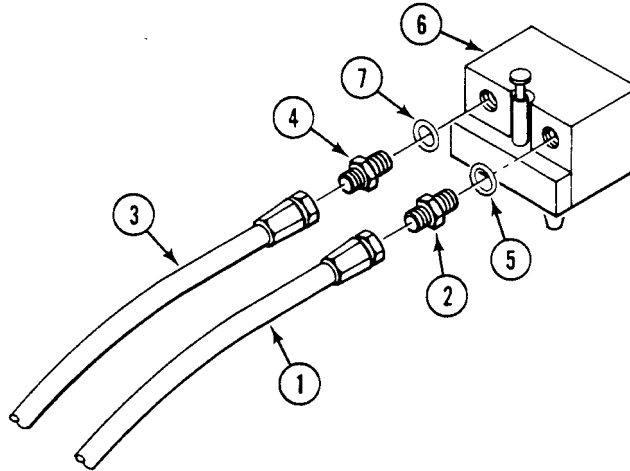

10. Remove screw (8), two washers (9), locknut (10) and two clamps (11) and (12) from bracket (13). Remove two clamps from hoses (3) and (1). Discard locknut.

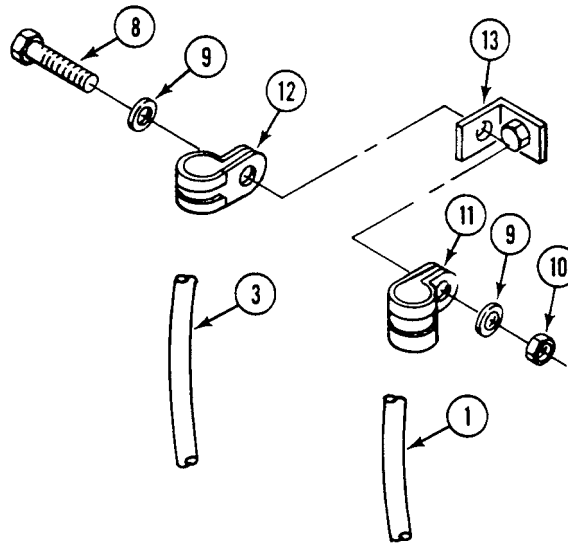

REPLACE HOSES FROM THERMOSTAT TO VARIABLE SPEED FAN DRIVE (OLD CONFIGURATION) — Continued

0250 00

INSTALLATION

1. Install elbow (14) and new packing (15) on variable speed fan drive (16).
2. Install elbow (17) and new packing (18) on variable speed fan drive (16).

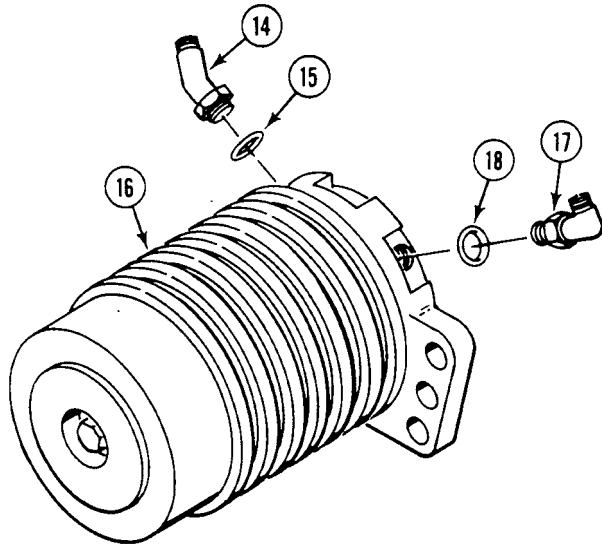

3. Install adapter (19) and new packing (20) on thermostat housing (21).
4. Install adapter (22) and new packing (23) on thermostat housing (21).
5. Install hose (24) on adapter (19).
6. Install hose (25) on adapter (22).

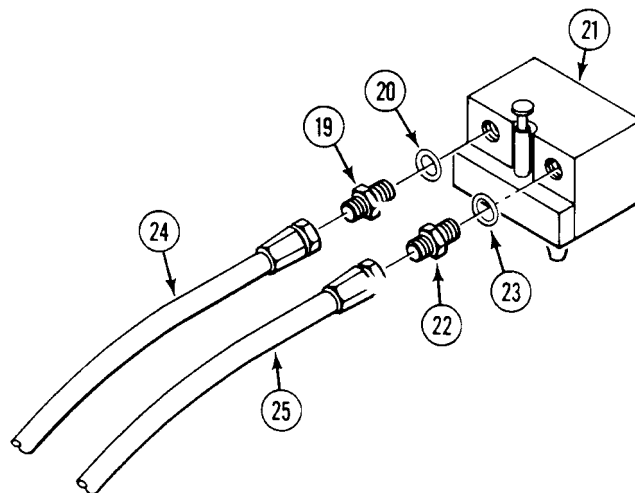

REPLACE HOSES FROM THERMOSTAT TO VARIABLE SPEED FAN DRIVE (OLD CONFIGURATION) — Continued

0250 00

7. Install two clamps (1) and (2) on two hoses (3) and (4). Secure clamps to bracket (5) with screw (6), two washers (7) and locknut (8).

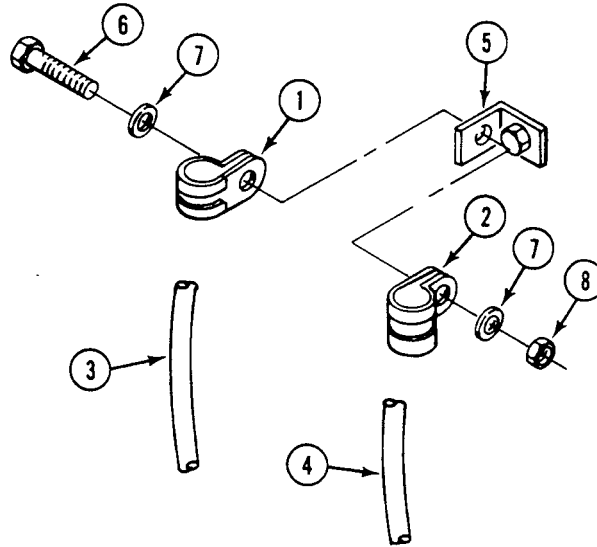

8. Install hose (3) on elbow (9).
9. Install hose (4) on elbow (10).
10. Secure hoses (3) and (4) together to variable speed fan drive with new strap (11).

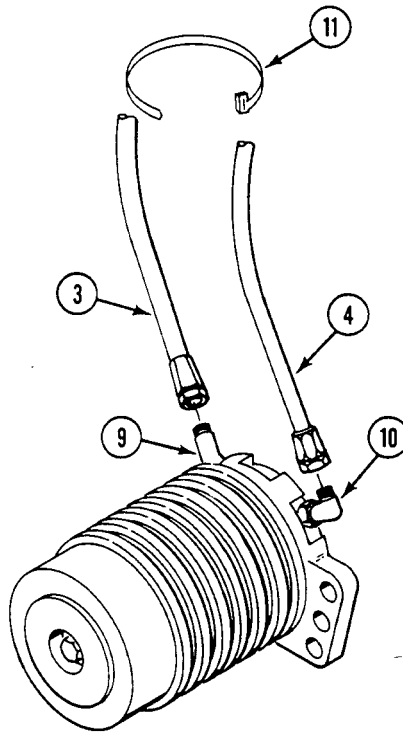

REPLACE HOSES FROM THERMOSTAT TO VARIABLE SPEED FAN DRIVE (OLD CONFIGURATION) — Continued

0250 00

FOLLOW-THROUGH STEPS

1. Install ventilating fan drive belt (WP 0243 00).
2. Adjust ventilating fan drive belt (WP 0242 00).
3. Install power plant rear access panel support (WP 0439 00).
4. Install power plant rear access panels (see your -10).

END OF TASK

REPLACE VARIABLE SPEED FAN DRIVE CONTROLLER (NEW CONFIGURATION)

THIS WORK PACKAGE COVERS:

Removal (page 0250 01-1)

Installation (page 0250 01-2)

INITIAL SETUP:

Maintenance Level

Unit

Tools and Special Tools

General Mechanic's Tool Kit (WP 0926 00, Item 65)

Materials/Parts

Gasket

Lockwasher (2)

Lockwasher (2)

Lockwasher (4)

Personnel Required

Unit Mechanic

References

See your -10

Equipment Conditions

Engine stopped (see your -10)

Carrier blocked (see your -10)

Driver's power plant access panel removed (see your-10)

Battery ground strap disconnected (WP 0337 00 or WP 0338 00)

REMOVAL

1. Disconnect two wiring harnesses (1) and (2) from controller (3) on driver's compartment engine bulkhead.
2. Remove nut (4), screw (5), lockwasher (6), and controller jumper wire (7) from vehicle. Discard lockwasher.
3. Remove two lockwashers (8), flat washers (9), screws (10), bracket (11), and gasket (12) from driver's compartment engine bulkhead. Discard lockwashers and gasket.
4. Remove four nuts (13), jumper wire (7), lockwasher (14), four lockwashers (15), seven flat washers (16), four screws (17), and controller (3) from bracket (11). Discard lockwashers.

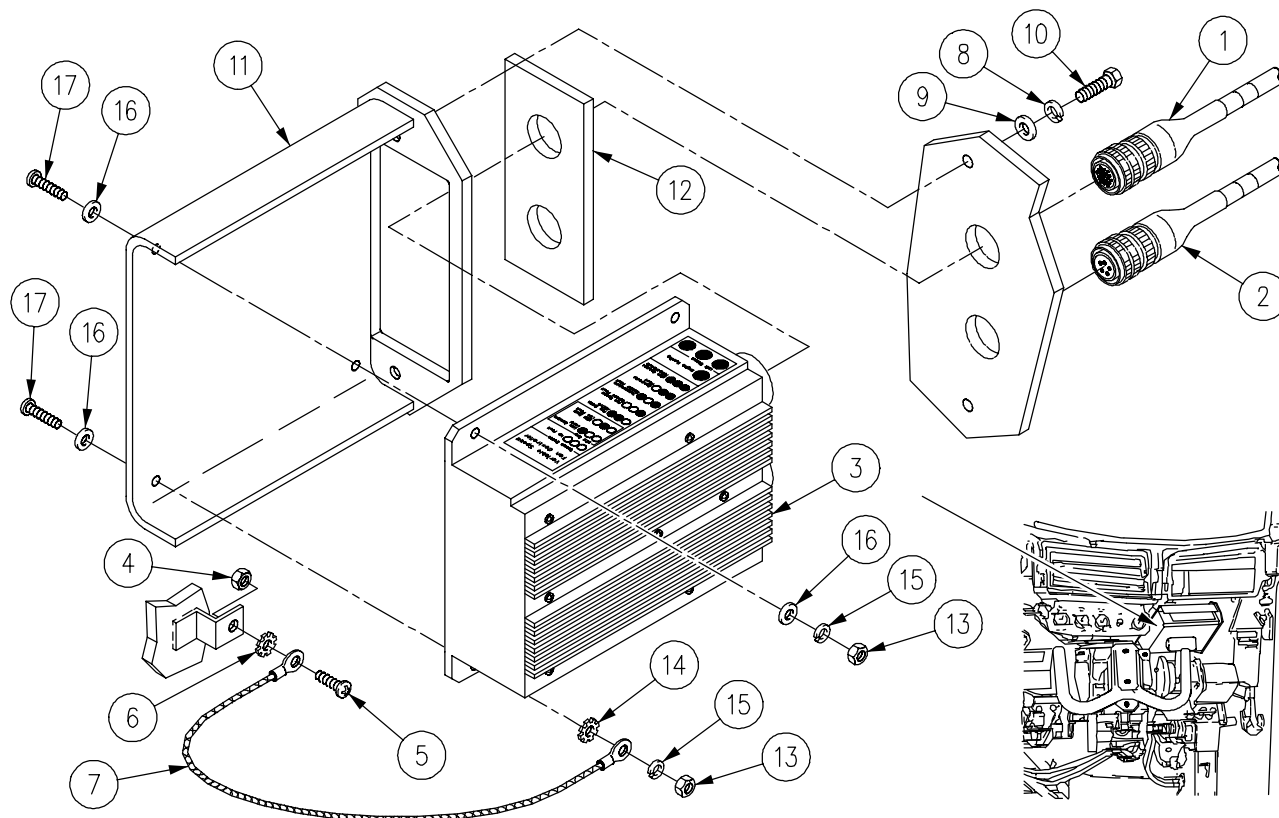

**REPLACE VARIABLE SPEED FAN DRIVE CONTROLLER
(NEW CONFIGURATION) - Continued**

0250 01

INSTALLATION

1. Install controller (3), four screws (17), seven flat washers (16), four new lockwashers (15), new lockwasher (14), jumper wire (7), and four nuts (13) on bracket (11).
2. Install new gasket (12), bracket (11), two screws (10), flat washers (9), and new lockwashers (8) on driver's compartment engine bulkhead.
3. Install nut (4), screw (5), new lockwasher (6), and controller jumper wire (7) on vehicle.
4. Connect two wiring harnesses (1) and (2) on controller (3) on driver's compartment engine bulkhead.

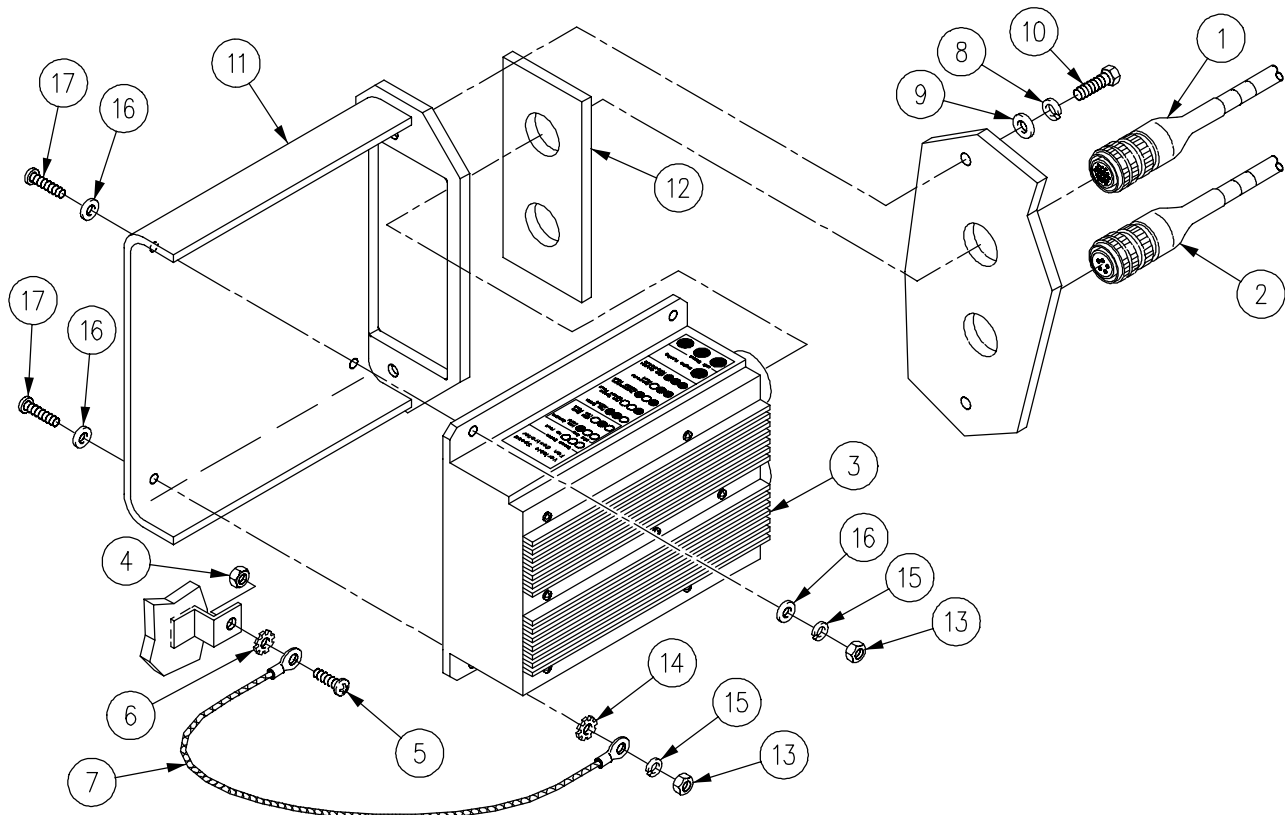
FOLLOW-THROUGH STEPS

1. Connect battery ground strap (WP 0337 00 or WP 0338 00).
2. Install driver's power plant access panel (see your-10).

END OF TASK

REPLACE TRANSMISSION OIL SUPPLY AND RETURN HOSES

0251 00

THIS WORK PACKAGE COVERS:

Removal (page 0251 00-1).
 Installation (page 0251 00-5).

INITIAL SETUP:

Maintenance Level

Unit

Personnel Required

Unit Mechanic

Tools and Special Tools

General Mechanic's Tool Kit (WP 0926 00, Item 65)

References

See your -10

Materials/Parts

Packing
 Locknut
 Transmission oil (WP 0928 00, Item 28)

Equipment Condition

Engine stopped (see your -10)
 Carrier blocked (see your -10)
 Power plant removed (WP 0156 00)
 Transmission oil drained (WP 0398 00)

REMOVAL

CAUTION

Cap or cover openings where oil lines or fittings have been removed.

NOTE

Old and New Configuration refers to variable speed fan drive configuration.

1. Remove return hose (1) from elbow (2).
2. Remove elbow (2) from transmission.

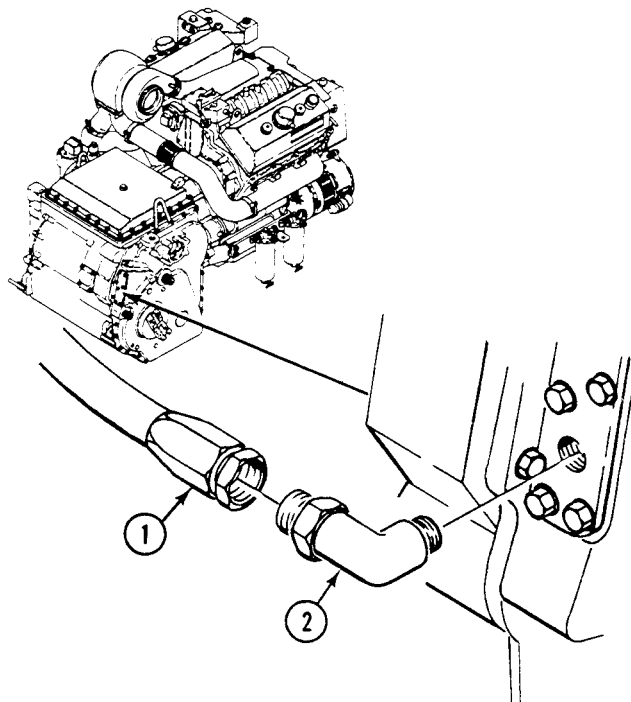

3. Remove two nuts (3), screws (4), four washers (5), and two clamps (6) that secure hose (1) to two brackets (7) on transmission.

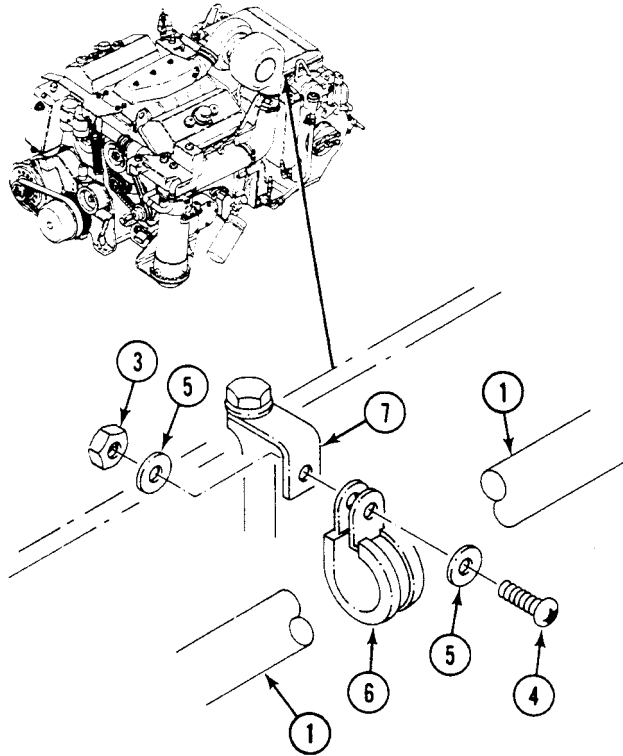

REPLACE TRANSMISSION OIL SUPPLY AND RETURN HOSES — Continued

0251 00

4. Remove supply hose (1) from elbow (2).
5. Remove elbow (2) from transmission.

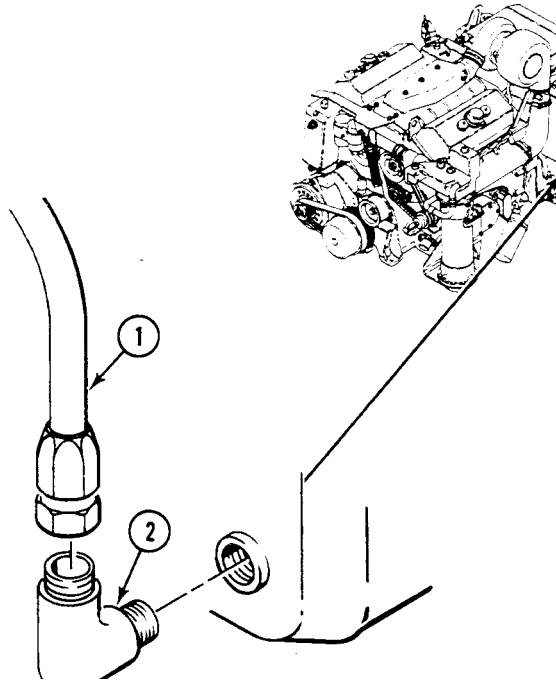

6. Remove supply hose (1) from elbow (3). Remove hose.
7. Remove elbow (3) and preformed packing (4) from thermostat housing (4.1) (Old Configuration), or valve (4.2) (New Configuration). Discard packing.

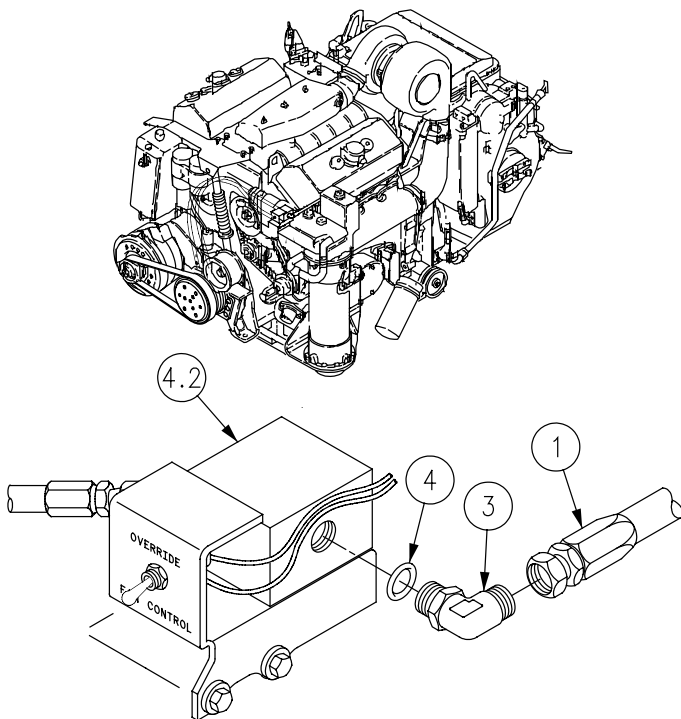

NEW CONFIGURATION

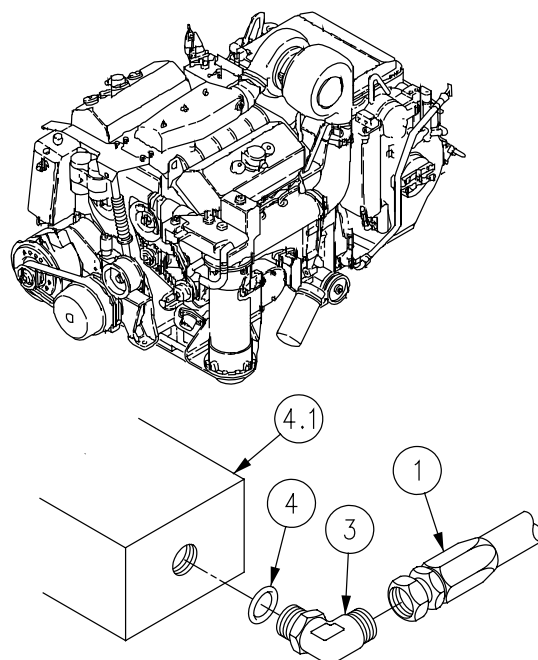

OLD CONFIGURATION

8. Remove hose (5) from elbow (6).
9. Remove elbow (6) from adapter (7).
10. Remove adapter (7) and packing (7.1) from variable speed fan drive (8). Discard packing.

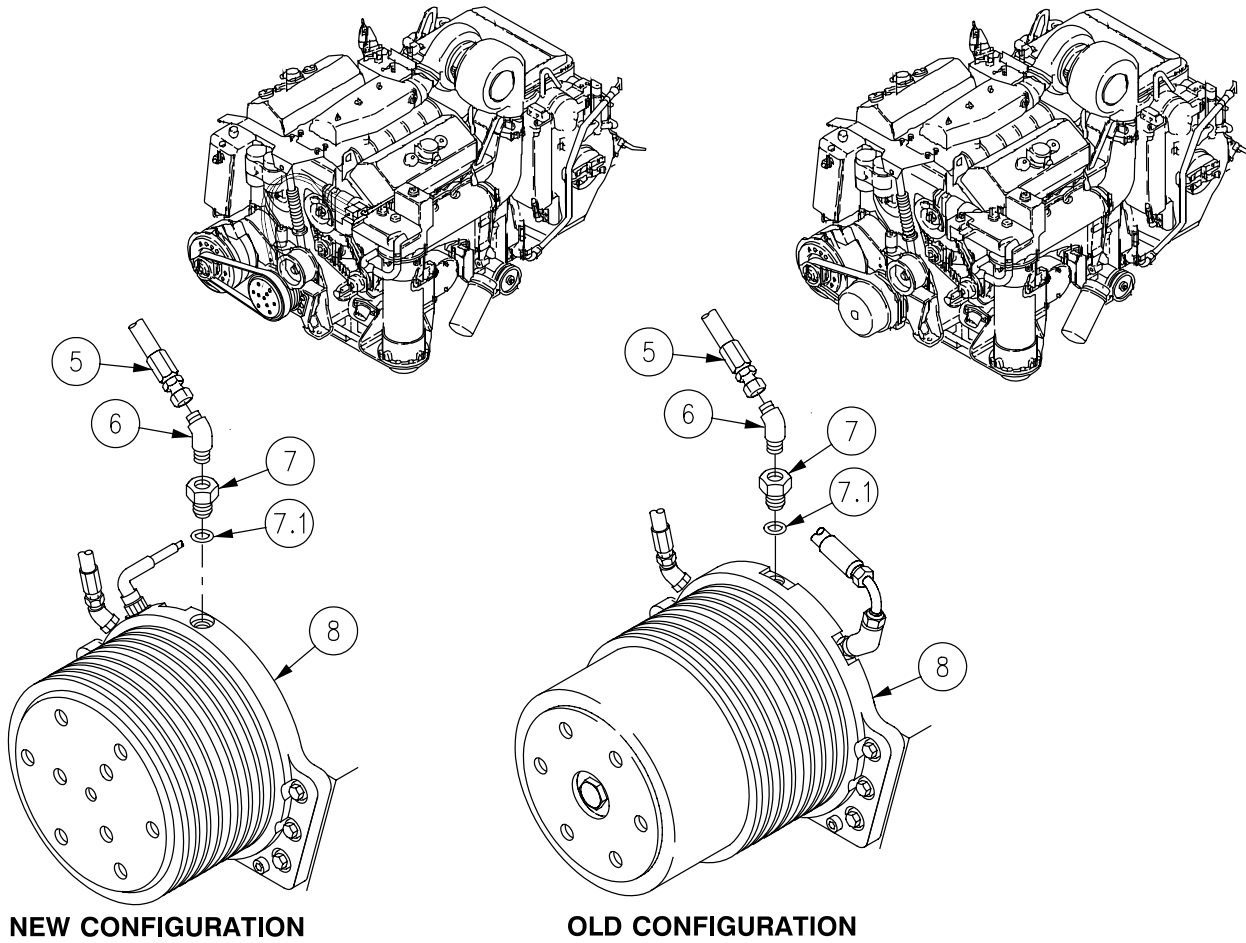

- Remove screw (1), two washers (2), locknut (3), and clamp (4) from hose (5). Discard locknut. Remove hose.

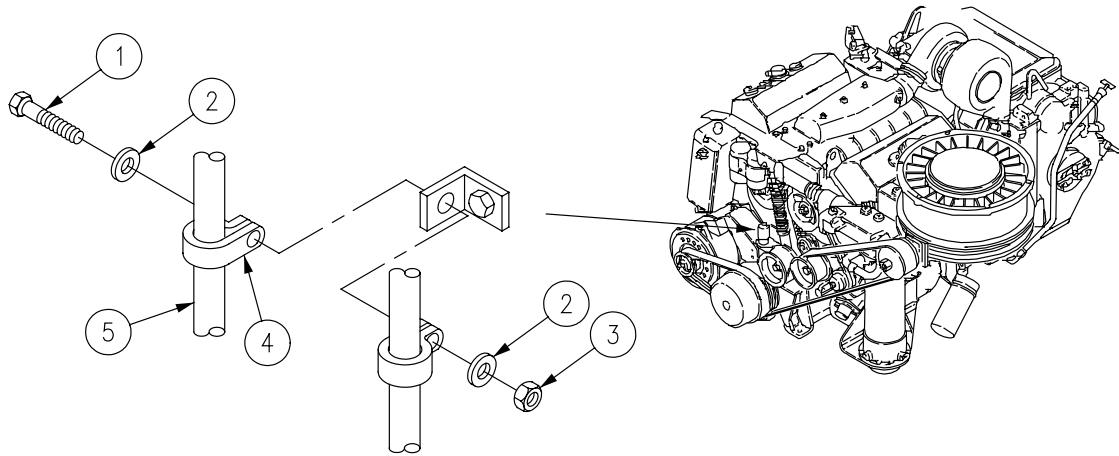

INSTALLATION

- Install adapter (6) and new packing (7.1) on variable speed fan drive (7).
- Install elbow (8) on adapter (6).

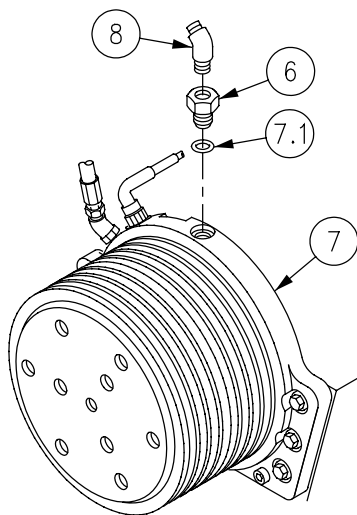

NEW CONFIGURATION

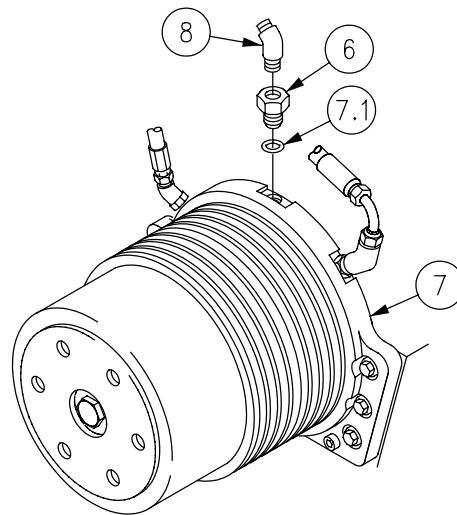

OLD CONFIGURATION

3. Install elbow (9) and new packing (10) on thermostat housing (11) (Old Configuration) or valve (11.1) (New Configuration).

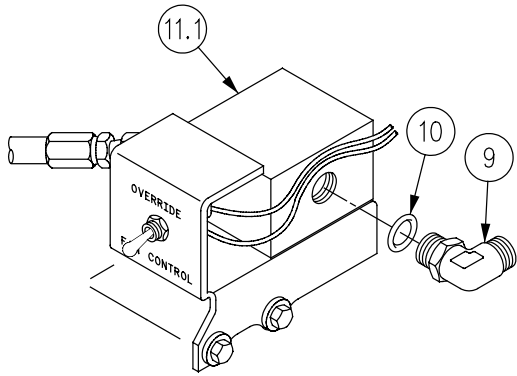

NEW CONFIGURATION

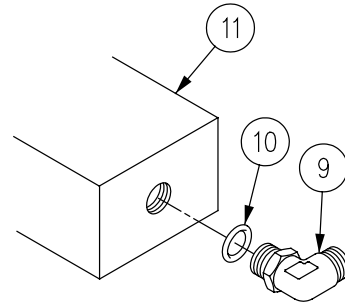

OLD CONFIGURATION

4. Install elbow (12) on transmission.

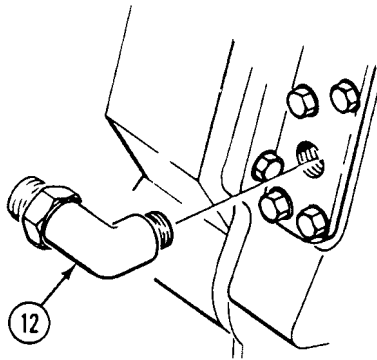

5. Install elbow (13) on transmission.

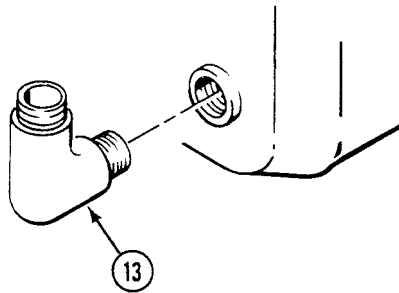

6. Install hose (1) on elbow (2).

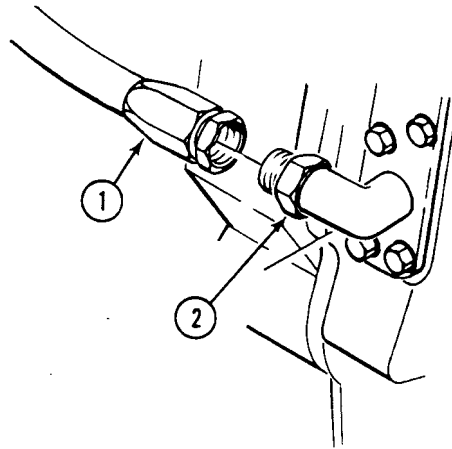

7. Install hose (3) on elbow (4).

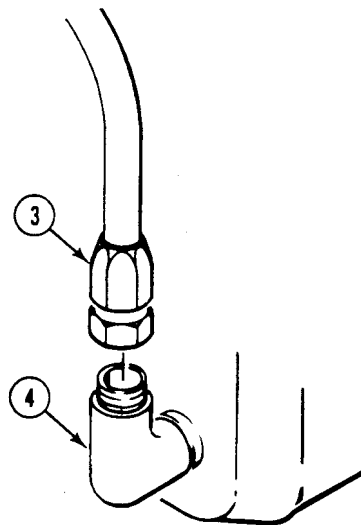

8. Install hose (3) on elbow (5).

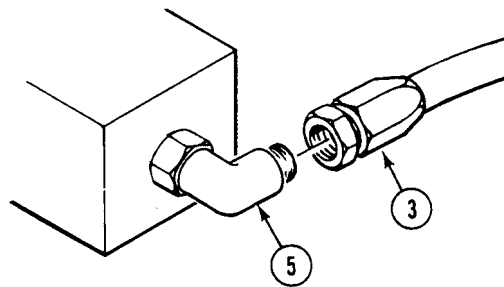

9. Install return hose (1) on elbow (6).

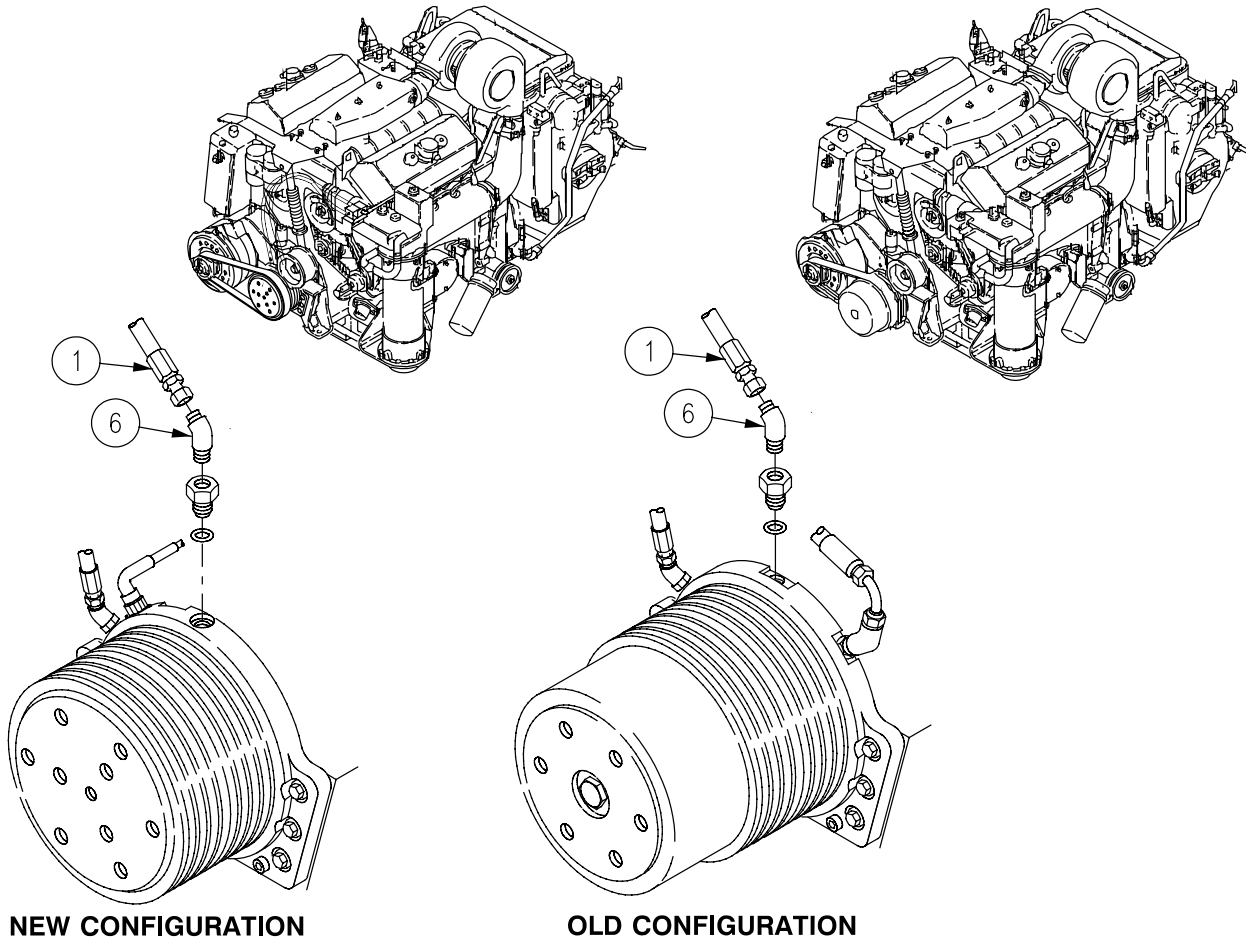

10. Install hose (1) on engine. Secure with screw (7), two washers (8), new locknut (9) and clamp (10).

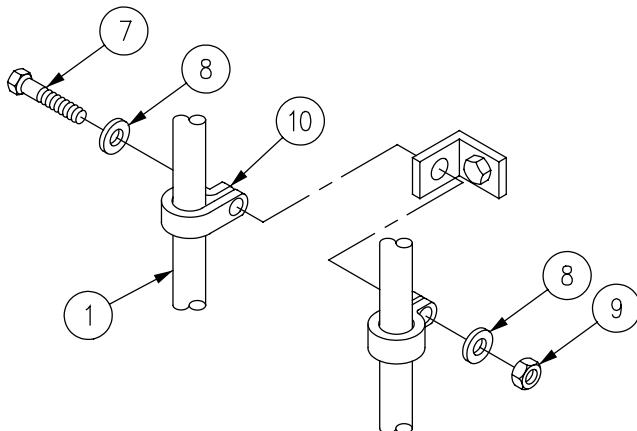

11. Secure hose (1) to two brackets (2) on transmission using two clamps (3), screws (4), four washers (5), and two nuts (6).

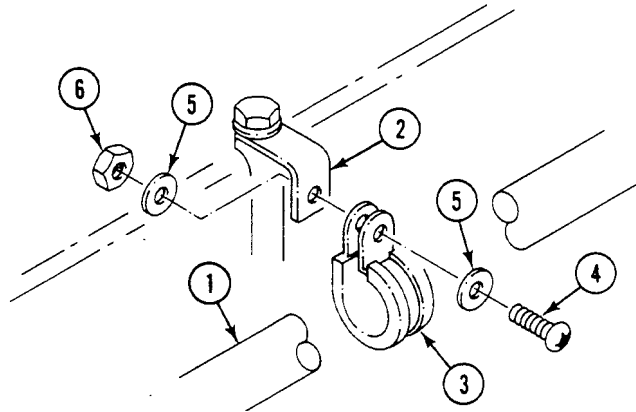
**FOLLOW-THROUGH STEPS**

1. Install power plant (WP 0156 00).
2. Fill transmission with oil (WP 0398 00).
3. Start engine and check for leaks (see your -10).
4. Stop engine (see your -10).

END OF TASK

REPLACE HOSE FROM VARIABLE SPEED FAN DRIVE OVERRIDE SWITCH TO VSFD DRIVE (NEW CONFIGURATION)

0251 01

THIS WORK PACKAGE COVERS:

Removal (page 0251 01-1).
Installation (page 0251 01-5).

INITIAL SETUP:

Maintenance Level

Unit

Tools and Special Tools

General Mechanic's Tool Kit (WP 0926 00, Item 65)

Materials/Parts

Packing, preformed (2)
Straps (2)

Personnel Required

Unit Mechanic

References

See your -10
Drawing 12474790

Equipment Condition

Engine stopped (see your -10)
Carrier blocked (see your -10)
Transmission oil supply and return hoses disconnected
(WP 0251 00)

REMOVAL

1. Remove straps (1) securing variable speed fan drive hoses together.
2. Remove hose (2) from elbow (3) on drive assembly (4).
3. Remove elbow (3) and packing (5) from drive assembly (4). Discard packing.
4. Remove hose (2) from elbow (6) on valve (7).
5. Remove elbow (6) and packing (8) from valve (7). Discard packing.

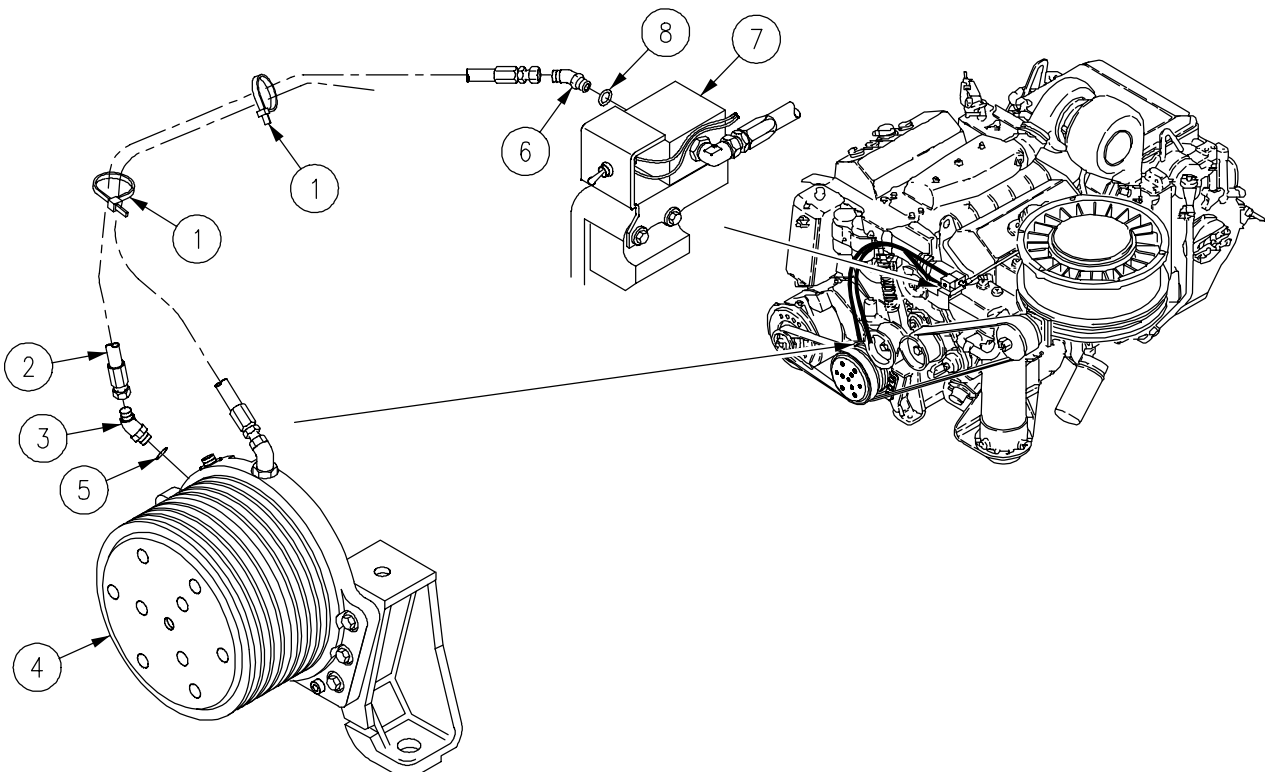

**REPLACE HOSE FROM VARIABLE SPEED FAN DRIVE OVERRIDE SWITCH
TO VSFD DRIVE (NEW CONFIGURATION) - Continued**

0251 01

INSTALLATION

1. Install new packing (8) and elbow (6) on valve (7).
2. Connect hose (2) to elbow (6) on valve (7).
3. Install new packing (5) and elbow (3) on drive assembly (4).
4. Connect hose (2) to elbow (3) on drive assembly (4).
5. Install straps (1) securing variable speed fan drive hoses together.

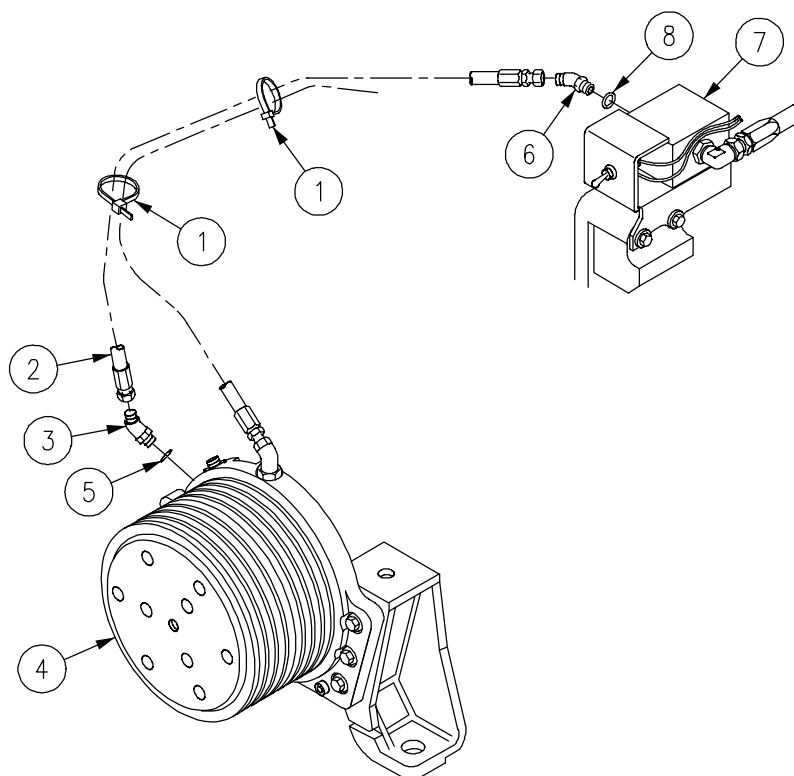
**FOLLOW-THROUGH STEPS**

1. Connect transmission oil supply and return hoses (WP 0251 00-1).
2. Start engine and check for leaks (see your-10).
3. Stop engine (see your-10).

END OF TASK

INDEX

<u>Subject</u>	<u>WP Sequence No.-Page No.</u>
5.0 KW Auxiliary Power Unit M577A3 and M1068A3 Replacement.....	0675 00-1
A	
A.C. Power Extension Box A7 (M1068A3) Replace.....	0815 00-1
A1 Power Control Enclosure Assembly M1068A3 Replacement.....	0826 00-1
A4 Power Entry Box Assembly M1068A3 Replacement.....	0832 00-1
AC Cable Assembly W252 M1068A3 Replacement.....	0857 00-1
AC Light Cable (W11) M1068A3 Replacement.....	0845 00-1
AC Power Extension Box A19 M1068A3 Replacement.....	0822 00-1
AC Power Extension Box A6 M1068A3 Replacement.....	0834 00-1
AC Power Extension Box A6 and DC Power Extension Box A9 and Mount M1068A3 Replacement.....	0834 00-1
AC Power Extension Cable (W7) M1068A3 Replacement.....	0842 00-1
AC Power Extension Cable (W8) (M1068A3) Replace.....	0843 00-1
Accelerator Linkage Adjust.....	0214 00-1
Accelerator Pedal Lower Replacement.....	0215 00-1

INDEX, cont'd

<u>Subject</u>	<u>WP Sequence No.-Page No.</u>
Accelerator Pedal Assembly	
Upper	
Replacement.....	0216 00-1
Access cover	
Battery box	
M577A3 and M1068A3	
Repair.....	0352 00-1
Fan drive pulley	
Removal/installation.....	0440 00-1
Hull front	
Replacement.....	0449 00-1
Power plant bottom	
Replacement.....	0450 00-1
Access Covers	
Fuel Tank	
M577A3 and M1068A3	
Replacement.....	0188 00-1
Access covers	
Fuel tank	
All except M577A3 and M1068A3	
Replacement.....	0187 00-1
Access door	
Radiator	
Replacement.....	0469 00-1
Turbine	
M58	
Replacement.....	0485 00-1
Access door gasket	
Turbine	
M58	
Replacement.....	0486 00-1
Access door hinges	
Turbine	
M58	
Replacement.....	0487 00-1
Access panel	
Driver's power plant	
Replacement.....	0441 00-1
Access Plate	
Adapter	
Smoke Generator (M1059A3)	
Replace.....	0766 00-1

INDEX, cont'd

<u>Subject</u>	<u>WP Sequence No.-Page No.</u>
Adapter	
Speedometer	
Replace.....	0860 00-1
Tachometer	
Replace.....	0863 00-1
Adjuster	
Track tension	
Replacement.....	0419 00-1
Admittance buzzer and switch	
M577A3 and M1068A3	
Replacement.....	0334 00-1
Air Box Heater	
IgnitionWire	
Replacement.....	0204 00-1
Wiring Harness	
Replacement.....	0205 00-1
Air Box Heater Lower Fuel Line	
Replacement.....	0206 00-1
Air Box Ignition Coil	
Replacement.....	0208 00-1
Air box pressure transducer	
Replacement.....	0327 00-1
Air Cleaner	
Elbow	
Replacement.....	0168 00-1
Filter Element	
Service.....	0167 00-1
Replacement.....	0168 00-1
Air cleaner	
Restriction indicator	
Replace.....	0171 00-1
Restriction indicator hose	
Replace.....	0172 00-1
Air Cleaner Assembly	
Replace	0169 00-1
Air Cleaner Retainer	
Repair	0170 00-1
Air Compressor	
Electrical Cable Assembly	
M1059A3	
Replacement.....	0758 00-1

INDEX, cont'd

<u>Subject</u>	<u>WP Sequence No.-Page No.</u>
Air Compressor Assembly (M1059A3 Only)	
Replace.....	0762 00-1
Air Hose	
Adapter Access Plate to Cover Assembly Smoke Generator (M1059A3)	
Replace.....	0768 00-1
Compressor Reservoir to Access Plate Smoke Generator (M1059A3)	
Replace.....	0767 00-1
Air intake	
Elbow	
Replace.....	0173 00-1
Air Intake and Exhaust Pipes	
Heater	
Replacement.....	0683 00-1
Air Intake elbow and hose	
Grill	
Replace.....	0174 00-1
Air Intake Pipes, Heater	
All Except M1064A3	
Replacement.....	0682 00-1
Air Purifier and Frame	
NBC	
M58	
Replacement.....	0914 00-1
Air purifier and frame	
M13	
M1068A3 only	
Replace.....	0779 00-1
Air Separator	
Coolant	
Replacement.....	0236 00-1
Air ventilator	
Rear compartment	
Replacement.....	0454 00-1
Alarm Kit, Automatic	
Chemical Agent	
M113A3	
Installation/Removal	0918 00-1

INDEX, cont'd

<u>Subject</u>	<u>WP Sequence No.-Page No.</u>
Ammunition Rack	
Horizontal	
M1064A3	
Replacement.....	0606 00-1
Ammunition rack	
Horizontal	
M1064A3	
Repair.....	0607 00-1
Vertical	
M1064A3	
Replacement.....	0608 00-1
Amplifier	
Intercom	
M58	
Replace.....	0888 00-1
AN/VAS-5 Driver's Night Vision Enhancer Sensor Set Assembly Adapter (DVE)	
M58	
Replacement.....	0866 05-1
AN/VAS-5 Driver's Vision Enhancer Stowage Bracket	
M58	
Replacement.....	0866 03-1
AN/VVS-2	
Driver's Night Vision Stowage	
All Except M58	
Replacement.....	0572 00-1
AN/VVS-2 driver's night vision guard	
Driver's Hatch	
All Except M58	
Replacement.....	0536 00-1
(AN/VVS-2) Driver's night vision mount	
All Except M58	
Replacement.....	0537 00-1
Anchor	
Torsion bar	
Replacement.....	0414 00-1
Antenna	
AS3916/VRC	
M58	
Replacement.....	0887 00-1
Guard	
Replacement.....	0575 00-1

INDEX, cont'd

<u>Subject</u>	<u>WP Sequence No.-Page No.</u>
Mast Bracket Assembly	
M1068A3	
Repair.....	0625 00-1
Replacement.....	0625 00-1
Support	
M58	
Replacement.....	0602 00-1
APIU Rack	
Mount and Bracket	
M1068A3	
Replacement.....	0813 00-1
Arm	
Road wheel support	
Replacement.....	0415 00-1
Arm assembly	
Idler wheel	
Replacement.....	0417 00-1
Armor	
Front	
M113A3	
Replacement.....	0749 00-1
Shields, Commander's Cupola	
M113A3 and M1064A3	
Replacement.....	0747 00-1
Smoke Generator (M1059A3)	
Replace.....	0771 00-1
Armor Kit	
M113A3	
Installation.....	0748 00-1
Mine	
M113A3	
Installation/Removal.....	0752 00-1
Armor plate	
Left front	
Replacement.....	0447 00-1
Right front	
Replacement.....	0448 00-1
AS3916/VRC Antenna	
M58	
Replacement.....	0887 00-1

INDEX, cont'd

<u>Subject</u>	<u>WP Sequence No.-Page No.</u>
Assembly	
M8A3/M14 Orifice connector	
M113A3, M1059A3, and M577A3 only	
Replace.....	0780 00-1
Auxiliary power (slave) receptacle	
M113A3, M1059A3, M1064A3, and M58 only	
Replacement.....	0263 00-1 ■
Auxiliary power (slave) receptacle ground lead	
M113A3, M1059A3, M1064A3, and M58	
Replacement.....	0379 00-1 ■
Auxiliary Power Unit	
5.0 KW	
M577A3 and M1068A3	
Replacement.....	0675 00-1
Auxiliary Power Unit Fuel Shutoff Valve	
M577A3 and M1068A3	
Replacement.....	0676 00-1
Auxiliary Power Unit Valve-to-bulkhead Fuel Supply Hoses	
M577A3 and M1068A3	
Replacement.....	0677 00-1
Auxiliary Tank	
Replacement.....	0230 00-1
Auxiliary tank fluid level detector	
Replacement.....	0329 00-1
Azimuth lock	
Commander's cupola	
M113A3, M1059A3, M58, and M1064A3	
Replacement.....	0489 00-1
B	
Back Assembly	
Driver's Seat	
Repair.....	0554 00-1
Replacement.....	0553 00-1
Balance Hose	
Replacement.....	0234 00-1
Base	
Smoke grenade launcher	
M113A3 and M1059A3 only	
Replacement.....	0455 00-1 ■
Base Extension	
Right Side	
M1068A3	
Replacement.....	0623 00-1

INDEX, cont'd

<u>Subject</u>	<u>WP Sequence No.-Page No.</u>
Base Extension Supports	
Right Side	
M1068A3	
Replacement.....	0624 00-1
Batteries and battery box	
M58	
Replacement.....	0348 00-1
Batteries and retainers	
M113A3 and M1059A3	
Replacement.....	0346 00-1
M577A3 and M1068A3	
Replacement.....	0347 00-1
Battery	
Box	
M577A3 and M1068A3	
Repair.....	0351 00-1
M1064A3	
Replacement.....	0349 00-1
Retainers	
M1064A3	
Replacement.....	0349 00-1
Battery box	
M113A3 and M1059A3	
Repair.....	0350 00-1
Battery box (right side)	
M1064A3	
Repair.....	0354 00-1
Battery box access cover	
M577A3 and M1068A3	
Repair.....	0352 00-1
Battery box hose	
Engine to	
Replacement.....	0714 00-1
Battery Box Insulation and Heat Exchanger	
Replacement.....	0718 00-1
Battery box vent fitting	
M58	
Replacement.....	0355 00-1
Battery drawer	
M1064A3	
Repair.....	0353 00-1

INDEX, cont'd

<u>Subject</u>	<u>WP Sequence No.-Page No.</u>
Battery Drawer Insulation and Heat Exchanger	
M1064A3	
Replacement.....	0719 00-1
Battery ground lead	
M577A3 and M1068A3	
Connect	0338 00-1
Disconnect.....	0338 00-1
Battery ground strap	
M113A3, M1059A3, M1064A3, and M58	
Connect	0337 00-1
Disconnect.....	0337 00-1
Battery leads and terminals	
M113A3 and M1059A3	
Replacement.....	0340 00-1
M577A3 and M1068A3	
Replacement.....	0341 00-1
M58	
Replacement.....	0345 00-1
Battery leads and terminals (left side)	
M1064A3	
Replacement.....	0343 00-1
Battery leads and terminals (right side)	
M1064A3	
Replacement.....	0344 00-1
Battery Plate to Battery Plate Hose	
Replacement.....	0722 00-1
Battery to master switch lead (circuit 6)	
M1064A3	
Replacement.....	0358 00-1
M113A3 and M1059A 3	
Replacement.....	0356 00-1
M577A3 and M1068A3	
Replacement.....	0357 00-1
Battery-to-radio Wiring harness	
(Left Side)	
M113A3 and M1059A3	
Replacement.....	0369 00-1
Battery-to-radio wiring harness (right side)	
M113A3	
Replacement.....	0370 00-1
Battery/generator indicator malfunctions	0051 00-1

INDEX, cont'd

<u>Subject</u>	<u>WP Sequence No.-Page No.</u>
Bearing	
Tow Start Control Assembly	
Replacement.....	0391 00-1
Bearings	
Idler wheel arm	
Replacement.....	0418 00-1
Road wheel support	
Replacement.....	0415 00-1
Belt	
Generator drive	
Adjustment.....	0252 00-1
Replacement.....	0253 00-1
Ventilating Fan Drive	
Adjustment.....	0242 00-1
Replacement.....	0243 00-1
Belts	
Coolant Pump	
Adjustment.....	0239 00-1
Coolant Pump Idler	
Replacement.....	0240 00-1
Personnel	
M113A3	
Replacement.....	0546 00-1
M577A3	
Replacement.....	0547 00-1
Personnel seat	
M1059A3	
Replacement.....	0549 00-1
M1064A3	
Replacement.....	0550 00-1
Bilge Pump	
Front	
Replace.....	0632 00-1
Pipes	
Front, Replace.....	0631 00-1
Rear	
Replacement.....	0635 00-1
Bilge pump circuit breakers	
Replacement.....	0275 00-1
Bilge Pump Pipes	
Rear Bilge	
Replacement.....	0634 00-1

INDEX, cont'd

<u>Subject</u>	<u>WP Sequence No.-Page No.</u>
Blackout Curtain	
M577A3 and M1068A3	
Replacement.....	0629 00-1
Blackout dome lights do not work	
M1068A3 only	0041 00-1
Blackout drive light doesn't work.....	0030 00-1
Blackout headlight	
Repair	0306 00-1
Replacement.....	0305 00-1
Blackout marker light	
Repair	0308 00-1
Replacement.....	0307 00-1
Blackout marker light(s) don't work	0034 00-1
Blank display diagnostic troubleshooting	
STE/ICE	0138 00-1
Blower switch	
M577A3 and M1068A3 only	
Replacement.....	0278 00-1
Bottom access cover	
Power plant	
Replacement.....	0450 00-1
Box	
Battery	
M113A3 and M1059A3	
Repair.....	0350 00-1
Heater Control	
Coolant Heater	
Repair.....	0737 00-1
Repalcement.....	0736 00-1
Personnel Heater Control	
Repair	0702 00-1
Replacement.....	0701 00-1
Box Assembly A5	
Tent Interface Panel	
M1068A3	
Replacement.....	0833 00-1
Bracket	
Chemical Alarm Refill Tray	
M113A3	
Replacement.....	0922 00-1
Coolant Heater and Pump	
Replacement.....	0732 00-1

INDEX, cont'd

<u>Subject</u>	<u>WP Sequence No.-Page No.</u>
Generator	
Replacement.....	0255 00-1
M13 Orifice	
M1068A3 only	
Replace.....	0781 00-1
Oil Can	
Replacement.....	0574 00-1
Parking brake	
Replacement.....	0331 00-1
Power Extension Box A18	
M1068A3	
Replacement.....	0836 00-1
Ramp	
M113A3, M577A3, and M1068A3	
Replacement.....	0516 00-1
Ramp Door Stop	
Replacement.....	0517 00-1
Roadside Data Panel Assembly A13	
M1068A3	
Replacement.....	0835 00-1
Spare Battery, Chemical Alarm	
M113A3	
Replace/Repair.....	0921 00-1
Transmission range controller	
Used with cable-activated steering lock	
Replacement.....	0387 00-1
Used with solenoid-activated steering lock	
Replacement.....	0386 00-1
Bracket,	
Mortar Base Stowage	
M1064A3	
Replacement.....	0615 00-1
Windshield Stowage	
M1064A3	
Replacement.....	0614 00-1
Brackets	
Rifle	
Replacement.....	0573 00-1
Brackets and Mounts	
Right Equipment Rack	
M1068A3	
Replacement.....	0814 00-1

INDEX, cont'd

<u>Subject</u>	<u>WP Sequence No.-Page No.</u>
Brake	
Parking	
Adjustment.....	0408 00-1
Brake adjustment	
Transmission	
Check	0406 00-1
Brake assembly	
Commander's cupola	
M113A3, M1059A3, M58, and M1064A3	
Replacement.....	0492 00-1
Brakes	
Transmission	
Adjust.....	0394 00-1
Breather Hose	
Ramp Cylinder	
All Except M1064A3	
Replacement.....	0666 00-1
M1064A3	
Replacement.....	0667 00-1
Bulkhead Connection Hose	
Fuel Pump to	
M113A3, M1059A3, and M58	
Replacement.....	0691 00-1
Bulkhead connection to Personnel Heater Tube	
M577A3 and M1068A3	
Replacement.....	0687 00-1
Bumper	
Driver's Hatch	
M113A3, M1059A3, M1064A3, and M58	
Replacement.....	0532 00-1
Buzzer and switch	
Admittance	
M577A3 and M1068A3	
Replacement.....	0334 00-1
Bypass plug	
Differential	
Replacement.....	0401 00-1
C	
Cable	
Adapter	
M1068A3	
Replacement.....	0849 00-1, 0850 00-1

INDEX, cont'd

<u>Subject</u>	<u>WP Sequence No.-Page No.</u>
Artillery Communication Inside	
M577A3	
Replacement.....	0746 00-1
Commander's Intercommunication Set	
M58	
Replacement.....	0893 00-1
Driver's Intercommunication Set	
M58	
Replacement.....	0892 00-1
Instrument panel special purpose	
Replacement.....	0290 00-1
Operator's Intercommunication Set	
M58	
Replacement.....	0894 00-1
Reel holder	
M1064A3	
Replacement.....	0603 00-1
Speedometer	
Repair.....	0861 00-1
Replace.....	0860 00-1
Service.....	0858 00-1
Tachometer	
Repair.....	0865 00-1
Replace.....	0864 00-1
Service.....	0858 00-1
W251	
M1068A3	
Replacement.....	0852 00-1
W252	
M1068A3	
Replacement.....	0857 00-1
W28	
M1068A3	
Replacement.....	0849 00-1
W29	
M1068A3	
Replacement.....	0850 00-1
W35	
M1068A3	
Replacement.....	0849 00-1
W38	
M1068A3	
Replacement.....	0850 00-1

INDEX, cont'd

<u>Subject</u>	<u>WP Sequence No.-Page No.</u>
W42	
M1068A3	
Replacement.....	0852 00-1
W43	
M1068A3	
Replacement.....	0852 00-1
Cable (W10)	
DC Power Extension	
M1068A3	
Replace.....	0844 00-1
Cable (W11)	
AC Light	
M1068A3	
Replacement.....	0845 00-1
Cable (W4)	
DC Battery	
M1068A3	
Replacement.....	0838 00-1
Cable (W40)	
Single Point LAN	
M1068A3	
Replacement.....	0851 00-1
Cable (W5)	
Inverter AC	
Replacement/Repair	0839 00-1
Cable (W6)	
Inverter DC	
M1068A3	
Replacement.....	0840 00-1
Cable (W7)	
AC Power Extension	
M1068A3	
Replacement.....	0842 00-1
Cable (W8)	
AC Power Extension (M1068A3)	
Replace.....	0843 00-1
Cable Assembly	
Control	
Tow Start	
Adjustment.....	0390 00-1
Smoke Generator Internal	
M1059A3	
Replacement.....	0760 00-1

INDEX, cont'd

<u>Subject</u>	<u>WP Sequence No.-Page No.</u>
Cable assembly	
Driver's night vision (DNV) (AN/VVS-2) power supply	
All Except M58	
Replacement.....	0368 00-1
Cable Assembly (W4/W6)	
M1068A3	
Repair	0841 00-1
Cable reel holder assembly	
M1064A3	
Repair	0604 00-1
Cable Tube	
External	
Replacement.....	0905 00-1
Cable W3	
Power Distribution	
M1068A3	
Replacement.....	0837 00-1
Cable-activated steering lock malfunctions.....	0077 00-1
Cables	
LAN A or B (W103/W104)	
M1068A3	
Replacement.....	0854 00-1
W124	
M1068A3	
Replacement.....	0855 00-1
W126	
M1068A3	
Replacement.....	0856 00-1
W45	
M1068A3	
Replacement.....	0853 00-1
Cables and switch assembly	
M14 NBC	
M1059A3	
Replacement.....	0799 00-1
Cap	
Muffler	
Replacement.....	0223 00-1
Cargo hatch cover	
M113A3 and M1059A3	
Replacement.....	0479 00-1

INDEX, cont'd

<u>Subject</u>	<u>WP Sequence No.-Page No.</u>
Cargo hatch hold-open hook and bumpers	
M113A3 and M1059A3	
Replacement.....	0474 00-1
Cargo hatch interior latch	
M113A3 and M1059A3	
Replacement.....	0475 00-1
Cargo hatch seals	
M113A3 and M1059A3	
Replacement.....	0478 00-1
Wheel assembly	
Drive sprocket	
Repair.....	0421 00-1
Carrier does not move in any shift lever position.....	0062 00-1
Carrier drifts or does not steer.....	0063 00-1
Carrier moves with transmission in SL.....	0061 00-1
Cascade Remote Harness	
M1068A3	
Replacement.....	0847 00-1
Catches and bumpers	
Mortar hatch exterior	
M1064A3	
Replacement.....	0480 00-1
Chain Assembly, Litter Kit	
M113A3	
Repair.....	0745 00-1
Chain Assembly, Litter Kit	
M113A3	
Replace.....	0744 00-1
Chemical Agent Automatic Alarm Kit	
Junction Box	
M113A3	
Repair.....	0920 00-1
M113A3	
Installation/Removal.....	0918 00-1
Junction Box	
Replacement.....	0919 00-1
Refill Tray Bracket	
M113A3	
Replacement.....	0922 00-1
Spare Battery	
M113A3	
Replace/Repair.....	0921 00-1

INDEX, cont'd

<u>Subject</u>	<u>WP Sequence No.-Page No.</u>
Wiring Harnesses, M43 Unit Interface	
M113A3	
Replacement.....	0923 00-1
Circuit breaker	
Dome light	
M577A3 and M1068A3	
Replacement.....	0316 00-1
Replacement.....	0280 00-1
Circuit breakers	
Bilge pump	
Replacement.....	0275 00-1
Rear utility receptacle	
M577A3 and M1068A3 only	
Replacement.....	0276 00-1
Clamps	
Tent	
M577A3	
Replacement.....	0627 00-1
Coil	
Air Box Ignition	
Replacement.....	0208 00-1
Combat filler cover and lock	
Replacement.....	0466 00-1
Combat lock	
Power plant door	
Replacement.....	0473 00-1
Commander's Cupola	
Armor Shields	
M113A3, M1059A3, and M1064A3	
Replacement.....	0747 00-1
Commander's cupola azimuth lock	
M113A3, M1059A3, M58, and M1064A3	
Replacement.....	0489 00-1
Commander's cupola brake assembly	
M113A3, M1059A3, M58, and M1064A3	
Replacement.....	0492 00-1
Commander's cupola cover	
M113A3, M1059A3, and M1064A3	
Replacement.....	0493 00-1
Commander's cupola cushioning pad and handle	
M113A3, M1059A3, M58, and M1064A3	
Replacement.....	0488 00-1

INDEX, cont'd

<u>Subject</u>	<u>WP Sequence No.-Page No.</u>
Commander's cupola hold-open hook and bumper M113A3, M1059A3, M58, and M1064A3 Replacement.....	0494 00-1
Commander's cupola interior latch M113A3, M1059A3, M58, and M1064A3 Replacement.....	0496 00-1
Commander's cupola machine gun mount M113A3, M1059A3, M58, and M1064A3 Repair.....	0498 00-1
	Replacement..... 0497 00-1
Commander's cupola machine gun mount stops M1059A3 Replacement.....	0499 00-1
Commander's cupola safety pin stowage block M113A3, M1059A3, M58, and M1064A3 Replacement.....	0495 00-1
Commander's cupola vision block locks and seals M1064A3 Replacement.....	0491 00-1
	M113A3 and M1059A3, M58 Replacement..... 0490 00-1
Commander's Display Mounting Bracket (DVE) M58 Replacement.....	0866 06-1
Commander's hatch cover M577A3 and M1068A3 Replacement.....	0503 00-1
Commander's hatch cushioning pad and handle M577A3 and M1068A3 Replacement.....	0500 00-1
Commander's hatch hook and bumper M577A3 and M1068A3 Replacement.....	0501 00-1
Commander's hatch interior latch M577A3 and M1068A3 Replacement.....	0502 00-1
Commander's Intercommunication Set Cable M58 Replacement.....	0893 00-1
Commander's Jump Seat M113A3 Replacement.....	0563 00-1

INDEX, cont'd

<u>Subject</u>	<u>WP Sequence No.-Page No.</u>
Commander's platform	
M113A3, M1059A3, M1064A3, and M58	
Replacement/repair.....	0559 00-1
Commander's Platform and Post	
M577A3 and M1068A3	
Replacement/Repair	0564 00-1
Commander's Seat	
M1068A3	
Replacement/repair.....	0566 00-1
Commander's seat	
M113A3, M1059A3, M1064A3, and M58	
Repair	0562 00-1
Commander's Seat and Post	
M1064A3	
Replacement.....	0561 00-1
M113A3, M1059A3, and M58	
Replacement.....	0560 00-1
Commander's Vision Enhancer (DVE) display does not work.....	0116 02-1
Communication Box A11, External	
Lid and Latches	
Replace (M1068A3).....	0818 00-1
Communication Box A11, External (M1068A3)	
Replace	0817 00-1
Communication Cabling Diagram	
M58	0884 00-1
Confidence test diagnostic troubleshooting	
STE/ICE	0139 00-1
Connector assembly	
M13 Orifice	
M1068A3 only	
Replace.....	0781 00-1
Connector assembly, bracket, and quick coupling half	
M13 Orifice	
M1068A3 only	
Replace.....	0781 00-1
Control Assembly and Bearing	
Tow Start	
Replacement.....	0391 00-1
Control assembly, bracket, links, and pins (cable-activated lock)	
Push-pull	
Replacement.....	0429 00-1

INDEX, cont'd

<u>Subject</u>	<u>WP Sequence No.-Page No.</u>
Control Box	
Coolant Heater	
Repair	0737 00-1
Replacement	0736 00-1
Personnel Heater	
Repair	0702 00-1
Replacement	0701 00-1
Control Cable Assembly	
Fuel Cutoff	
Replacement	0220 00-1
Hand throttle	
Replacement	0219 00-1
Control cable assembly	
Parking brake	
Replacement	0411 00-1
Control lever assembly	
Parking brake	
Replacement	0412 00-1
Control linkage	
Service brake	
Adjustment	0407 00-1
Replacement	0410 00-1
Trim vane	
Repair	0461 00-1
Control Valve	
Fire Extinguisher	
Replacement	0904 00-1
Control Valve (with Internal Relief Valve)	
Ramp	
Replacement	0661 00-1
Controller	
Glow plug	
Replacement	0210 00-1
Controller Mounting Bracket	
Glow Plug	
Replacement	0212 00-1
Coolant Air Separator	
Replacement	0236 00-1
Coolant Heater	
Control Box	
Repair	0737 00-1
Replacement	0736 00-1

INDEX, cont'd

<u>Subject</u>	<u>WP Sequence No.-Page No.</u>
Coolant	
Heater to Engine Elbow, Replace	0715 00-1
Exhaust Elbow and Pipes	
Replacement	0724 00-1
Fuel Pump	
Replacement	0723 00-1
Fuel Shutoff Valve	
Replacement	0720 00-1
Hoes	
Fuel	
Inlet, Replace	0712 00-1
Hoses	
Coolant	
Pump to Battery Box, Replace	0713 00-1
Fuel	
Filter Valve, Replace	0716 00-1
Pump, Replace	0711 00-1
Pump	
Replacement	0731 00-1
Replace	0728 00-1, 0729 00-1
Wiring Harness	
Replacement	0735 00-1
Coolant Heater and Pump	
Bracket	
Replacement	0732 00-1
Coolant Heater Fuel Filter	
Service	0708 00-1
Coolant Heater Fuel Pump	
Service	0709 00-1
Coolant heater malfunctions	0089 00-1
Coolant Heater to Surge Tank Hose	
Replacement	0725 00-1
Coolant Hose and Tube	
Upper	
Replacement	0232 00-1
Coolant Pump Belts	
Adjustment	0239 00-1
Coolant temp indicator malfunctions	0053 00-1
Coolant temperature transmitter	
Replacement	0321 00-1
Cooling system	
Drain and fill	0227 00-1

INDEX, cont'd

<u>Subject</u>	<u>WP Sequence No.-Page No.</u>
Cover	
Antenna	
Replacement.....	0576 00-1
Battery box access	
M577A3 and M1068A3	
Repair.....	0352 00-1
Cargo hatch	
M113A3 and M1059A3	
Replacement.....	0479 00-1
Commander's cupola	
M113A3, M1059A3, and M1064A3	
Replacement.....	0493 00-1
Commander's hatch	
M577A3 and M1068A3	
Replacement.....	0503 00-1
Driver's Hatch	
Replacement.....	0531 00-1
Fan drive pulley access	
Removal/installation.....	0440 00-1
Thermostat	
Replacement.....	0237 00-1
Tow Start Control Assembly	
Replacement.....	0392 00-1
Covers	
Mortar hatch	
Cushioning Pad	
Driver's Hatch	
Replacement.....	0530 00-1
Cushioning pad and handle	
Commander's cupola	
M113A3, M1059A3, M58, and M1064A3	
Replacement.....	0488 00-1
Commander's hatch	
M577A3 and M1068A3	
Replacement.....	0500 00-1
Cushions	
Personnel	
M113A3	
Replacement.....	0546 00-1
M577A3	
Replacement.....	0547 00-1

INDEX, cont'd

<u>Subject</u>	<u>WP Sequence No.-Page No.</u>
Personnel Seat	
M1059A3	
Replacement.....	0549 00-1
M1064A3	
Replacement.....	0550 00-1
Cylinder	
Fire Extinguisher	
Discharge Tubes	
Replacement.....	0899 00-1
Ramp	
Replacement.....	0656 00-1
Cylinder, Turbine	
Fire Extinguisher Discharge Tubes	
M58	
Replacement.....	0900 00-1
D	
Data Panel Assembly	
A13 Roadside	
M1068A3	
Replacement.....	0835 00-1
Data Panel Assembly (M1068A3)	
A12, Curbside	
Replace.....	0819 00-1
Data Plates, Stencils, Markers, and Decals	
Replacement.....	0654 00-1
Dataplates, Decals, and Markers	
All Models.....	0644 00-1
M1059A3	0651 00-1
M1064A3	0652 00-1
M113A3, M1059A3	0647 00-1
M113A3, M1059A3, M58	0646 00-1
M113A3, M1059A3	0645 00-1
M577A3, M1068A3 Only	0648 00-1
M58	0653 00-1
DC Battery Cable (W4)	
M1068A3	
Replacement.....	0838 00-1
DC Power Extension Box A9	
M1068A3	
Replacement.....	0834 00-1
DC Power Extension Cable (W10)	
M1068A3	
Replacement.....	0844 00-1

INDEX, cont'd

<u>Subject</u>	<u>WP Sequence No.-Page No.</u>
DCA battery voltage diagnostic troubleshooting	0141 00-1
DCA current shunt diagnostic troubleshooting	0142 00-1
Detector	
Auxiliary tank fluid level	
Replacement	0329 00-1
Diagram	
Communication Cabling	
M58	0884 00-1
Differential Pressure Switch	
Fuel Filter	
Replacement	0328 00-1
Differential pressure switch	
Replacement	0401 00-1
Dipstick	
Transmission oil level filler tube, and adapter	
X200-4	
Replacement	0395 00-1
X200-4A	
Replacement	0396 00-1
Discharge Tubes	
Cylinder	
Replacement	0899 00-1
Cylinder, Turbine	
M58	
Replacement	0900 00-1
STE/ICE	
M1064A3	
Replacement	0877 00-1
M113A3 and M1059A3	
Replacement	0874 00-1
M577A3 and M1068A3	
Replacement	0875 00-1
Distribution box	
M113A3, M1059A3, M1064A3, and M58	
Replacement	0269 00-1
M113A3, M1059A3, M1064A3, and M58 only	
Repair	0270 00-1
M577A3 and M1068A3 only	
Replacement	0271 00-1
Dome blackout light bypass switch	
M577A3 and M1068A3	
Replacement	0317 00-1

INDEX, cont'd

<u>Subject</u>	<u>WP Sequence No.-Page No.</u>
Dome light	
All Except M577A3 and M1068A3	
Repair	0310 00-1
Replacement	0309 00-1
M577A3 and M1068A3	
Repair	0312 00-1
Replacement	0311 00-1
Dome light and mount	
M577A3 and M1068A3	
Repair	0312 00-1
Dome light circuit breaker	
M577A3 and M1068A3	
Replacement	0316 00-1
Dome light lens	
All Except M577A3 and M1068A3	
Replacement	0313 00-1
Dome light malfunction	
M577A3 only	0040 00-1
Dome light switch	
Front	
M577A3 and M1068A3	
Replacement	0314 00-1
Rear	
M577A3 and M1068A3	
Replacement	0315 00-1
Dome light(s) do not work	0039 00-1
Door	
Power plant	
All except M113A3	
Replacement	0471 00-1
M113A3	
Replacement	0470 00-1
Repair	0472 00-1
Door combat lock	
Power plant	
Replacement	0473 00-1
Drain Check Valve and tubes	
Left Air Box	
Replace	0159 00-1
Drain Cock and Hose	
Replacement	0235 00-1

INDEX, cont'd

<u>Subject</u>	<u>WP Sequence No.-Page No.</u>
Drain plug	
Hull	
Replacement.....	0451 00-1
Drain plugs	
Final drive hull	
Replacement.....	0452 00-1
Fuel tank	
All except M577A3 and M1068A3	
Replacement.....	0187 00-1
Ramp	
Replacement.....	0515 00-1
Drawer	
Battery	
M1064A3	
Repair.....	0353 00-1
Drive Belt	
Ventilating Fan	
Adjustment.....	0242 00-1
Replacement.....	0243 00-1
Drive belt	
Generator	
Replacement.....	0253 00-1
Drive Pulley	
Ventilating Fan	
Replacement.....	0244 00-1
Drive shaft and bearing housing	
Fan	
Replacement.....	0248 00-1
Drive sprocket and wheel assembly	
Replacement.....	0420 00-1
Drive sprocket wheel assembly	
Drive sprocket	
Repair.....	0420 01-1, 0421 00-1
Driver's compartment floor plates	
Replacement.....	0453 00-1
Driver's Display Mounting Bracket (DVE)	
M58	
Replacement.....	0866 02-1
Driver's footrest	
Replacement.....	0558 00-1

INDEX, cont'd

<u>Subject</u>	<u>WP Sequence No.-Page No.</u>
Driver's Hatch	
Bumper	
M113A3, M1059A3, M1064A3, and M58	
Replacement.....	0532 00-1
Cushioning Pad	
Replacement.....	0530 00-1
Exterior Lock	
Replacement.....	0531 00-1
Hold-open Hook	
M113A3, M1059A3, M1064A3, and M58	
Replacement.....	0532 00-1
Driver's hatch night vision mount	
M58	
Replacement.....	0537 01-1
Driver's Intercommunication Set	
Cable	
M58	
Replacement.....	0892 00-1
Driver's night vision (DNV) (AN/VVS-2) power supply cable assembly	
All Except M58	
Replacement.....	0368 00-1
Driver's night vision guard (AN/VVS-2)	
Driver's Hatch	
All Except M58	
Replacement.....	0536 00-1
Driver's night vision mount	
AN/VVS-2	
All Except M58	
Replacement.....	0537 00-1
Driver's night vision mount (AN/VVS-2)	
All Except M58	
Replacement.....	0537 00-1
Driver's Night Vision Stowage	
AN/VVS-2	
All Except M58	
Replacement.....	0572 00-1
Driver's power plant access panel	
Replacement.....	0441 00-1
Driver's Seat	
Repair.....	0552 00-1
Driver's seat assembly	
Replacement.....	0551 00-1

INDEX, cont'd

<u>Subject</u>	<u>WP Sequence No.-Page No.</u>
Driver's seat back assembly	
Repair	0554 00-1
Replacement	0553 00-1
Driver's seat impact absorber	
Replacement	0555 00-1
Driver's seat post assembly	
Repair	0557 00-1
Replacement	0556 00-1
Driver's Vision Enhancer (DVE) AN/VAS-5 Power Supply Cable M58	
Replacement	0866 04-1
Driver's Vision Enhancer (DVE) display does not work	0116 01-1
Driver's windshield	
Replacement	0739 00-1
towage bag, straps, and decal	
Replacement	0740 00-1
DVE Sensor Set Assembly Power Cable M58	
Replacement	0866 01-1
E	
Elbow	
Air intake	
Replace	0173 00-1
Coolant Heater Exhaust	
Replacement	0724 00-1
Electrical Cable Assembly	
Air Compressor	
M1059A3	
Replacement	0758 00-1
Fog Oil Pump	
M1059A3	
Replacement	0759 00-1
Element	
Filter	
Air Cleaner	
Service	0167 00-1
Enclosure	
Generator set	
M577A3 and M1068A3	
Replacement	0674 00-1

INDEX, cont'd

<u>Subject</u>	<u>WP Sequence No.-Page No.</u>
Enclosure Assembly A1	
Power Control	
M1068A3	
Replacement.....	0826 00-1
Engine	
Adapter, Tachometer	
Replace.....	0863 00-1
Block Fitting and Hardware	
Replacement.....	0717 00-1
Exhaust elbows	
Left/right, replace.....	0225 00-1
Fuel return hose	
Replacement.....	0201 00-1
Fuel supply hose	
Replacement.....	0200 00-1
Lifting bracket, replace.....	0161 00-1
Oil filler cap, replace.....	0162 00-1
Oil sampling valve and hose, replace.....	0163 00-1
Engine Coolant Heater System	
Drain and Fill.....	0710 00-1
Engine coolant low level indicator malfunctions.....	0058 00-1
Engine Coolant Pump	
Replacement.....	0241 00-1
Engine cranks but will not start.....	0021 00-1
Engine cranks but won't start below 40 degrees (air box heater is used).....	0022 00-1
Engine cranks but won't start below 40 degrees F (glow plugs are used).....	0023 00-1
Engine cranks slowly.....	0020 00-1
Engine does not crank.....	0016 00-1
Engine does not start (cold weather only).....	0017 00-1
Engine exhaust elbows and double flex joint	
Replacement.....	0221 00-1
Engine fuel pump	
Replacement.....	0166 00-1
Engine Mounts	
Replace.....	0158 00-1
Engine oil low pressure indicator comes on.....	0026 00-1
Engine oil low pressure indicator malfunctions.....	0055 00-1
Engine oil low pressure transmitter and hardware	
Replacement.....	0320 00-1
Engine overcools.....	0015 00-1
Engine overheats (Old VSFD Configuration).....	0014 00-1
Engine overheats (New VSFD Configuration).....	0014 01-1
Engine runs rough, stalls, or doesn't put out full power.....	0024 00-1

INDEX, cont'd

<u>Subject</u>	<u>WP Sequence No.-Page No.</u>
Engine start switch	
Replacement	0284 00-1
Engine to battery box hose	
Replacement	0714 00-1
Engine wiring harness	
Replacement	0359 00-1
Equipment Description	0002 00-1
Location and Description of Major Components	0002 00-1
Evacuator valve and connector	
Exhaust	
Replace	0175 00-1
Exhaust	
Evacuator valve and connector	
Replace	0175 00-1
Exhaust elbows and double flex joint	
Engine	
Replacement	0221 00-1
Exhaust Joint, Double Flex, Repair	0222 00-1
Exhaust muffler and bracket	
Replace	0224 00-1
Exhaust Pipe Heat Shield, Turbo, Left/Right, Replace	0226 00-1
Exhaust Pipes, Heater	
All Except M1064A3	
Replacement	0682 00-1
Expendable/Durable Supplies and Materials List	0928 00-1
Extender Assembly	
Tow Pintle	
M113A3	
Repair	0811 02-1
Extender Kit	
Tow Pintle	
M113A3	
Installation	0811 01-1
Extension	
Muffler	
Replacement	0223 00-1
Engine overheats (New VSFD Configuration)	0014 01-1
Extension Box A7	
AC Power	
Replace	0815 00-1

INDEX, cont'd

<u>Subject</u>	<u>WP Sequence No.-Page No.</u>
Exterior catches and bumpers	
Mortar hatch	
M1064A3	
Replacement.....	0480 00-1
Exterior Lock	
Driver's Hatch	
Replacement.....	0531 00-1
External Cable Tube	
Replacement.....	0905 00-1
External Handle	
Fire Extinguisher	
Replacement.....	0904 00-1
External Handle Shield	
M1064A3	
Replacement.....	0903 00-1
M113A3 and M1059A3	
Replacement.....	0901 00-1
M577A3 and M1068A3	
Replacement.....	0902 00-1
Extinguisher, Fire	
Cylinder and Mount	
Replacement.....	0898 00-1
F	
Fan	
Variable Speed Drive	0249 00-1
Fan	
Variable Speed Drive	
Fan Drive Assembly.....	0249 01-1
Fan	
Variable Speed Drive	
Controller	0250 01-1
Fan	
Ventilation	
M577A3 and M1068A3	
Replacement.....	0383 00-1
Fan and generator variable speed drive	
Replacement.....	0249 00-1
Fan drive pulley access cover	
Removal/installation	0440 00-1
Fan drive shaft and bearing housing	
Replacement.....	0248 00-1

INDEX, cont'd

<u>Subject</u>	<u>WP Sequence No.-Page No.</u>
Field pressure switch	
Generator	
Replacement.....	0323 00-1
Filler Cap	
Strainer Parts	
All Except M577A3 and M1068A3	
Replacement.....	0184 00-1
M577A3 and M1068A3	
Replacement.....	0185 00-1
Filler Cover and Lock	
Fuel Tank	
All Except M577A3 and M1068A3	
Replacement.....	0182 00-1
Filler Flange	
Fuel Tank	
M577A3 and M1068A3	
Replacement.....	0189 00-1
Filler tube	
Dipstick, transmission oil level	
X200-4	
Replacement.....	0395 00-1
X200-4A	
Replacement.....	0396 00-1
Filler tube and dipstick	
Final drive	
Replacement.....	0402 00-1
Filler, fuel and strainer parts	
M577A3 and M1068A3	
Replacement.....	0186 00-1
Filter	
Fuel	
Replacement.....	0726 00-1
Filter Element	
Transmission oil	
Replacement.....	0398 00-1
Filter Fuel Supply Hoses	
M113A3, M1059A3, and M58	
Replacement.....	0685 00-1
Final drive	
Replacement.....	0403 00-1
Final drive differential oil seal	
Replacement.....	0404 00-1

INDEX, cont'd

<u>Subject</u>	<u>WP Sequence No.-Page No.</u>
Final drive filler tube and dipstick	
Replacement	0402 00-1
Final drive hull drain plugs	
Replacement	0452 00-1
Fire Extinguisher	
Cylinder and Mount	
Replacement	0898 00-1
Fire Extinguisher	
Control Valve	
Replacement	0904 00-1
External Handle	
Replacement	0904 00-1
M1059A3	
Replacement	0896 00-1
Fittings	
Coolant Heater Fuel Inlet	
Replace	0712 00-1
Fuel Return	
M1064A3	
Replacement	0197 00-1
M113A3, M1059A3, and M58	
Replacement	0195 00-1
M577A3 and M1068A3	
Replacement	0196 00-1
Fuel Vent	
M577A3 and M1068A3	
Replacement	0198 00-1
Personnel heater	
M577A3 and M1068A3	
Replacement	0700 00-1
Ramp Control Valve (with Internal Relief Valve)	
Replacement	0661 00-1
Flame Detector Switch	
Adjust	0727 00-1
Coolant Heater	
Replacement	0734 00-1
Flat pulleys and bearings	
Replacement	0245 00-1
Floor Plates	
M1059A3	
Replacement	0542 00-1
M1064A3	
Replacement	0543 00-1

INDEX, cont'd

<u>Subject</u>	<u>WP Sequence No.-Page No.</u>
M1068A3	
Replacement.....	0544 00-1
M113A3 and M577A3	
Replacement.....	0539 00-1
M58	
Replacement.....	0545 00-1
Floor plates	
Driver's compartment	
Replacement.....	0453 00-1
Fluid level detector	
Auxiliary tank	
Replacement.....	0329 00-1
Fluorescent Light Assemblies	
M1068A3	
Replacement.....	0825 00-1
Fluorescent lights do not operate	
M1068A3 only	0102 00-1
Fog Oil Pump	
Electrical Cable Assembly	
M1059A3	
Replacement.....	0759 00-1
Fog Oil Pump Assembly	
(M1059A3 Only)	
Replace.....	0763 00-1
Fog Oil Quick Disconnect to Adapter Access Plate Hose (M1059A3), Cover Assembly	
Replace.....	0770 00-1
Fog Oil Tank (M1059A3)	
Hose	
Quick Disconnect to Adapter Access Plate	
Replace.....	0769 00-1
Fog Oil Tank Module	
M1059A3	
Replacement.....	0753 00-1
Footrest	
Driver's	
Replacement.....	0558 00-1
Forward spall liner and bracket	
M113A3	
Replacement.....	0507 00-1
Forward Table, Right	
M577A3	
Replacement.....	0581 00-1

INDEX, cont'd

<u>Subject</u>	<u>WP Sequence No.-Page No.</u>
Forward upper right and left side spill liners	
M113A3	
Replacement.....	0508 00-1
Frame	
Blackout Curtain	
M577A3 and M1068A3	
Replacement.....	0629 00-1
Front access cover	
Hull	
Replacement.....	0449 00-1
Front and/or rear bilge pump(s) and/or lights don't work.....	0080 00-1
Front Armor	
M113A3	
Replacement.....	0749 00-1
Front armor plate	
Left	
Replacement.....	0447 00-1
Right	
Replacement.....	0448 00-1
Front Bilge Pump	
Replace.....	0632 00-1
Strainer	
Replace.....	0632 00-1
Front Bilge Valve	
Replace.....	0633 00-1
Front dome light switch	
M577A3 and M1068A3	
Replacement.....	0314 00-1
Fuel Shutoff Valve	
Coolant Heater	
Replacement.....	0720 00-1
Fuel Can Lid Assembly	
Smoke Generator (M1059A3)	
Replace.....	0764 00-1
Fuel cap vent and filter screen, clean.....	0176 00-1
Fuel Control Linkage	
Replacement.....	0217 00-1
Fuel Control Shaft	
Replacement.....	0217 00-1
Fuel Cutoff Control Cable Assembly	
Replacement.....	0220 00-1
Fuel Filters and Brackets	
Primary and Secondary.....	0203 00-1

INDEX, cont'd

<u>Subject</u>	<u>WP Sequence No.-Page No.</u>
Fuel Filter	
Coolant Heater	
Service.....	0708 00-1
Replacement.....	0726 00-1
Fuel filter	
Personnel heater	
M577A3 and M1068A3	
Replacement.....	0700 00-1
Fuel Filter Differential Pressure Switch	
Replacement.....	0328 00-1
Fuel Filter Elements	
Primary and Secondary	
Replacement.....	0202 00-1
Fuel filter, hose, tube, and fittings	
Personnel heater	
M577A3 and M1068A3	
Replacement.....	0700 00-1
Fuel filter, hoses, and fittings	
Personnel heater	
M1064A3	
Replacement.....	0688 00-1
Fuel Filters and Brackets	
Primary and Secondary	
Replacement.....	0203 00-1
Fuel level indicator malfunctions .	0049 00-1
Fuel Line	
Lower	
Air Box Heater	
Replacement.....	0206 00-1
Fuel Lines	
Air From Personnel Heater	
Bleed	0679 00-1
Fuel Lines and Guards	
Smoke Generator (M1059A3)	
Replace.....	0765 00-1
Fuel Pump	
Coolant Heater	
Replacement.....	0723 00-1
Service.....	0709 00-1
Personnel Heater	
M113A3, M1059A3, and M58	
Replacement.....	0695 00-1

INDEX, cont'd

<u>Subject</u>	<u>WP Sequence No.-Page No.</u>
Fuel pump	
Engine	
Replacement.....	0166 00-1
Fuel Pump Hose	
Coolant Heater	
Replace.....	0711 00-1
Fuel quantity transmitter	
All except M577A3 and M1068A3	
Replacement.....	0190 00-1
M577A3 and M1068A3	
Replacement.....	0191 00-1
Fuel return hoses	
Engine	
Replacement.....	0201 00-1
M1064A3	
Replacement.....	0197 00-1
M 113A3, M1059A3, and M58	
Replacement.....	0195 00-1
M577A3 and M1068A3	
Replacement.....	0196 00-1
Fuel return pressure transducer	
Replacement.....	0325 00-1
Fuel select switch to gauge lead	
All Except M577A3 and M1068A3	
Replacement.....	0281 00-1
Fuel selector switch	
M577A3 and M1068A3 only	
Replacement.....	0277 00-1
Fuel Shut-off Valve assembly	
M113A3, M1059A3, and M58	
Replacement.....	0684 00-1
Fuel Shutoff Valve	
Auxiliary Power Unit	
M577A3 and M1068A3	
Replacement.....	0676 00-1
Fuel Supply	
Hoses, Tubes, and Fittings	
M1064A3	
Replacement.....	0194 00-1
M113A3, M1059A3, and M58	
Replacement.....	0192 00-1

INDEX, cont'd

<u>Subject</u>	<u>WP Sequence No.-Page No.</u>
Fuel supply	
Hoses, tubes, and fittings	
M577A3 and M1068A3	
Replacement.....	0193 00-1
Fuel Supply Hoses	
Auxiliary Power Unit Valve-to-bulkhead	
M577A3 and M1068A3	
Replacement.....	0677 00-1
Fuel supply hoses	
Auxiliary power unit bulkhead-to-hull	
M577A3 and M1068A3	
Replacement.....	0678 00-1
Engine	
Replacement.....	0200 00-1
Fuel supply pressure transducer	
Replacement.....	0324 00-1
Fuel Tank	
Filler Cover and Lock	
All Except M577A3 and M1068A3	
Replacement.....	0182 00-1
Filler Flange	
M577A3 and M1068A3	
Replacement.....	0189 00-1
Fuel tank access covers	
M577A3 and M1068A3	
Replacement.....	0188 00-1
Fuel tank drain plugs	
M577A3 and M1068A3	
Replacement.....	0187 00-1
Fuel tank filler	
Cover and lock	
M577A3 and M1068A3	
Replacement.....	0183 00-1
Fuel Tank to Fuel Pump Hose	
M577A3 and M1068A3	
Replacement.....	0690 00-1
Fuel Tanks	
Drain	
M577A3 and M1068A3	0178 00-1

INDEX, cont'd

<u>Subject</u>	<u>WP Sequence No.-Page No.</u>
Fuel tanks	
All except M577A3 and M1068A3, replace	0179 00-1
Drain	
All except M577A3 and M1068A3.....	0177 00-1
M577A3 and M1068A3	
Replacement.....	0180 00-1
Temporary repair (M577A3 and M1068A3).....	0181 00-1
Fuel Tube	
Personnel Heater	
All Except M1064A3	
Replacement.....	0686 00-1
Fuel Valve	
Mounting Blocks	
All Except M577A3 and M1068A3	
Replacement.....	0199 00-1
Fuel Vent Hoses, Tubes, and Fittings	
M577A3 and M1068A3	
Replacement.....	0198 00-1
G	
Gasket	
Adapter Access Plate	
Smoke Generator (M1059A3)	
Replace.....	0766 00-1
Turbine access door	
M58	
Replacement.....	0486 00-1
Gauges	
Instrument panel	
Replacement.....	0285 00-1
General Information	0001 00-1
Generator	
Drive belt	
Replacement.....	0253 00-1
Replacement.....	0255 00-1
Turnbuckle parts	
Replacement.....	0254 00-1
Generator	
Variable Speed Drive	0249 00-1
Generator drive belt	
Adjustment	0252 00-1
Generator field pressure switch	
Replacement.....	0323 00-1
Generator malfunctions as indicated by battery/generator indicator.....	0025 00-1

INDEX, cont'd

<u>Subject</u>	<u>WP Sequence No.-Page No.</u>
Generator set	
Enclosure	
M577A3 and M1068A3	
Replacement.....	0674 00-1
Glow Plug	
Controller Mounting Bracket	
Replacement.....	0212 00-1
Glow Plug Cable Assembly	
Smoke Generator (M1059A3)	
Replace.....	0772 00-1
Glow plug controller	
Replacement.....	0210 00-1
Glow plug harness	
Replacement.....	0209 00-1
Glow Plug Power Harness	
Replacement.....	0211 00-1
Glow plugs	
Replacement.....	0209 00-1
Governor assembly	
Replacement.....	0397 00-1
Grenade Stowage box	
M1064A3	
Replacement.....	0610 00-1
Grill	
Air Intake elbow and hose	
Replace.....	0174 00-1
Grill screen	
Power plant	
Replacement.....	0468 00-1
Grill support arm	
Power plant	
Replacement.....	0467 00-1
Grille	
Power plant	
Raise and lower.....	0464 00-1
Removal/installation.....	0465 00-1
Ground lead	
Auxiliary power (slave) receptacle	
M113A3, M1059A3, M1064A3, and M58	
Replacement.....	0379 00-1

INDEX, cont'd

<u>Subject</u>	<u>WP Sequence No.-Page No.</u>
Battery	
M577A3 and M1068A3	
Connect	0338 00-1
Disconnect	0338 00-1
Ground Strap (W12)	
M1068A3	
Replacement	0846 00-1
Guard	
Antenna	
Replacement	0575 00-1
Driver's Hatch Night Vision	
M58	
Replacement	0536 01-1
Headlight	
Replacement	0446 00-1
Smoke grenade launcher	
M113A3 and M1059A3 only	
Replacement	0455 00-1
H	
Hand Throttle Control Cable Assembly	
Replacement	0219 00-1
Handle and Arms	
Ramp Lock	
All Except M577A3 and M1068A3	
Replacement	0524 00-1
Harness	
Cascade Remote	
M1068A3	
Replacement	0847 00-1
Glow plug	
Replacement	0209 00-1
Trailer	
Replacement	0375 00-1
Harness W32	
M1068A3	
Replacement	0848 00-1
Headlight	
Blackout	
Repair	0306 00-1
Replacement	0305 00-1
Headlight guard	
Replacement	0446 00-1

INDEX, cont'd

<u>Subject</u>	<u>WP Sequence No.-Page No.</u>
Headlight high beam selector switch	
Replacement	0333 00-1
Headlights	
Service and infrared	
Repair	0304 00-1
Replacement	0303 00-1
Heat Exchanger	
Battery Box	
Replacement	0718 00-1
Battery Drawer	
M1064A3	
Replacement	0719 00-1
Heat shield	
Turbo exhaust pipe	
Left/right, replace	0226 00-1
Water/Ration	
Mount Bracket (M113A3 Only)	
Replace	0811 00-1
Power Cable (M113A3 Only)	
Replace	0810 00-1
Heater Control Box	
M3 NBC	
M577A3	
Replacement	0792 00-1
Heater control box	
M3 NBC	
M1068A3	
Replacement	0793 00-1
Heater Fuel Supply Hoses	
M113A3 and M58	
Replacement	0685 00-1
Heater Hoses and Fittings	
M3 NBC	
Replace	0784 00-1
Heaters and Controllers	
M3 NBC	
M113A3 Ambulances	
Replacement	0795 00-1
High beam indicator light doesn't work	0050 00-1
High beam selector switch	
Headlight	
Replacement	0333 00-1

INDEX, cont'd

<u>Subject</u>	<u>WP Sequence No.-Page No.</u>
Hinges	
Turbine access door	
M58	
Replacement.....	0487 00-1
Hold-open Hook	
Driver's Hatch	
M113A3, M1059A3, M1064A3, and M58	
Replacement.....	0532 00-1
Hold-Open Hook and Bumper	
Driver's Hatch	
M577A3 and M1068A3	
Replacement.....	0533 00-1
Hold-open hook and bumper	
Commander's cupola	
M113A3, M1059A3, M58, and M1064A3	
Replacement.....	0494 00-1
Hook and bumper	
Commander's cupola hold-open	
M113A3 and M1059A3	
Replacement.....	0494 00-1
Commander's hatch	
M577A3 and M1068A3	
Replacement.....	0501 00-1
Hook and bumpers	
Cargo hatch hold-open	
M113A3 and M1059A3	
Replacement.....	0474 00-1
Hook and Eye	
Towing	
Replacement.....	0443 00-1
Hopper hatch	
M58	
Replacement.....	0484 00-1
Hopper hatch lock assembly	
M58	
Replacement.....	0483 00-1
Horn and ground lead	
Replacement.....	0336 00-1
Horn does not work	0037 00-1
Horn switch	
All Except M58	
Replacement.....	0293 00-1

INDEX, cont'd

<u>Subject</u>	<u>WP Sequence No.-Page No.</u>
M58	
Replacement.....	0293 01-1
Hose	
Balance	
Replacement.....	0234 00-1
Battery Plate to Battery Plate	
Replacement.....	0722 00-1
Bulkhead to Ramp Cylinder	
Replacement.....	0665 00-1
Coolant Heater to Surge Tank	
Replacement.....	0725 00-1
Engine to battery box	
Replacement.....	0714 00-1
Fuel Pump Tee To Elbow	
Replacement.....	0721 00-1
Fuel Pump to Bulkhead Connection	
M113A3 , M1059A3, and M58	
Replacement.....	0691 00-1
Fuel return	
Engine	
Replacement.....	0201 00-1
Fuel supply	
Engine	
Replacement.....	0200 00-1
Fuel Tank to Fuel Pump	
M577A3 and M1068A3	
Replacement.....	0690 00-1
Personnel heater	
M577A3 and M1068A3	
Replacement.....	0700 00-1
Quick Disconnect to Adapter Access Plate	
Fog Oil Tank (M1059A3)	
Replace.....	0769 00-1
Hose, restriction indicator	
Air cleaner	
Replace.....	0172 00-1
Hoses	
Auxiliary power unit bulkhead-to-hull fuel supply	
M577A3 and M1068A3	
Replacement.....	0678 00-1
Auxiliary Power Unit Valve-to-bulkhead Fuel Supply	
M577A3 and M1068A3	
Replacement.....	0677 00-1

INDEX, cont'd

<u>Subject</u>	<u>WP Sequence No.-Page No.</u>
■ Filter Fuel Supply	
M113A3, M1059A3, and M58	
Replacement.....	0685 00-1
Fuel Vent	
M577A3 and M1068A3	
Replace.....	0198 00-1
Heater Fuel Supply	
■ M113A3, M1059A3, and M58	
Replacement.....	0685 00-1
M13 NBC heater	
M1068A3 only	
Replace.....	0790 00-1
Thermostat	
Replacement.....	0238 00-1
Transmission oil supply and return	
Replacement.....	0251 00-1
Hoses from thermostat to	
Variable speed drive	
Replacement.....	0250 00-1
Hoses	
■ Thermostat.....	0250 00-1
Hoses from thermostat to variable speed drive	
Replacement.....	0250 00-1
Hoses, Tubes, and Fittings	
Fuel Supply	
M1064A3	
Replacement.....	0194 00-1
■ M113A3, M1059A3, and M58	
Replacement.....	0192 00-1
Hoses, tubes, and fittings	
Fuel supply	
M577A3 and M1068A3	
Replacement.....	0193 00-1
Hose	
Variable Speed Drive	
■ Override Switch.....	0251 00-1
How to Use Troubleshooting	
Introduction.....	0005 00-1
Hub	
Road wheel	
Replacement.....	0416 00-1
Hull	
Repair By Welding.....	0529 00-1

INDEX, cont'd

<u>Subject</u>	<u>WP Sequence No.-Page No.</u>
Hull drain plug	
Replacement	0451 00-1
Hull drain plugs	
Final drive	
Replacement	0452 00-1
Hull front access cover	
Replacement	0449 00-1
Hydraulic Reservoir	
Breather	
Service	0670 00-1
Hydraulic Hoses	
Power Plant	
Replacement	0668 00-1
Hydraulic Pump	
Ramp	
Replacement	0655 00-1
Hydraulic Reservoir	
Repair	0672 00-1
Hydraulic Reservoir	
Replacement	0671 00-1
Service	0669 00-1
I	
Idler Arm	
Replacement	0246 00-1
Idler wheel	
Replacement	0425 00-1
Idler wheel arm assembly	
Replacement	0417 00-1
Idler wheel arm bearings and seals	
Replacement	0418 00-1
Igniter	
Air Heater	
Replacement	0207 00-1
Replacement	0730 00-1
Ignition Coil	
Air Box	
Replacement	0208 00-1
Impact absorber	
Driver's Seat	
Replacement	0555 00-1
In blackout mode, fluorescent lights operate incorrectly	
M1068A3 only	0101 00-1

INDEX, cont'd

<u>Subject</u>	<u>WP Sequence No.-Page No.</u>
Indicator lights	
Replacement	0286 00-1
Infrared headlight(s) don't work	0032 00-1
Initial Installation of Litter Kit	
M113A3	0741 00-1
Inoperable ramp	
Lower	0513 00-1
Raise	0513 00-1
Instrument panel	
Battery-generator gauge, wiring harness	
Replacement	0289 00-1
Instrument panel and/or trans controller illumination lights malfunction	0038 00-1
Instrument Panel Assembly	
All Except M58	
Replacement	0279 00-1
Instrument panel Assembly	
M58	
Replacement	0279 01-1
Instrument panel gauges	
Replacement	0285 00-1
Instrument Panel Mounts and Ground Lead	
All Except M58	
Replacement	0295 00-1
M58	
Replacement	0295 01-1
Instrument panel on-off switches	
Replacement	0282 00-1
Instrument panel special purpose cable	
Replacement	0290 00-1
Instrument Warning Light Panel	
Replacement	0288 00-1
Insulation	
Battery Box	
Replacement	0718 00-1
Battery Drawer	
M1064A3	
Replacement	0719 00-1
Intercom Amplifier	
M58	
Replace	0888 00-1
Intercommunications Set Control	
M58	
Replacement	0885 00-1

INDEX, cont'd

<u>Subject</u>	<u>WP Sequence No.-Page No.</u>
Interior Latch	
Driver's Hatch	
Replacement.....	0534 00-1
Interior latch	
Cargo hatch	
M113A3 and M1059A3	
Replacement.....	0475 00-1
Commander's cupola	
M113A3, M1059A3, M58, and M1064A3	
Replacement.....	0496 00-1
Commander's hatch	
M577A3 and M1068A3	
Replacement.....	0502 00-1
Interior Lock	
Driver's Hatch	
Replacement.....	0534 00-1
Interior release mechanisms	
Mortar hatch	
M1064A3	
Replacement.....	0481 00-1
Intervehicle power cable	
M577A3 and M1068A3	
Replacement.....	0381 00-1
Inverter	
Housing A2 Terminal Blocks TB1 and TB2	
M1068A3	
Replacement.....	0830 00-1
Inverter AC Cable (W5)	
Replacement/Repair	0839 00-1
Inverter DC Cable (W6)	
M1068A3	
Replacement.....	0840 00-1
J	
Jump Seat	
Commander's	
M113A3	
Replacement.....	0563 00-1
Junction Box	
Chemical Alarm	
M113A3	
Repair	0920 00-1

INDEX, cont'd

<u>Subject</u>	<u>WP Sequence No.-Page No.</u>
Power Cable/Alarm Cable, Chemical Alarm	
M113A3	
Replacement.....	0919 00-1
K	
Kit	
Initial Installation of Litter	
M113A3	0741 00-1
Kits	
Armor	
M113A3	
Installation	0748 00-1
Mine Armor	
M113A3	
Installation/Removal	0752 00-1
L	
Lamp	
Transmission range controller	
Replacement.....	0388 00-1
LAN (M1068A3)	
Ground Box Assembly A15	
Repair	0821 00-1
Replace.....	0820 00-1
LAN A or B Cable	
(W103/W104)	
M1068A3	
Replacement.....	0854 00-1
LAN Cable (W40) Single Point	
M1068A3	
Replacement.....	0851 00-1
Latch	
Interior	
Driver's Hatch	
Replacement.....	0338 00-1
Lead	
Battery ground	
M577A3 and M1068A3	
Connect	0338 00-1
Disconnect	0338 00-1
Horn and ground	
Replacement.....	0336 00-1
Power Control Enclosure Circuit 44A	
M1068A3	
Replacement.....	0829 00-1

INDEX, cont'd

<u>Subject</u>	<u>WP Sequence No.-Page No.</u>
Lead (circuit 49)	
Master switch to distribution box	
M113A3 , M1059A3, M1064A3, and M58 only	
Replacement.....	0266 00-1
M577A3 and M1068A3 only	
Replacement.....	0267 00-1
Lead (circuit 50)	
Master switch to auxiliary power receptacle	
M113A3 , M1059A3, M1064A3, and M58	
Replacement.....	0268 00-1
Lead assembly	
Master switch panel dome lights	
M577A3 and M1068A3	
Replacement.....	0380 00-1
Utility outlet	
M577A3 and M1068A3	
Replacement.....	0377 00-1
Leads and terminals	
Battery	
M113A3 and M1059A3	
Replacement.....	0340 00-1
M577A3 and M1068A3	
Replacement.....	0341 00-1
M58	
Replacement.....	0345 00-1
Leads and terminals (left side)	
Battery	
M1064A3	
Replacement.....	0343 00-1
Leads and terminals (right side)	
Battery	
M1064A3	
Replacement.....	0344 00-1
Left Air Box	
Drain Check Valve and tubes	
Replace.....	0159 00-1
Left Bulkhead Radio Stowage Racks	
M577A3 and M1068A3	
Replacement.....	0577 00-1
Left front armor plate	
Replacement.....	0447 00-1
Left rear utility outlet/blower does not work	
M577A3 and M1068A3 only	0043 00-1

INDEX, cont'd

<u>Subject</u>	<u>WP Sequence No.-Page No.</u>
Left Side Rack Base	
M1068A3	
Replacement.....	0616 00-1
Left side spall liners	
M113A3	
Replacement.....	0505 00-1
Left stop light - tail light	
M577A3 and M1068A3	
Replacement.....	0299 00-1
Repair 0300 00-1	
Left Table	
M577A3	
Replacement.....	0578 00-1
Lens	
Dome light	
All Except M577A3 and M1068A3	
Replacement.....	0313 00-1
Lever	
Throttle valve (TV)	
Replacement.....	0218 00-1
Lever and Cable	
Ramp Lock	
M577A3 and M1068A3	
Replacement.....	0525 00-1
Lid and Latches	
External Communication Box A11	
Replace (M1068A3)	0818 00-1
Lifting Eye	
Replacement.....	0444 00-1
Light	
Blackout marker	
Repair.....	0308 00-1
Replacement.....	0307 00-1
Dome	
All Except M577A3 and M1068A3	
Repair.....	0310 00-1
Replacement.....	0309 00-1
M577A3 and M1068A3	
Repair.....	0312 00-1
Replacement.....	0311 00-1

INDEX, cont'd

<u>Subject</u>	<u>WP Sequence No.-Page No.</u>
Light Assemblies	
Fluorescent	
M1068A3	
Replacement.....	0825 00-1
Light Assembly	
Tent	
M577A3 and M1068A3	
Replacement.....	0318 00-1
Light Indicators	
Power Control Enclosure AC and DC	
M1068A3	
Replacement.....	0827 00-1
Light panel	
Instrument warning	
Replacement.....	0288 00-1
Light switch	
Main	
Replacement.....	0283 00-1
Lights	
Indicator	
Replacement.....	0286 00-1
Instrument Panel Warning	
Replacement.....	0287 00-1
Panel	
Replacement.....	0286 00-1
Warning Panel	
M58	
Replacement.....	0294 01-1
Warning panel	
All Except M58	
Replacement.....	0294 00-1
Linkage	
Accelerator	
Adjust	0214 00-1
Fuel Control	
Replacement.....	0217 00-1
Ramp	
M1064A3	
Replacement.....	0528 00-1
M113A3 and M1059A3	
Replacement.....	0526 00-1
M577A3 and M1068A3	
Replacement.....	0527 00-1

INDEX, cont'd

<u>Subject</u>	<u>WP Sequence No.-Page No.</u>
Steering wheel	
Adjustment	0427 00-1
Replacement	0430 00-1
Litter Kit	
Initial Installation of	
M113A3	0741 00-1
Lock	
Interior	
Driver's Hatch	
Replacement	0534 00-1
Ramp	
M1064A3	
Adjustment	0523 00-1
M113A3 and M1059A3	
Adjustment	0521 00-1
M577A3 and M1068A3	
Adjustment	0522 00-1
Lock assembly	
Hopper hatch	
M58	
Replacement	0483 00-1
Locks and Seals	
Vision Block	
Driver's Hatch	
Replacement	0535 00-1
Loop and strap	
Water barrier	
M113A3, M577A3, and M1068A3 only	
Replacement	0457 00-1
Loops	
Tool Box	
Replacement	0571 00-1
Lower Fuel Line	
Air Box Heater	
Replacement	0206 00-1
M	
M114 NBC Hoses and Brackets	
Replace	0783 00-1
M13 Air purifier and frame	
M1068A3 only	
Replace	0779 00-1
M13 NBC Filter	
Mount Bracket	

INDEX, cont'd

<u>Subject</u>	<u>WP Sequence No.-Page No.</u>
M577A3	
Replacement.....	0803 00-1
Switch	
M577A3	
Replacement.....	0803 00-1
M13 NBC Filter switch	
M1068A3 only	
Replace.....	0805 00-1
M13 NBC Filters and Hoses	
Replace	0786 00-1
M13 NBC Filters and hoses	
M1068A3 only	
Replace.....	0789 00-1
M13 NBC Heater	
Wiring Harness	
M577A3	
Replacement.....	0808 00-1
M13 NBC heater hoses	
M1068A3 only	
Replace.....	0790 00-1
M13 NBC Heater wiring harness	
M1068A3 only	
Replace.....	0809 00-1
M13 NBC Heaters	
M1068A3	
Replacement.....	0798 00-1
M13 Orifice connector assembly, bracket, and quick coupling half	
M1068A3 only	
Replace	0781 00-1
M14 NBC Cables and switch assembly	
M1059A3	
Replacement.....	0799 00-1
M14 NBC Heater	
Wiring Harness	
(M113A3 Ambulance)	
Replace.....	0807 00-1
M3 NBC Heater	
Bracket	
M113A3	
Replacement.....	0791 00-1
Control box	
M113A3	
Replace.....	0791 00-1

INDEX, cont'd

<u>Subject</u>	<u>WP Sequence No.-Page No.</u>
Regulator	
M113A3	
Replacement.....	0791 00-1
Wiring Harness (M1059A3)	
Replace.....	0806 00-1
M3 NBC Heater Control Box	
M577A3	
Replacement.....	0792 00-1
M3 NBC Heater control box	
M1068A3	
Replacement.....	0793 00-1
M3 NBC Heater Hoses and Fittings (M113A3 Ambulance)	
Replace	0784 00-1
M3 NBC Heaters and Controllers	
M113A3 Ambulances	
Replacement.....	0795 00-1
M3 NBC Hoses and Fittings	
Replace	0788 00-1
M43 Unit Interface Wiring Harnesses	
Chemical Alarm	
M113A3	
Replacement.....	0923 00-1
M8A3 NBC Cables, Switch Assembly, and Brackets	
M577A3	
Replacement.....	0801 00-1
M8A3 NBC Hoses and Brackets	
Replace.....	0785 00-1, 0787 00-1
M8A3/M14 Orifice connector assembly, support, and quick coupling half	
M113A3, M1059A3, and M577A3 only	
Replace.....	0780 00-1
M8A3/M3 NBC Filter	
Switch Assembly (M1059A3)	
Replace.....	0804 00-1
Machine gun mount	
Commander's cupola	
M113A3, M1059A3, M58, and M1064A3	
Repair	0498 00-1
Replacement.....	0497 00-1
Machine gun mount stops	
Commander's cupola	
M1059A3	
Replacement.....	0499 00-1
Main light switch	

INDEX, cont'd

<u>Subject</u>	<u>WP Sequence No.-Page No.</u>
Replacement	0283 00-1
Maintenance Allocation Chart (MAC)	0925 00-1
Malfunction/Symptom Index	0006 00-1
Map Board	
M1068A3	
Replacement	0618 00-1
M577A3	
Replacement	0580 00-1
Map Storage Box	
M1068A3	
Repair	0620 00-1
Replacement	0619 00-1
Master switch	
M113A3 , M1059A3, M1064A3, and M58 only	
Replacement	0262 00-1
Master switch on indicator doesn't light	0048 00-1
Master switch panel	
M113A3 , M1059A3, M1064A3, and M58	
Replacement	0260 00-1
M577A3 and M1068A3 only	
Replacement	0261 00-1
Master switch panel dome lights lead assembly	
M577A3 and M1068A3	
Replacement	0380 00-1
Master switch to auxiliary power receptacle lead (circuit 50)	
M113A3 , M1059A3, M1064A3, and M58	
Replacement	0268 00-1
Master switch to distribution box lead (circuit 49)	
M113A3 , M1059A3, M1064A3, and M58 only	
Replacement	0266 00-1
M577A3 and M1068A3 only	
Replacement	0267 00-1
Materials and Expendable Supplies List	0928 00-1
Meters	
Power Control Enclosure AC and DC	
M1068A3	
Replacement	0827 00-1
Modulator	
Throttle valve (TV)	
Replacement	0218 00-1
Mortar hatch covers	
M1064A3	
Replacement	0482 00-1

INDEX, cont'd

<u>Subject</u>	<u>WP Sequence No.-Page No.</u>
Mortar hatch exterior catches and bumpers	
M1064A3	
Replacement.....	0480 00-1
Mortar hatch interior release mechanisms	
M1064A3	
Replacement.....	0481 00-1
Mount	
Dome light	
M577A3 and M1068A3	
Repair.....	0312 00-1
Driver's Hatch Night Vision	
M58	
Replacement.....	0537 01-1
Fire Extinguisher	
M1059A3	
Replacement.....	0896 00-1
Fire Extinguisher, Portable	
All Except M1068A3	
Replacement.....	0895 00-1
M1068A3	
Replacement/Repair	0897 00-1
M1068A3	
Replacement.....	0834 00-1
Shock absorber	
Replacement.....	0436 00-1
Track tension adjuster	
Replacement.....	0419 00-1
Mount and Bracket	
APIU Rack	
M1068A3	
Replacement.....	0813 00-1
Mount Bracket	
M13 NBC Filter	
M577A3	
Replacement.....	0803 00-1
Water/Ration Heater	
(M113A3 Only)	
Replace.....	0811 00-1
Mounting	
Pamphlet bag	
Repair	0442 00-1
Mounting Blocks	

INDEX, cont'd

<u>Subject</u>	<u>WP Sequence No.-Page No.</u>
Fuel Valve	
All Except M577A3 and M1068A3	
Replacement.....	0199 00-1
Mounting Bracket	
Commander's Display (DVE)	
M58	
Replacement.....	0866 06-1
Driver's Display (DVE)	
M58	
Replacement.....	0866 02-1
Glow Plug Controller	
Replacement.....	0212 00-1
Mounting Bracket, and Switch	
NBC Orifice Connector Assembly	
M58	
Replacement.....	0916 00-1
Mounts	
Transmission	
Replacement.....	0385 00-1
Mounts and Ground Lead	
Instrument Panel	
All Except M58	
Replacement.....	0295 00-1
M58	
Replacement.....	0295 01-1
Mounts, Engine	
Replace.....	0158 00-1
Muffler	
Bracket	
Replace.....	0224 00-1
Muffler Extension and Cap	
Replacement.....	0223 00-1
N	
NATO Auxiliary power (slave) receptacle	
M577A3 and M1068A3 only	
Replacement.....	0264 00-1
NBC	
Air Purifier and Frame	
M113A3	
Replace.....	0775 00-1
M58	
Replacement.....	0914 00-1
Cable Assembly	

INDEX, cont'd

<u>Subject</u>	<u>WP Sequence No.-Page No.</u>
M58	
Removal/Installation	0917 00-1
Cable to Heaters, Air Purifier, and Switch	
M113A3	
Replacement.....	0800 00-1
Hose Assemblies	
M58	
Removal/Installation	0915 00-1
NBC Brackets	
M8A3	
M577A3	
Replacement.....	0801 00-1
NBC Cables	
M8A3	
M577A3	
Replacement.....	0801 00-1
NBC Filter	
Mount Bracket	
M577A3	
Replacement.....	0803 00-1
Switch	
Replacement.....	0803 00-1
Switch Assembly	
M113A3 and M113A3 Ambulance	
Replacement.....	0802 00-1
NBC Filter switch	
M13	
M1068A3 only	
Replace.....	0805 00-1
NBC Filters and hoses	
M13	
M1068A3 only	
Replace.....	0789 00-1
NBC Heater	
Hoses and Fittings	
Replace.....	0782 00-1
NBC Heater Control Box	
M3	
M577A3	
Replacement.....	0792 00-1
NBC Heater control box	
M3	
M1068A3	

INDEX, cont'd

<u>Subject</u>	<u>WP Sequence No.-Page No.</u>
Replacement.....	0793 00-1
NBC Heater Hoses and Fittings	
Replace	0782 00-1
NBC Heater wiring harness	
M13	
M1068A3 only	
Replace.....	0809 00-1
NBC Heaters	
M13	
M1068A3	
Replacement.....	0798 00-1
NBC Heaters and Controllers	
M113A3	
Replacement.....	0794 00-1
M3	
M113A3 Ambulances	
Replacement.....	0795 00-1
NBC kit	
M14	
Air purifier and frame (M113A3)	
Replace.....	0774 00-1
M8A3	
Air purifier and frame with M3 heater kit (M1059A3)	
Replace.....	0778 00-1
NBC Air purifier and frame (M1059A3)	
Replace.....	0777 00-1
M8A3/M13	
Air purifier and frame (M577A3)	
Replace.....	0776 00-1
NBC Kits	
NBC Heaters and Mounts	
M1059A3	
Replacement.....	0797 00-1
M577A3	
Replacement.....	0796 00-1
NBC Orifice Connector Assembly	
Mounting Bracket, and Switch	
M58	
Replacement.....	0916 00-1
NBC Orifice Connector Assembly, Mounting Bracket, and Switch	
M58	
Replacement.....	0916 00-1
NBC Switch Assembly	

INDEX, cont'd

<u>Subject</u>	<u>WP Sequence No.-Page No.</u>
M8A3	
M577A3	
Replacement.....	0801 00-1
Night vision guard	
Driver's Hatch	
M58	
Replacement.....	0536 01-1
Night vision mount	
Driver's Hatch	
M58	
Replacement.....	0537 01-1
No AC power from inverters	
M1068A3 only	0109 00-1
No AC power from tent interface panel A5	
M1068A3 only	0091 00-1
No AC/DC input to ATCCS UPS power box	
M1068A3 only	0100 00-1
No data output from data panel A12	
M1068A3 only	0110 00-1
No data output from data panel A13	
M1068A3 only	0112 00-1
No DC output from DC power supply	
M1068A3 only	0108 00-1
No DC power from tent interface panel A5	
M1068A3 only	0092 00-1
No DC power to single point LAN ground box A15	
M1068A3 only	0097 00-1
No exterior lights operate	0029 00-1
No LAN output from data panel A12	
M1068A3 only	0111 00-1
No LAN output from data panel A13	
M1068A3 only	0113 00-1
No power from curbside AC power extension box A7	
M1068A3 only	0094 00-1
No power from curbside UPS power extension box A19	
M1068A3 only	0099 00-1
No power from DC power extension box A9 (all except jack J23)	
M1068A3 only	0095 00-1
No power from DC power extension box A9, jack J23 (JTIDS)	
M1068A3 only	0096 00-1
No power from roadside AC power extension box A6	
M1068A3 only	0093 00-1
No power from UPS power extension box A18	

INDEX, cont'd

<u>Subject</u>	<u>WP Sequence No.-Page No.</u>
M1068A3 only	0098 00-1
No power to AC circuits	
M1068A3 only	0107 00-1
No power to DC circuits	
M1068A3 only	0106 00-1
Nomenclature Cross-Reference List.....	0001 00-10
Non-skid plates	
M1064A3	
Replacement.....	0738 00-1
O	
Oil	
Cooler hoses, fittings, and mounting	
Transmission	
Replacement.....	0399 00-1
Filter element, engine, Replace.....	0165 00-1
Gauge rod/tube, engine, Replace.....	0164 00-1
Oil and Oil Filter Element	
Transmission	
Replacement.....	0398 00-1
Oil can bracket	
Replacement.....	0574 00-1
Oil drain tubes and bracket	
Transmission	
Replacement.....	0384 00-1
Oil high temperature switch	
Transmission	
Replacement.....	0322 00-1
Oil low pressure transmitter and hardware	
Engine	
Replacement.....	0320 00-1
Oil seal	
Differential	
Final drive	
Replacement.....	0404 00-1
Final drive differential	
Replacement.....	0404 00-1
Oil Tank Module	
Fog	
M1059A3	
Replacement.....	0753 00-1
On cargo hatch cover	
Spall liner	
M113A3	

INDEX, cont'd

<u>Subject</u>	<u>WP Sequence No.-Page No.</u>
Replacement.....	0509 00-1
On ramp	
Spall liner	
M113A3	
Replacement.....	0512 00-1
On ramp door	
Spall liner	
M113A3	
Replacement.....	0511 00-1
On-off switches	
Instrument panel	
Replacement.....	0282 00-1
Operator's Intercommunication Set Cable	
M58	
Replacement.....	0894 00-1
Operator's Seat	
M1059A3	
Replacement/Repair.....	0567 00-1
Orifice connector assembly	
M8A3/M14	
M113A3, M1059A3, and M577A3 only	
Replace.....	0780 00-1
Orifice connector assembly, support, and quick coupling half	
M8A3/M14	
M113A3, M1059A3, and M577A3 only	
Replace.....	0780 00-1
Orifice connector support	
M8A3/M14	
M113A3, M1059A3, and M577A3 only	
Replace.....	0780 00-1
Orifice support quick coupling half	
M8A3/M14	
M113A3, M1059A3, and M577A3 only	
Replace.....	0780 00-1
Outlet Tube and Hoses	
Radiator	
Replacement.....	0233 00-1
P	
Pad	
Cushioning	
Replacement.....	0570 00-1
Track shoe	
Replacement.....	0424 00-1

INDEX, cont'd

<u>Subject</u>	<u>WP Sequence No.-Page No.</u>
Pamphlet bag mounting	
Repair	0442 00-1
Panel	
A13, Roadside Data	
M1068A3	
Replacement.....	0835 00-1
Master switch	
M113A3, M1059A3, M1064A3, and M58	
Replacement.....	0260 00-1
M577A3 and M1068A3 only	
Replacement.....	0261 00-1
Warning Light	
All Except M58	
Replacement.....	0292 00-1
Warning light assembly	
All Except M58	
Replacement.....	0291 00-1
Panel Assembly	
Instrument	
All Except M58	
Replacement.....	0279 00-1
M58	
Replacement.....	0279 01-1
Panel lights	
Replacement	0286 00-1
Parking brake	
Adjustment	0408 00-1
Parking brake bracket	
Replacement	0331 00-1
Parking brake control cable assembly	
Replacement	0411 00-1
Parking brake control lever assembly	
Replacement	0412 00-1
Parking brake indicator malfunctions.....	0052 00-1
Parking brake switch	
Replacement	0331 00-1
Pedal	
Accelerator, Lower	
Replacement.....	0215 00-1
Service brake	
Upper and lower	
Replacement.....	0409 00-1
Pedal Assembly	

INDEX, cont'd

<u>Subject</u>	<u>WP Sequence No.-Page No.</u>
Accelerator, Upper	
Replacement.....	0216 00-1
Personnel Heater	
Control Box Bracket	
M1068A3	
Replacement.....	0617 00-1
Duct	
Repair.....	0707 00-1
Duct and Hoses	
Replacement.....	0706 00-1
Intercom Box Bracket	
M1068A3	
Replacement.....	0617 00-1
Personnel heater	
Fuel filter	
Bracket M113A3, M1059A3, and M58	
Replacement.....	0698 00-1
M113A3, M1059A3, and M58	
Replacement.....	0698 00-1
Fuel pump	
M1064A3	
Replacement.....	0697 00-1
M577A3 and M1068A3	
Replacement.....	0696 00-1
Fuel pump hose	
M113A3, M1059A3, and M58	
Replacement.....	0689 00-1
Fuel pump to bulkhead connection hose	
M577A3 AND M1068A3	
Replacement.....	0692 00-1
Fuel pump to fuel shutoff valve hose	
M1064A3	
Replacement.....	0694 00-1
Personnel Heater Assembly	
All Except M1064A3	
Replacement.....	0703 00-1
M1064A3	
Replacement.....	0704 00-1
Repair	0705 00-1
Personnel Heater Fuel Filter	
Service	0680 00-1
Personnel Heater Fuel Pump	
M113A3, M1059A3, and M58	

INDEX, cont'd

<u>Subject</u>	<u>WP Sequence No.-Page No.</u>
Replacement.....	0695 00-1
Service	0681 00-1
Personnel Heater Fuel Tube	
All Except M1064A3	
Replacement.....	0686 00-1
Personnel heater malfunctions	0086 00-1
Personnel Seats, backrests, cushions and belts	
M1059A3	
Replacement.....	0549 00-1
M1064A3	
Replacement.....	0550 00-1
Personnel seats, cushions, and belts	
M113A3	
Replacement.....	0546 00-1
M577A3	
Replacement.....	0547 00-1
Phone extension box A14 post(s) inoperative	
M1068A3 only	0114 00-1
Pin	
Shock absorber	
Replacement.....	0437 00-1
Pintle	
Towing	
Repair	0434 00-1
Replacement.....	0433 00-1
Pipes	
Coolant Heater Exhaust	
Replacement.....	0724 00-1
Front Bilge Pump	
Replace.....	0631 00-1
Rear Bilge Pump	
Replacement.....	0634 00-1
Plate	
Smoke grenade launcher	
M113A3 and M1059A3 only	
Replacement.....	0455 00-1
Plates	
Non-skid	
M1064A3	
Replacement.....	0738 00-1
Platform	
Commander's	
M113A3, M1059A3, M1064A3, and M58	

INDEX, cont'd

<u>Subject</u>	<u>WP Sequence No.-Page No.</u>
Replacement/repair	0559 00-1
M577A3 and M1068A3	
Replacement/Repair	0564 00-1
Plug	
Hull drain	
Replacement	0451 00-1
Portable Fire Extinguisher Mount	
All Except M1068A3	
Replacement	0895 00-1
M1068A3	
Replacement/Repair	0897 00-1
Post	
Commander's	
M113A3, M1059A3, and M58	
Replacement	0560 00-1
M577A3 and M1068A3	
Replacement/Repair	0564 00-1
Commander's seat	
M1064A3	
Replacement	0561 00-1
Post Assembly	
Driver's Seat	
Replacement	0556 00-1
M113A3	
Replacement	0742 00-1, 0743 00-1
Power Cable	
Chemical Alarm	
M113A3	
Replacement	0919 00-1
DVE Sensor Set Assembly	
M58	
Replacement	0866 01-1
Water/Ration Heater	
(M113A3 Only)	
Replace	0810 00-1
Power cable	
Intervehicle	
M577A3 and M1068A3	
Replacement	0381 00-1
Power Control Enclosure	
AC and DC Light Indicators	
M1068A3	
Replacement	0827 00-1

INDEX, cont'd

<u>Subject</u>	<u>WP Sequence No.-Page No.</u>
AC and DC Meters	
M1068A3	
Replacement.....	0827 00-1
Bracket	
M1068A3	
Repair.....	0828 00-1
Circuit 44A Lead	
M1068A3	
Replacement.....	0829 00-1
Faceplate	
M1068A3	
Repair.....	0828 00-1
Power control enclosure A1 DC input/output inoperative	
M1068A3 only	0090 00-1
Power Control Enclosure Assembly	
A1	
M1068A3	
Replacement.....	0826 00-1
Power Distribution Box A3	
M1068A3	
Replacement/Repair	0831 00-1
Power Distribution Cable (W3)	
M1068A3	
Replacement.....	0837 00-1
Power Entry Box Assembly A4	
M1068A3	
Replacement.....	0832 00-1
Power Extension	
Box A18, AC	
M1068A3	
Replacement.....	0836 00-1
Power Extension Box A18 and Bracket	
M1068A3	
Replacement.....	0836 00-1
Power Harness	
Glow Plug	
Replacement.....	0211 00-1
Power Plant	
Block	0157 00-1
Hydraulic Hoses	
Replacement.....	0668 00-1

INDEX, cont'd

<u>Subject</u>	<u>WP Sequence No.-Page No.</u>
Power plant access panel	
Driver's	
Replacement.....	0441 00-1
Power plant assembly	
Removal/Installation	0156 00-1
Power plant bottom access cover	
Replacement.....	0450 00-1
Power plant door	
All except M113A3	
Replacement.....	0471 00-1
M113A3	
Replacement.....	0470 00-1
Repair.....	0472 00-1
Power plant door combat lock	
Replacement.....	0473 00-1
Power plant grill screen	
Replacement.....	0468 00-1
Power plant grill support arm	
Replacement.....	0467 00-1
Power plant grille	
Raise and lower.....	0464 00-1
Removal/installation.....	0465 00-1
Power plant rear access panels	
Repair/Replacement	0439 00-1
Power Plant Sling	
Inspect	0673 00-1
Power Supply	
Storage Box Assembly	
M1068A3	
Replacement/Repair	0824 00-1
Power supply	
Solid state infrared	
Replacement.....	0297 00-1
Power Supply Cable	
Driver's Vision Enhancer (DVE) AN/VAS-5	
M58	
Replacement.....	0866 04-1
Power supply cable assembly	
Driver's night vision (DNV) (AN/VVS-2)	
All Except M58	
Replacement.....	0368 00-1
Pressure switch	
Differential	

INDEX, cont'd

<u>Subject</u>	<u>WP Sequence No.-Page No.</u>
Bypass plug	
Replacement.....	0401 00-1
Transmission oil	
Replacement.....	0400 00-1
Preventive Maintenance Checks and Services (PMCS), Including Lubrication Instructions	
Annual	0155 00-1
Semi-Annual.....	0155 00-1
Principles of Operation	
Auxiliary Automotive System.....	0003 00-2
Special Equipment.....	0003 00-3
Winterization Equipment	0003 00-3
Printer Mount	
Replace/Repair	0823 00-1
Propeller shaft and universal joints	
Replacement.....	0405 00-1
Pulley	
Coolant Pump Idler	
Replacement.....	0240 00-1
Ventilating Fan Drive	
Replacement.....	0244 00-1
Pulse Tachometer	
STE/ICE	
Replacement.....	0867 00-1
Pump	
Coolant Heater	
Replacement.....	0731 00-1
Engine Coolant	
Replacement.....	0241 00-1
Hydraulic	
Ramp	
Replacement.....	0655 00-1
Pump Assembly	
Fog Oil	
(M1059A3 Only)	
Replace.....	0763 00-1
Pump Unit	
Coolant Heater	
Replace.....	0728 00-1
Push-pull control assembly, bracket, links, and pins (cable-activated lock)	
Replacement.....	0429 00-1

INDEX, cont'd

<u>Subject</u>	<u>WP Sequence No.-Page No.</u>
Q	
Quick coupling half	
M13 Orifice	
M1068A3 only	
Replace.....	0781 00-1
M8A3/M14 Orifice support	
M113A3, M1059A3, and M577A3 only	
Replace.....	0780 00-1
Quick release pin and lanyard	
Replacement.....	0431 00-1
Quick release pins and plates	
Spall liner	
M113A3	
Repair.....	0506 00-1
R	
Rack	
Radio	
M58	
Replace.....	0891 00-1
Radio stowage	
M1064A3	
Replacement.....	0609 00-1
Rifle	
M1064A3	
Replacement.....	0612 00-1
Rack Assembly	
Rack Base	
Right Side	
M1068A3	
Replacement.....	0622 00-1
Racks	
Left Bulkhead Radio Stowage	
M577A3 and M1068A3	
Replacement.....	0577 00-1
Radiac wire harness	
M113A3, M577A3, and M1068A3	
Replacement.....	0376 00-1
Radiator	
Clean	0228 00-1
Radiator access door	
Replacement.....	0469 00-1
Radiator and Parts	
Replacement.....	0229 00-1

INDEX, cont'd

<u>Subject</u>	<u>WP Sequence No.-Page No.</u>
Radiator Outlet Tube and Hoses	
Replacement	0233 00-1
Radio Operator's Seat	
M1068A3 and M58	
Replacement/Repair	0568 00-1
Radio Rack	
M58	
Replace	0891 00-1
Radio Stowage Rack	
Right Front	
M577A3	
Replacement	0579 00-1
Radio Stowage Racks	
Left Bulkhead	
M577A3 and M1068A3	
Replacement	0577 00-1
Radio(s) don't work	0044 00-1
Ramp	
Bracket	
M113A3, M577A3, and M1068A3	
Replacement	0516 00-1
Control Valve	
Elbow	
Replacement	0663 00-1
Hose	
Replacement	0663 00-1
Replacement	0660 00-1
Control Valve (with Internal Relief Valve) and Fittings	
Replacement	0661 00-1
Control Valve and Fittings (with External Relief Valve)	
Replacement	0659 00-1
Cylinder	
Replacement	0656 00-1
Cylinder Breather Hose	
All Except M1064A3	
Replacement	0666 00-1
M1064A3	
Replacement	0667 00-1
Door	
Stop Bracket	
Replacement	0517 00-1
External Relief Valve	
Replacement	0660 00-1

INDEX, cont'd

<u>Subject</u>	<u>WP Sequence No.-Page No.</u>
Fittings with Ramp Control Valve (Internal Relief Valve)	
Replacement.....	0660 00-1
Hose	
Bulkhead to Cylinder	
Replacement.....	0665 00-1
Hydraulic Pump	
Replacement.....	0655 00-1
Linkage	
M1064A3	
Replacement.....	0528 00-1
M113A3 and M1059A3	
Replacement.....	0526 00-1
M577A3 and M1068A3	
Replacement.....	0527 00-1
Lock	
M1064A3	
Adjustment.....	0523 00-1
M113A3 and M1059A3	
Adjustment.....	0521 00-1
M577A3 and M1068A3	
Adjustment.....	0522 00-1
Vision Port and Shield	
M58	
Replacement/Repair.....	0586 00-1
Ramp Door	
Handles	
Replacement.....	0519 00-1
Hook	
Replacement.....	0518 00-1
Seal	
Replacement.....	0520 00-1
Shaft	
Replacement.....	0519 00-1
Spring	
Replacement.....	0518 00-1
Ramp door switch and mount	
M577A3 and M1068A3	
Replacement.....	0335 00-1
Ramp drain plugs	
Replacement.....	0515 00-1

INDEX, cont'd

<u>Subject</u>	<u>WP Sequence No.-Page No.</u>
Ramp Lock	
Handle and Arms	
All Except M577A3 and M1068A3	
Replacement.....	0524 00-1
Lever and Cable	
M577A3 and M1068A3	
Replacement.....	0525 00-1
Ramp operation is slow or sluggish.....	0083 00-1
Ramp seal	
Replacement.....	0514 00-1
Ramp will not lower	0082 00-1
Ramp will not raise or free falls	0084 00-1
Range controller	
Bracket	
Used with solenoid-activated steering lock	
Replacement.....	0386 00-1
Transmission	
Used with cable-activated steering lock	
Replacement.....	0387 00-1
Used with solenoid-activated steering lock	
Replacement.....	0386 00-1
Range controller lamp	
Transmission	
Replacement.....	0388 00-1
Range controller switch	
Transmission	
Replacement.....	0389 00-1
Rear access panels	
Power plant	
Repair/Replacement.....	0439 00-1
Rear Armor	
M113A3	
Replacement.....	0751 00-1
Rear Bilge Pump	
Replacement.....	0635 00-1
Strainer	
Replacement.....	0635 00-1
Rear Bilge Pump Pipes	
Replacement.....	0634 00-1
Rear compartment air ventilator	
Replacement.....	0454 00-1

INDEX, cont'd

<u>Subject</u>	<u>WP Sequence No.-Page No.</u>
Rear dome light switch	
M577A3 and M1068A3	
Replacement.....	0315 00-1
Rear external stowage frame	
M1068A3	
Replacement.....	0626 00-1
Rear main wiring harness	
M1064A3	
Replacement.....	0364 00-1
M1068A3	
Replacement.....	0365 00-1
M113A3, M1059A3, and M58	
Replacement.....	0362 00-1
M577A3	
Replacement.....	0363 00-1
Rear tiedown plates	
Replacement.....	0445 00-1
Rear upper hull spall liner	
M113A3	
Replacement.....	0510 00-1
Rear utility outlet receptacles	
M577A3 and M1068A3	
Replacement.....	0378 00-1
Rear utility receptacle circuit breakers	
M577A3 and M1068A3 only	
Replacement.....	0276 00-1
Receptacle	
Auxiliary power (slave)	
M113A3 , M1059A3, M1064A3, and M58 only	
Replacement.....	0263 00-1
NATO Auxiliary power (slave)	
M577A3 and M1068A3 only	
Replacement.....	0264 00-1
Receptacles	
Rear utility outlet	
M577A3 and M1068A3	
Replacement.....	0378 00-1
Reel holder assembly	
Cable	
M1064A3	
Repair.....	0604 00-1

INDEX, cont'd

<u>Subject</u>	<u>WP Sequence No.-Page No.</u>
Reel holder assembly, cable	
M1064A3	
Replacement.....	0603 00-1
References	0924 00-1
Refill Tray Bracket	
Chemical Alarm	
M113A3	
Replacement.....	0922 00-1
Regulator	
Voltage	
Adjustment.....	0256 00-1
Regulator assembly	
Replacement.....	0257 00-1
Release	
Trim vane	
Repair	0463 00-1
Replacement.....	0462 00-1
Release mechanisms	
Mortar hatch interior	
M1064A3	
Replacement.....	0481 00-1
Restriction indicator	
Air cleaner	
Replace.....	0171 00-1
Retainer	
Batteries	
M1064A3	
Replacement.....	0349 00-1
Repair Parts, Special Tools, TMDE, and Support Equipment.....	0004 00-1
Rifle Brackets	
Replacement.....	0573 00-1
Rifle Rack	
M1064A3	
Replacement.....	0612 00-1
Right Equipment Rack	
Brackets and Mounts	
M1068A3	
Replacement.....	0814 00-1
Right Forward Table	
M577A3	
Replacement.....	0581 00-1
Right front armor plate	
Replacement.....	0448 00-1

INDEX, cont'd

<u>Subject</u>	<u>WP Sequence No.-Page No.</u>
Right Front Radio Stowage Rack	
M577A3	
Replacement.....	0579 00-1
Right headlight wiring harness	
Replace	0373 00-1
Right rear utility outlet/admittance buzzer works improperly	
M577A3 and M1068A3 only	0042 00-1
Right Rearward Table	
M577A3	
Replacement.....	0582 00-1
Right Side Base Extension	
M1068A3	
Replacement.....	0623 00-1
Right side spall liners	
M113A3	
Replacement.....	0504 00-1
Right stop light - tail light	
M577A3	
Replacement.....	0301 00-1
Repair.....	0302 00-1
Road wheel	
T130	
Replacement.....	0426 00-1
T150	
Replacement.....	0426 01-1
Road wheel hub	
Replacement.....	0416 00-1
Road wheel support arm, bearings, and seals	
Replacement.....	0415 00-1
Roadside Data Panel A13	
M1068A3	
Replacement.....	0835 00-1
S	
Safety pin stowage block	
Commander's cupola	
M113A3, M1059A3, M58, and M1064A3	
Replacement.....	0495 00-1
Safety Relief Valve	
Fittings	
Replacement.....	0662 00-1
Hose	
Replacement.....	0662 00-1

INDEX, cont'd

<u>Subject</u>	<u>WP Sequence No.-Page No.</u>
Tube	
Replacement.....	0662 00-1
Sampling valve	
Transmission oil	
Replacement.....	0400 00-1
Schematic	
All except M577A3 and M1068A3	
Engine fuel system.....	0009 00-1
Bilge pump.....	0078 00-1
Coolant heater.....	0087 00-1
Engine charging system.....	0007 00-1
Engine starter circuit.....	0011 00-1
Indicators.....	0046 00-1
STE/ICE.....	0136 00-1
Electrical.....	0027 00-1
(cable-activated lock)	
Steering lock.....	0075 00-1
Engine air box heater.....	0013 00-1
M577A3 and M1068A3	
Engine fuel system.....	0010 00-1
Personnel heater.....	0085 00-1
Ramp.....	0081 00-1
(solenoid-activated lock)	
Steering lock.....	0074 00-1
Transmission.....	0060 00-1
Seal	
Ramp	
Replacement.....	0514 00-1
Ramp Door	
Replacement.....	0520 00-1
Seals	
Cargo hatch	
M113A3 and M1059A3	
Replacement.....	0478 00-1
Idler wheel arm	
Replacement.....	0418 00-1
Road wheel support	
Replacement.....	0415 00-1
Seat	
Commander's	
M1064A3	
Replacement.....	0561 00-1

INDEX, cont'd

<u>Subject</u>	<u>WP Sequence No.-Page No.</u>
M1068A3	
Replacement/repair	0566 00-1
M113A3, M1059A3, and M58	
Replacement.....	0560 00-1
M113A3, M1059A3, M1064A3, and M58	
Repair	0562 00-1
Commander's Jump	
M113A3	
Replacement.....	0563 00-1
Driver's	
Post assembly	
Repair	0557 00-1
Repair	0552 00-1
Replacement.....	0551 00-1
Operator's	
M1059A3	
Replacement/Repair	0567 00-1
Personnel	
M1059A3	
Replacement.....	0549 00-1
M1064A3	
Replacement.....	0550 00-1
Radio Operator's	
M58	
Replacement/Repair	0568 00-1
Seats	
Personnel	
M113A3	
Replacement.....	0546 00-1
M577A3	
Replacement.....	0547 00-1
Sensors	
Switches	
Replace.....	0321 01-1
Sensor Set Assembly Adapter	
AN/VAS-5 Driver's Night Vision Enhancer (DVE)	
M58	
Replacement.....	0866 05-1
Service and infrared headlights	
Repair	0304 00-1
Replacement	0303 00-1
Service and/or black out stop lights malfunction	0033 00-1
Service and/or parking brake won't hold carrier.....	0064 00-1

INDEX, cont'd

<u>Subject</u>	<u>WP Sequence No.-Page No.</u>
Service brake control linkage	
Adjustment	0407 00-1
Replacement	0410 00-1
Service brake pedal	
Upper and lower	
Replacement	0409 00-1
Service headlights don't work	0031 00-1
Service tallight doesn't work	0035 00-1
Service Upon Receipt	0154 00-1
Shaft	
Fuel Control	
Replacement	0217 00-1
Shelf Assembly	
Right Side	
M1068A3	
Replacement	0621 00-1
Shield	
External Handle	
M1064A3	
Replacement	0903 00-1
M113A3 and M1059A3	
Replacement	0901 00-1
M577A3 and M1068A3	
Replacement	0902 00-1
Ramp Vision Port	
M58	
Replacement/Repair	0586 00-1
Shields, Armor, Commander's Cupola	
M113A3 and M1064A3	
Replacement	0747 00-1
Shock absorber	
Replacement	0435 00-1
Shock absorber mount	
Replacement	0436 00-1
Shock absorber pin	
Replacement	0437 00-1
Shunt	
STE/ICE	
M1064A3	
Replacement	0873 00-1
M113A3 and M1059A3	
Replacement	0870 00-1

INDEX, cont'd

<u>Subject</u>	<u>WP Sequence No.-Page No.</u>
M577A3 and M1068A3 Replacement.....	0871 00-1
Shunt Guard	
STE/ICE	
M113A3 and M1059A3 Replacement.....	0868 00-1
Shut-off Valve Assembly	
Fuel	
M113A3, M1059A3, and M58 Replacement.....	0684 00-1
Side Armor	
M113A3 Replacement.....	0750 00-1
Signal Patch Panel Box A10 Replace	0816 00-1
Sling	
Power Plant Inspect	0673 00-1
Smoke Generator	
Adapter Access Plate to Generator Electrical Cable Assembly M1059A3 Replacement.....	0761 00-1
Breather Hose Assembly M1059A3 Replacement.....	0754 00-1
Control Panel Assembly M1059A3 Replace.....	0756 00-1
Internal Cable Assembly M1059A3 Replacement.....	0760 00-1
M1059A3 Replacement.....	0755 00-1
Power Supply Cable Assembly M1059A3 Replacement.....	0757 00-1
Support Bracket M1059A3 Replacement.....	0755 00-1
Smoke Generator (M1059A3)	
Adapter Access Plate Gasket Replace.....	0766 00-1

INDEX, cont'd

<u>Subject</u>	<u>WP Sequence No.-Page No.</u>
Adapter Access Plate to Cover Assembly Air Hose	
Replace.....	0768 00-1
Air Hose	
Compressor Reservoir to Access Plate	
Replace.....	0767 00-1
Armor	
Replace.....	0771 00-1
Fuel Can Lid Assembly	
Replace.....	0764 00-1
Fuel Filter	
Replace.....	0773 00-1
Fuel Lines and Guards	
Replace.....	0765 00-1
Glow Plug Cable Assembly	
Replace.....	0772 00-1
Water Separator	
Replace.....	0773 00-1
Smoke grenade launcher guard, plate, and base	
M113A3 and M1059A3 only	
Replacement.....	0455 00-1
Smoke grenade launcher wiring harness	
M113A3 , M1059A3, and M58	
Replacement.....	0366 00-1
Smoke grenade launcher(s) malfunction	
M113A3 and M1059A3	0045 00-1
Solenoid, bracket, links, and pins (solenoid-activated lock)	
Steering lock	
Replacement.....	0428 00-1
Solenoid-activated steering lock malfunctions	0076 00-1
Solid state infrared power supply	
Replacement.....	0297 00-1
Spall liner	
Rear upper hull	
M113A3	
Replacement.....	0510 00-1
Spall liner and bracket	
Forward	
M113A3	
Replacement.....	0507 00-1
Spall liner on cargo hatch cover	
M113A3	
Replacement.....	0509 00-1

INDEX, cont'd

<u>Subject</u>	<u>WP Sequence No.-Page No.</u>
Spall liner on ramp	
M113A3	
Replacement.....	0512 00-1
Spall liner on ramp door	
M113A3	
Replacement.....	0511 00-1
Spall liner quick release pins and plates	
M113A3	
Repair.....	0506 00-1
Spall liners	
Forward upper right and left side	
M113A3	
Replacement.....	0508 00-1
Left side	
M113A3	
Replacement.....	0505 00-1
Right side	
M113A3	
Replacement.....	0504 00-1
Special purpose cable	
Instrument panel	
Replacement.....	0290 00-1
Speedometer	
Cable	
Adapter	
Replace.....	0860 00-1
Replace.....	0860 00-1
Service.....	0858 00-1
Replace.....	0859 00-1
Speedometer Cable	
Repair.....	0861 00-1
Speedometer malfunctions.....	0115 00-1
Spring Tensioner	
Idler Arm	
Replacement.....	0246 00-1
Start switch	
Engine	
Replacement.....	0284 00-1
Starter	
Replace.....	0259 00-1
Starter relay switch	
Replacement.....	0258 00-1

INDEX, cont'd

<u>Subject</u>	<u>WP Sequence No.-Page No.</u>
STE/ICE	
Pulse Tachometer	
Replacement.....	0867 00-1
Shunt	
M1064A3	
Replacement.....	0873 00-1
M113A3 and M1059A3	
Replacement.....	0870 00-1
M577A3 and M1068A3	
Replacement.....	0871 00-1
Shunt Guard	
M113A3 and M1059A3	
Replacement.....	0868 00-1
STE/ICE Crew Wiring Harness	
M1064A3	
Replacement.....	0881 00-1
M113A3 and M1059A3	
Replacement.....	0878 00-1
M577A3 and M1068A3	
Replacement.....	0879 00-1
STE/ICE Distribution Box	
M1064A3	
Replacement.....	0877 00-1
M113A3 and M1059A3	
Replacement.....	0874 00-1
M577A3 and M1068A3	
Replacement.....	0875 00-1
STE/ICE Engine Wiring Harness	
Replacement.....	0882 00-1
STE/ICE test set to DCA 6	
Hook up.....	0117 00-1
Remove.....	0117 00-1
Steering	
Transmission	
Adjust.....	0393 00-1
Steering lock solenoid, bracket, links, and pins (solenoid-activated lock)	
Replacement.....	0428 00-1
Steering Lock Switch	
Replacement.....	0330 00-1
Steering Lock Switch Wiring Harness	
All Except M58	
Replacement.....	0367 00-1

INDEX, cont'd

<u>Subject</u>	<u>WP Sequence No.-Page No.</u>
M58	
Replacement.....	0367 01-1
Steering locked indicator malfunctions	0054 00-1
Steering support, brackets, and shaft	
Replacement.....	0432 00-1
Steering wheel linkage	
Adjustment.....	0427 00-1
Replacement.....	0430 00-1
Stencils	
M1059A3	0640 00-1
M1064A3	0641 00-1
M1068A3	0642 00-1
M113A3	0636 00-1
M577A3	0637 00-1
M58	0643 00-1
Stop light - tail light	
Left	
M577A3 and M1068A3	
Replacement.....	0299 00-1
Repair.....	0300 00-1
Right	
M577A3	
Replacement.....	0301 00-1
Repair	0302 00-1
Stop light - tail light and guards	
All Except M577A3 and M1068A3	
Replacement.....	0298 00-1
Stop switch	
Replacement.....	0332 00-1
Storage Box Assembly	
Power Supply	
M1068A3	
Replacement/Repair	0824 00-1
Stowage	
Driver's Night Vision (AN/VVS-2)	
All Except M58	
Replacement.....	0572 00-1
Stowage Box	
M113A3	
Replacement.....	0750 00-1

INDEX, cont'd

<u>Subject</u>	<u>WP Sequence No.-Page No.</u>
Stowage box	
Grenade	
M1064A3	
Replacement.....	0610 00-1
Periscope	
M1064A3	
Replacement.....	0611 00-1
Stowage Bracket	
AN/VAS-5 Driver's Vision Enhancer	
M58	
Replacement.....	0866 03-1
Track shoe.....	0575 01-1
Sight Extension Arm	
M1064A3	
Replacement.....	0613 00-1
Stowage Brackets for W1, W2, and NATO Slave Cables	
M1068A3 and M577A3	
Replacement.....	0626 01-1
Stowage frame	
Rear external	
M1068A3	
Replacement.....	0626 00-1
Stowage Rack	
Right Front Radio	
M577A3	
Replacement.....	0579 00-1
Stowage Racks	
Left Bulkhead Radio	
M577A3 and M1068A3	
Replacement.....	0577 00-1
Strainer	
Front Bilge Pump	
Replace.....	0632 00-1
Rear Bilge Pump	
Replacement.....	0635 00-1
Strainer Parts	
Filler Cap	
All Except M577A3 and M1068A3	
Replacement.....	0184 00-1
M577A3 and M1068A3	
Replacement.....	0185 00-1

INDEX, cont'd

<u>Subject</u>	<u>WP Sequence No.-Page No.</u>
Straps	
Webbing	
Replacement.....	0569 00-1
Support	
Antenna	
M58	
Replacement.....	0602 00-1
M8A3/M14 Orifice connector	
M113A3, M1059A3, and M577A3 only	
Replace.....	0780 00-1
Support, brackets, and shaft	
Steering	
Replacement.....	0432 00-1
Switch	
Blower	
M577A3 and M1068A3 only	
Replacement.....	0278 00-1
Differential Pressure	
Replacement.....	0401 00-1
Dome blackout light bypass	
M577A3 and M1068A3	
Replacement.....	0317 00-1
Engine start	
Replacement.....	0284 00-1
Flame Detector	
Adjust.....	0727 00-1
Flame Detetor	
Coolant Heater	
Replacement.....	0734 00-1
Front dome light	
M577A3 and M1068A3	
Replacement.....	0314 00-1
Fuel Filter Differential Pressure	
Replacement.....	0328 00-1
Fuel selector	
M577A3 and M1068A3 only	
Replacement.....	0277 00-1
Generator field pressure	
Replacement.....	0323 00-1
Headlight high beam selector	
Replacement.....	0333 00-1
Horn	
Replacement.....	0293 00-1

INDEX, cont'd

<u>Subject</u>	<u>WP Sequence No.-Page No.</u>
M58	
Replacement.....	0293 01-1
Light	
Main	
Replacement.....	0283 00-1
M13 NBC Filter	
M577A3	
Replacement.....	0803 00-1
Parking brake	
Replacement.....	0331 00-1
Rear dome Light	
M577A3 and M1068A3	
Replacement.....	0315 00-1
Rear dome light	
M577A3 and M1068A3	
Replacement.....	0315 00-1
Starter relay	
Replacement.....	0258 00-1
Steering lock	
Replacement.....	0330 00-1
Stop	
Replacement.....	0332 00-1
Thermostatic Fan Speed	
Replacement.....	0231 00-1
Transmission Oil	
Replacement.....	0400 00-1
Transmission oil high temperature	
Replacement.....	0322 00-1
Transmission range controller	
Replacement.....	0389 00-1
Switch and buzzer	
Admittance	
M577A3 and M1068A3	
Replacement.....	0334 00-1
Switch and mount	
Ramp door	
M577A3 and M1068A3	
Replacement.....	0335 00-1
Switch Assembly	
M8A3/M3 NBC Filter (M1059A3)	
Replace.....	0804 00-1

INDEX, cont'd

<u>Subject</u>	<u>WP Sequence No.-Page No.</u>
NBC Filter	
M113A3 and M113A3 Ambulance	
Replacement.....	0802 00-1
Switch to gauge lead	
Fuel select	
All Except M577A3 and M1068A3	
Replacement.....	0281 00-1
Switches	
On-off	
Instrument panel	
Replacement.....	0282 00-1
T	
Table	
Left	
M577A3	
Replacement.....	0578 00-1
Right forward	
M577A3	
Replacement.....	0581 00-1
Right Rearward	
M577A3	
Replacement.....	0582 00-1
Tachometer	
Cable	
Repair.....	0865 00-1
Replace.....	0864 00-1
Service.....	0858 00-1
Engine adapter	
Replace.....	0863 00-1
Pulse	
STE/ICE	
Replacement.....	0867 00-1
Replace	0862 00-1
Tachometer malfunctions	0116 00-1
Taillight	
Bracket	
M1068A3	
Repair	0625 00-1
Replacement.....	0625 00-1
Wiring Harness	
M1068A3	
Repair	0625 00-1
Replacement.....	0625 00-1

INDEX, cont'd

<u>Subject</u>	<u>WP Sequence No.-Page No.</u>
Tank	
Auxiliary	
Replacement.....	0230 00-1
Tank Module	
Fog Oil	
M1059A3	
Replacement.....	0753 00-1
Teleposts and cover	
Replacement.....	0296 00-1
Tent	
Frame mounts	
M577A3	
Replacement.....	0628 00-1
M577A3	
Replacement.....	0627 00-1
Tent Interface Panel	
Box Assembly A5	
M1068A3	
Replacement.....	0833 00-1
Tent Light Assembly	
M577A3 and M1068A3	
Replacement.....	0318 00-1
Terminal Blocks TB1 and TB2	
Inverter Housing A2	
M1068A3	
Replacement.....	0830 00-1
Terminals and leads	
Battery	
M113A3 and M1059A3	
Replacement.....	0340 00-1
M577A3 and M1068A3	
Replacement.....	0341 00-1
M58	
Replacement.....	0345 00-1
Terminals and leads (left side)	
Battery	
M1064A3	
Replacement.....	0343 00-1
Terminals and leads (right side)	
Battery	
M1064A3	
Replacement.....	0344 00-1

INDEX, cont'd

<u>Subject</u>	<u>WP Sequence No.-Page No.</u>
Test 10 diagnostic troubleshooting	
STE/ICE	0140 00-1
Test 10 engine RPM	
STE/ICE	0118 00-1
Test 11 diagnostic troubleshooting	
STE/ICE	0140 00-1
Test 12 diagnostic troubleshooting	
STE/ICE	0140 00-1
Test 13 diagnostic troubleshooting	
STE/ICE	0140 00-1
Test 24 fuel supply pressure	
STE/ICE	0119 00-1
Test 24 fuel supply pressure diagnostic troubleshooting	
STE/ICE	0143 00-1
Test 25 fuel return pressure	
STE/ICE	0120 00-1
Test 25 fuel return pressure diagnostic troubleshooting	
STE/ICE	0144 00-1
Test 26 fuel filter pressure drop	
STE/ICE	0121 00-1
Test 26 fuel filter pressure drop diagnostic troubleshooting	
STE/ICE	0145 00-1
Test 30 turbocharger outlet pressure	
STE/ICE	0122 00-1
Test 30 turbocharger outlet pressure diagnostic troubleshooting	
STE/ICE	0146 00-1
Test 32 air box pressure	
STE/ICE	0123 00-1
Test 32 air box pressure diagnostic troubleshooting	
STE/ICE	0147 00-1
Test 67 battery voltage	
STE/ICE	0124 00-1
Test 68 starter motor voltage	
STE/ICE	0125 00-1
Test 68 starter motor voltage diagnostic troubleshooting	
STE/ICE	0148 00-1
Test 69 starter negative cable voltage drop	
STE/ICE	0126 00-1
Test 69 starter negative cable voltage drop diagnostic troubleshooting	
STE/ICE	0149 00-1
Test 70 starter solenoid voltage	
STE/ICE	0127 00-1

INDEX, cont'd

<u>Subject</u>	<u>WP Sequence No.-Page No.</u>
Test 70 starter solenoid voltage diagnostic troubleshooting	
STE/ICE	0150 00-1
Test 71 starter current (average)	
STE/ICE	0128 00-1
Test 72 starter current (first peak)	
STE/ICE	0129 00-1
Test 73 battery resistance	
STE/ICE	0130 00-1
Test 74 starter circuit resistance	
STE/ICE	0131 00-1
Test 75 battery resistance change (pack)	
STE/ICE	0130 00-1
Test 80 battery current	
STE/ICE	0132 00-1
Test 82 generator output voltage	
STE/ICE	0133 00-1
Test 82 generator output voltage diagnostic troubleshooting	
STE/ICE	0151 00-1
Test 83 generator field voltage	
STE/ICE	0134 00-1
Test 83 generator field voltage diagnostic troubleshooting	
STE/ICE	0152 00-1
Test 84 generator negative cable voltage drop	
STE/ICE	0135 00-1
Test 84 generator negative cable voltage drop diagnostic troubleshooting	
STE/ICE	0153 00-1
Theory of Operation	0003 00-1
Thermostat	
Replacement	0237 00-1
Thermostatic Fan Speed Switch	
Replacement	0231 00-1
Throttle Valve (TV) Modulator	
Adust	0213 00-1
Tiedown plates	
Rear	
Replacement	0445 00-1
Tool Box Loops	
Replacement	0571 00-1
Torsion bar	
Replacement	0413 00-1
Torsion bar anchor	
Replacement	0414 00-1

INDEX, cont'd

<u>Subject</u>	<u>WP Sequence No.-Page No.</u>
Tow Pintle Extender Assembly	
M113A3	
Repair	0811 02-1
Tow Pintle Extender Kit	
M113A3	
Installation	0811 01-1
Tow Start Control Assembly	
Replacement	0391 00-1
Tow Start Control Cable Assembly	
Adjustment	0390 00-1
Tow Start Control Cover	
Replacement	0392 00-1
Towing Pintle	
Repair	0434 00-1
Replacement	0433 00-1
Track	
T130	
Replacement	0422 00-1
T150	
Replacement	0422 01-1
Track Drive Sprocket and Track Assemblies	
Reverse	0419 01-1
Track pad	
Track shoe	0424 01-1,0575 01-1
T150	
Replacement	0423 01-1
Track shoe pad	
T150	
Replacement	0424 01-1
Track shoe assembly	
Replacement	0423 00-1
Track shoe pad	
Replacement	0424 00-1
Track shoe stowage basket	0575 01-1
Track shroud and covers	
Replacement	0438 00-1
Track tension adjuster and mount	
Replacement	0419 00-1
Trailer harness	
Replacement	0375 00-1
Trailer lights don't work	0036 00-1
Trans filter clogged indicator malfunctions	0059 00-1
Trans oil hi temp indicator malfunctions	0057 00-1

INDEX, cont'd

<u>Subject</u>	<u>WP Sequence No.-Page No.</u>
Transducer	
Air box pressure	
Replacement.....	0327 00-1
Fuel return pressure	
Replacement.....	0325 00-1
Fuel supply pressure	
Replacement.....	0324 00-1
Turbo outlet pressure	
Replacement.....	0326 00-1
Transmission brake adjustment	
Check	0406 00-1
Transmission brakes	
Adjust	0394 00-1
Transmission controller wiring harness	
Replacement.....	0361 00-1
Transmission does not downshift in 1-4 position.....	0066 00-1
Transmission does not hold 1st position	0067 00-1
Transmission does not hold 2nd position	0068 00-1
Transmission does not hold 3rd position	0069 00-1
Transmission does not pivot steer	0071 00-1
Transmission does not reverse	0070 00-1
Transmission high temp indicator comes on	0072 00-1
Transmission low lube indicator comes on	0073 00-1
Transmission Mounts	
Replacement.....	0385 00-1
Transmission oil	
Cooler hoses, fittings, and mounting	
Replacement.....	0399 00-1
Level dipstick, filler tube, and adapter	
X200-4	
Replacement.....	0395 00-1
X200-4A	
Replacement.....	0396 00-1
Transmission oil and oil filter element	
Replacement.....	0398 00-1
Transmission oil drain tubes and bracket	
Replacement.....	0384 00-1
Transmission oil high temperature switch	
Replacement.....	0322 00-1
Transmission oil low pressure indicator malfunctions	0056 00-1

INDEX, cont'd

<u>Subject</u>	<u>WP Sequence No.-Page No.</u>
Transmission oil sampling valve and pressure switch	
Replacement	0400 00-1
Transmission oil supply and return hoses	
Replacement	0251 00-1
Transmission range controller lamp	
Replacement	0388 00-1
Transmission range controller switch	
Replacement	0389 00-1
Transmission range controller/bracket	
Used with solenoid-activated steering lock	
Replacement	0386 00-1
Transmission steering	
Adjust	0393 00-1
Transmission wiring harness	
Replacement	0360 00-1
Transmission won't upshift or shifts erratically in 1-4 position.....	0065 00-1
Transmitter	
Coolant temperature	
Replacement	0321 00-1
Fuel quantity	
All except M577A3 and M1068A3	
Replacement.....	0190 00-1
M577A3 and M1068A3	
Replacement.....	0191 00-1
Trim Vane	
Replacement	0458 00-1
Trim vane	
All Except M58	
Repair	0459 00-1
M58	
Repair	0460 00-1
Trim vane control linkage	
Repair	0461 00-1
Trim vane release	
Repair	0463 00-1
Replacement	0462 00-1
Tube	
Bulkhead Connection to Personnel Heater	
M577A3 and M1068A3	
Replacement.....	0687 00-1
External Cable	
Replacement	0905 00-1

INDEX, cont'd

<u>Subject</u>	<u>WP Sequence No.-Page No.</u>
Fire Extinguisher Cylinder Discharge	
Replacement.....	0899 00-1
Fire Extinguisher Turbine Cylinder Discharge	
M58	
Replacement.....	0900 00-1
From ramp control valve to bulkhead	
Replacement.....	0664 00-1
Fuel return	
M1064A3	
Replacement.....	0197 00-1
M113A3 , M1059A3, and M58	
Replacement.....	0195 00-1
M577A3 and M1068A3	
Replacement.....	0196 00-1
Fuel Vent	
M577A3 and M1068A3	
Replacement.....	0198 00-1
Personnel heater	
M577A3 and M1068A3	
Replacement.....	0700 00-1
Personnel Heater Fuel	
All Except M1064A3	
Replacement.....	0686 00-1
Thermostat	
Replacement.....	0238 00-1
Turbine access door	
M58	
Replacement.....	0485 00-1
Turbine access door gasket	
M58	
Replacement.....	0486 00-1
Turbine access door hinges	
M58	
Replacement.....	0487 00-1
Turbo outlet pressure transducer	
Replacement.....	0326 00-1
Turnbuckle parts generator	
Replacement.....	0254 00-1
U	
Unsafe ramp	
Lower	0513 00-1
Raise	0513 00-1

INDEX, cont'd

<u>Subject</u>	<u>WP Sequence No.-Page No.</u>
Upper and lower service brake pedal	
Replacement	0409 00-1
Upper Coolant Hose and Tube	
Replacement	0232 00-1
Utility outlet lead assembly	
M577A3 and M1068A3	
Replacement	0377 00-1
Utility outlet receptacle	
Replacement	0265 00-1
Utility outlet receptacles	
Rear	
M577A3 and M1068A3	
Replacement.....	0378 00-1
V	
Valve	
Front Bilge	
Replacement	0633 00-1
Fuel Shutoff	
Coolant Heater	
Replacement.....	0720 00-1
Valve Assembly	
Fuel Shut-off	
M113A3, M1059A3, and M58	
Replacement.....	0684 00-1
Variable speed drive	0359 01-1
Fan	
Replacement (Old Configuration)	0249 00-1
Replacement (New Configuration)	0249 01-1
Controller.....	0250 01-1
Fan Drive and Override Switch	
Replacement (New Configuration)	0231 01-1
Generator	
Replacement (Old Configuration)	0249 00-1
Replacement (New Configuration)	0249 01-1
Variable speed fan drive valve (Old Configuration)	0231 00-1
Override switch (New Configuration).....	0231 01-1
Vehicle batteries discharge with external AC power applied	
M1068A3 only	0103 00-1
Vehicle will not accept external AC power	
M1068A3 only	0104 00-1
Vehicle will not accept inverter AC power	
M1068A3 only	0105 00-1

INDEX, cont'd

<u>Subject</u>	<u>WP Sequence No.-Page No.</u>
Vent fitting	
Battery box	
M58	
Replacement.....	0355 00-1
Ventilating Fan Assembly	
Replacement.....	0247 00-1
Ventilating Fan Drive Belt	
Adjustment.....	0242 00-1
Replacement.....	0243 00-1
Ventilating Fan Drive Pulley	
Replacement.....	0244 00-1
Ventilation fan	
M577A3 and M1068A3	
Replacement.....	0383 00-1
VFM	
Vision Block Locks and Seals	
Driver's Hatch	
Replacement.....	0535 00-1
Vision block locks and seals	
Commander's cupola	
M1064A3	
Replacement.....	0491 00-1
M113A3 and M1059A3, M58	
Replacement.....	0490 00-1
Vision Port	
Ramp	
M58	
Replacement/Repair.....	0586 00-1
Voltage regulator	
Adjustment.....	0256 00-1
W	
W1, W2, and NATO Slave Cables	
Stowage Brackets for	
M1068A3 and M577A3	
Replacement.....	0626 01-1
Wait indicator flashes during start attempts (preglow or afterglow).....	0018 00-1
Wait indicator light doesn't light.....	0019 00-1
Warning Light Panel	
All Except M58	
Replacement.....	0292 00-1
Instrument	
Replacement.....	0288 00-1

INDEX, cont'd

<u>Subject</u>	<u>WP Sequence No.-Page No.</u>
Warning light panel Assembly	
All Except M58	
Replacement.....	0291 00-1
Warning Lights	
Instrument Panel	
Replacement.....	0287 00-1
Warning Panel Lights	
M58	
Replacement.....	0294 01-1
Warning panel lights	
All Except M58	
Replacement.....	0294 00-1
Warning panel wiring harness	
Replacement.....	0374 00-1
Water barrier	
M113A3, M577A3, and M1068A3 only	
Replacement.....	0456 00-1
Water barrier loop and strap	
M113A3, M577A3, and M1068A3 only	
Replacement.....	0457 00-1
Water/Ration Heater	
Mount Bracket	
(M113A3 Only)	
Replace.....	0811 00-1
Power Cable	
(M113A3 Only)	
Replace.....	0810 00-1
Webbing straps	
Replacement.....	0569 00-1
Wheel	
Idler	
Replacement.....	0425 00-1
Road	
Replacement.....	0426 00-1
Windshield	
Driver's	
Replacement.....	0739 00-1
Stowage bag, straps, and decal	
Replacement.....	0740 00-1
Stowage Bracket	
M1064A3	
Replacement.....	0614 00-1

INDEX, cont'd

<u>Subject</u>	<u>WP Sequence No.-Page No.</u>
Wire harness	
Radiac	
M113A3, M577A3, and M1068A3	
Replacement.....	0376 00-1
Wire Rope and Pulleys	
M1064A3	
Replacement.....	0658 00-1
Wire rope and pulleys	
All Except M1064A3	
Replacement.....	0657 00-1
Wiring Harness	
Air Box Heater	
Replacement.....	0205 00-1
Coolant Heater	
Replacement.....	0735 00-1
Coolant Pump to Heater	
Replacement.....	0733 00-1
M13 NBC Heater	
(M577A3)	
Replace.....	0808 00-1
M14 NBC Heater	
(M113A3 Ambulance)	
Replace.....	0807 00-1
M3 NBC Heater (M1059A3)	
Replace.....	0806 00-1
Repair	0382 00-1
STE/ICE Crew	
M1064A3	
Replacement.....	0881 00-1
STE/ICE Crew, M113A3 and M1059A3	
Replacement.....	0878 00-1
STE/ICE Crew, M577A3 and M1068A3	
Replacement.....	0879 00-1
STE/ICE Engine	
Replacement.....	0882 00-1
Wiring harness	
3W1	0359 01-1
Battery-to-radio (Left Side)	
M113A3 and M1059A3	
Replacement.....	0369 00-1
Engine	
Replacement.....	0359 00-1

INDEX, cont'd

<u>Subject</u>	<u>WP Sequence No.-Page No.</u>
Instrument panel battery-generator gauge	
Replace.....	0289 00-1
M13 NBC Heater	
M1068A3 only	
Replace.....	0809 00-1
M577A3	
Replace.....	0803 00-1
■ Rear main	
M1064A3	
Replacement.....	0364 00-1
M1068A3	
Replacement.....	0365 00-1
■ M113A3, M1059A3, and M58	
Replacement.....	0362 00-1
M577A3	
Replacement.....	0363 00-1
Right headlight	
Replace.....	0373 00-1
Smoke grenade launcher	
■ M113A3, M1059A3, and M58	
Replacement.....	0366 00-1
Steering lock switch	
All Except M58	
Replacement.....	0367 00-1
M58	
Replacement.....	0367 01-1
Transmission	
Replacement.....	0360 00-1
Transmission controller	
Replacement.....	0361 00-1
Warning panel	
Replacement.....	0374 00-1
Wiring harness (right side)	
Battery-to-radio	
M113A3	
Replacement.....	0370 00-1
Wiring Harnesses, Cables, Leads	
Chemical Alarm Interface	
M113A3	
Replacement.....	0923 00-1
Circuit 44A, Power Control Enclosure Leads	
M1068A3	
Replacement.....	0829 00-1

INDEX, cont'd

Subject

WP Sequence No.-Page No.

Wiring Harnesses, cables, leads

W251

M1068A3

Replacement..... 0852 00-1

W42

M1068A3

Replacement..... 0852 00-1

W43

M1068A3

Replacement..... 0852 00-1

Wiring harnesses, cables, leads

W124

M1068A3

Replacement..... 0855 00-1

Wiring Harnesses, cables, leads:

LAN A or B (W103/W104)

M1068A3

Replacement..... 0854 00-1

W45

M1068A3

Replacement..... 0853 00-1

Wiring harnesses, cables, leads:

W126

M1068A3

Replacement..... 0856 00-1

By Order of the Secretary of the Army:

Official:



JOEL B. HUDSON

*Administrative Assistant to the
Secretary of the Army*

9913203

ERIC K. SHINSEKI
*General, United States Army
Chief of Staff*

DISTRIBUTION: To be distributed in accordance with the initial distribution requirements for IDN: 371205, requirements for TM 9-2350-277-20-2.

RECOMMENDED CHANGES TO PUBLICATIONS AND BLANK FORMS	Use Part II (<i>reverse</i>) for Repair Parts and Special Tools Lists (RPSTL) and Supply Catalogs/Supply Manuals (SC/SM).	Date 23 JUL 01
For use of this form, see AR 25-30; the proponent agency is ODISC4.		
TO: (<i>Forward to proponent of publication or form</i>) (<i>Include ZIP Code</i>)		FROM: (<i>Activity and location</i>) (<i>include ZIP code</i>) COMMANDER COMPANY A, 216 CAV FORT KNOX, KY 40121

PART I - ALL PUBLICATIONS (EXCEPT RPSTL AND SC/SM) AND BLANK FORMS

PUBLICATION/FORM NUMBER TM 9-2350-277-20-2	DATE 02 JAN 01	TITLE Unit Maintenance Manual for M113A3 FOV
---	-------------------	---

ITEM	PAGE	PARA	LINE	FIGURE NO.	TABLE	RECOMMENDED CHANGES AND REASON
	0014 00-2					STEP b. THE SCREWS (4) ON BRACKET (2) MUST BE TORQUED PLEASE ADD TORQUE INFORMATION.
	0023 00-34			5 (SH15)		THERE ARE FOUR CLAMPS (144) ON WIRING HARNESS (217), NOT THREE AS SHOWN. PLEASE CORRECT

*Reference to line numbers within the paragraph or subparagraph.

TYPED NAME, GRADE OR TITLE	TELEPHONE EXCHANGE/AUTOVON, PLUS EXTENSION	SIGNATURE

TO: <i>(Forward direct to addressee listed in publication)</i>	FROM: <i>(Activity and location) (Include Zip Code)</i>	DATE
--	---	------

PART II - REPAIR PARTS AND SPECIAL TOOL LISTS AND SUPPLY CATALOGS/SUPPLY MANUALS

PUBLICATION NUMBER			DATE			TITLE		
PAGE NO.	COLM NO.	LINE NO.	NATIONAL STOCK NUMBER	REFERENCE NO.	FIGURE NO.	ITEM NO.	TOTAL NO. OF MAJOR ITEMS SUPPORTED	RECOMMENDED ACTION

PART III - REMARKS *(Any general remarks or recommendations, or suggestions for improvement of publications and blank forms. Additional blank sheets may be used if more space is needed.)*

SAMPLE

TYPED NAME, GRADE OR TITLE	TELEPHONE EXCHANGE/AUTOVON, PLUS EXTENSION	SIGNATURE
----------------------------	--	-----------

RECOMMENDED CHANGES TO PUBLICATIONS AND BLANK FORMS

For use of this form, see AR 25-30: the proponent agency is ODISC4.

Use Part II (*reverse*) for Repair Parts and Special Tools Lists (RPSTL) and Supply Catalogs/Supply Manuals (SC/SM).

Date

TO: (*Forward to proponent of publication or form*) (*Include ZIP Code*)

FROM: (*Activity and location*) (*include ZIP code*)

PART I – ALL PUBLICATIONS (EXCEPT RPSTL AND SC/SM) AND BLANK FORMS

PUBLICATION/FORM NUMBER
TM 9-2350-277-20-2

DATE
02 JAN 01

TITLE
Unit Maintenance Manual for M113A3 FOV

ITEM	PAGE	PARA	LINE	FIGURE NO.	TABLE	RECOMMENDED CHANGES AND REASON

**Reference to line numbers within the paragraph or subparagraph.*

TYPED, GRADE OR TITLE

TELEPHONE EXCHANGE/AUTOVON, PLUS EXTENSION

SIGNATURE

TO: <i>(Forward direct to addressee listed in publication)</i>	FROM: <i>(Activity and location) (Include Zip Code)</i>	DATE
--	---	------

PART II - REPAIR PARTS AND SPECIAL TOOL LISTS AND SUPPLY CATALOGS/SUPPLY MANUALS

PUBLICATION NUMBER			DATE			TITLE		
PAGE NO.	COLM NO.	LINE NO.	NATIONAL STOCK NUMBER	REFERENCE NO.	FIGURE NO.	ITEM NO.	TOTAL NO. OF MAJOR ITEMS SUPPORTED	RECOMMENDED ACTION

PART III - REMARKS *(Any general remarks or recommendations, or suggestions for improvement of publications and blank forms. Additional blank sheets may be used if more space is needed.)*

--

TYPED NAME, GRADE OR TITLE	TELEPHONE EXCHANGE/AUTOVON, PLUS EXTENSION	SIGNATURE
----------------------------	--	-----------

RECOMMENDED CHANGES TO PUBLICATIONS AND BLANK FORMS

For use of this form, see AR 25-30: the proponent agency is ODISC4.

Use Part II (*reverse*) for Repair Parts and Special Tools Lists (RPSTL) and Supply Catalogs/Supply Manuals (SC/SM).

Date

TO: (*Forward to proponent of publication or form*) (*Include ZIP Code*)

FROM: (*Activity and location*) (*include ZIP code*)

PART I – ALL PUBLICATIONS (EXCEPT RPSTL AND SC/SM) AND BLANK FORMS

PUBLICATION/FORM NUMBER
TM 9-2350-277-20-2

DATE
02 JAN 01

TITLE
Unit Maintenance Manual for M113A3 FOV

ITEM	PAGE	PARA	LINE	FIGURE NO.	TABLE	RECOMMENDED CHANGES AND REASON

**Reference to line numbers within the paragraph or subparagraph.*

TYPED, GRADE OR TITLE

TELEPHONE EXCHANGE/AUTOVON, PLUS EXTENSION

SIGNATURE

TO: <i>(Forward direct to addressee listed in publication)</i>	FROM: <i>(Activity and location) (Include Zip Code)</i>	DATE
--	---	------

PART II - REPAIR PARTS AND SPECIAL TOOL LISTS AND SUPPLY CATALOGS/SUPPLY MANUALS

PUBLICATION NUMBER			DATE			TITLE		
PAGE NO.	COLM NO.	LINE NO.	NATIONAL STOCK NUMBER	REFERENCE NO.	FIGURE NO.	ITEM NO.	TOTAL NO. OF MAJOR ITEMS SUPPORTED	RECOMMENDED ACTION

PART III - REMARKS *(Any general remarks or recommendations, or suggestions for improvement of publications and blank forms. Additional blank sheets may be used if more space is needed.)*

--

TYPED NAME, GRADE OR TITLE	TELEPHONE EXCHANGE/AUTOVON, PLUS EXTENSION	SIGNATURE
----------------------------	--	-----------

THE METRIC SYSTEM AND EQUIVALENTS

LINEAR MEASURE

1 Centimeter = 10 Millimeters = 0.01 Meters = 0.3937 Inches
 1 Meter = 100 Centimeters = 1000 Millimeters = 39.37 Inches
 1 Kilometer = 1000 Meters = 0.621 Miles

WEIGHTS

1 Gram = 0.001 Kilograms = 1000 Milligrams = 0.035 Ounces
 1 Kilogram = 1000 Grams = 2.2 Lb.
 1 Metric Ton = 1000 Kilograms = 1 Megagram = 1.1 Short Tons

LIQUID MEASURE

1 Milliliter = 0.001 Liters = 0.0338 Fluid Ounces
 1 Liter = 1000 Milliliters = 33.82 Fluid Ounces

SQUARE MEASURE

1 Sq. Centimeter = 100 Sq. Millimeters = 0.155 Sq. Inches
 1 Sq. Meter = 10,000 Sq. Centimeters = 10.76 Sq. Feet
 1 Sq. Kilometer = 1,000 Sq. Meters = 0.386 Sq. Miles

CUBIC MEASURE

1 Cu. Centimeter = 1000 Cu. Millimeters = 0.06 Cu. Inches
 1 Cu. Meter = 1,000,000 Cu. Centimeters = 35.31 Cu. Feet

TEMPERATURE

$5/9 (^{\circ}\text{F} - 32) = ^{\circ}\text{C}$
 212° Fahrenheit is equivalent to 100° Celsius
 90° Fahrenheit is equivalent to 32.2° Celsius
 32° Fahrenheit is equivalent to 0° Celsius
 $(9/5 \times ^{\circ}\text{C}) + 32 = ^{\circ}\text{F}$

TO CHANGE	TO	MULTIPLY BY
Inches	Centimeters	2.540
Feet	Meters	0.305
Yards	Meters	0.914
Miles	Kilometers	1.609
Square Inches	Square Centimeters	6.451
Square Feet	Square Meters	0.093
Square Yards	Square Meters	0.836
Square Miles	Square Kilometers	2.590
Acres	Square Hectometers	0.405
Cubic Feet	Cubic Meters	0.028
Cubic Yards	Cubic Meters	0.765
Fluid Ounces	Millimeters	29.573
Pints	Liters	0.473
Quarts	Liters	0.946
Gallons	Liters	3.785
Ounces	Grams	28.349
Pounds	Kilograms	0.454
Short Tons	Metric Tons	0.907
Pound-Feet	Newton-Meters	1.356
Pounds per Square Inch	Kilopascals	6.895
Miles per Gallon	Kilometers per Liter	0.425
Miles per Hour	Kilometers per Hour	1.609

TO CHANGE	TO	MULTIPLY BY
Centimeters	Inches	0.394
Meters	Feet	3.280
Meters	Yards	1.094
Kilometers	Miles	0.621
Square Centimeters	Square Inches	0.155
Square Meters	Square Feet	10.764
Square Meters	Square Yards	1.196
Square Kilometers	Square Miles	0.386
Square Hectometers	Acres	2.471
Cubic Meters	Cubic Feet	35.315
Cubic Meters	Cubic Yards	1.308
Milliliters	Fluid Ounces	0.034
Liters	Pints	2.113
Liters	Quarts	1.057
Liters	Gallons	0.264
Grams	Ounces	0.035
Kilograms	Pounds	2.205
Metric Tons	Short Tons	1.102
Newton-Meters	Pound-Feet	0.738
Kilopascals	Pounds per Square Inch	0.145
Kilometers per Liter	Miles per Gallon	2.354
Kilometers per Hour	Miles per Hour	0.621

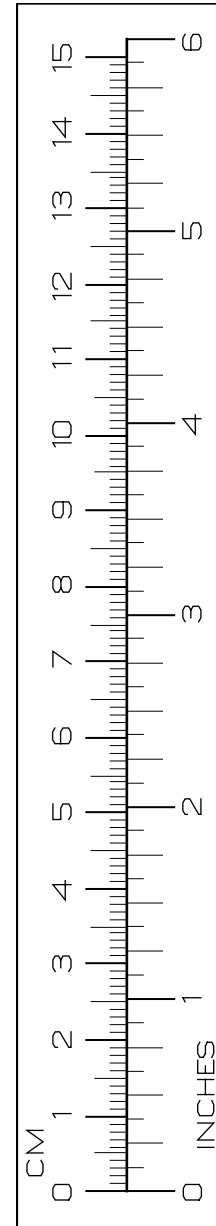

PIN: 062443-000